

MX21 INSTA-MOUNT™ Series—Modular Incremental Rotary Optical Encoder

BEI Sensors



By the time you have read this first sentence, you could have installed BEI's model MX21 INSTA-MOUNT™ modular optical encoder. In addition to its quick and easy installation, the MX21 is designed to operate with jitter-free output signals without tight controls on shaft endplay, runout, or perpendicularity. The new INSTA-MOUNT™ encoder is capable of operating within a temperature range of -10° to +70°C, requiring less than 30 milliamps of L.E.D. current, without degradation of output signals and is short circuit protected.

The MX21 is perfectly suited for motor manufacturers and other high volume OEMs. BEI's INSTA-MOUNT™ Series encoder offers 5V TTL compatible quadrature outputs with index and complements as options. Axial shaft movements during operation, of ± 0.010 " will not adversely affect the output signals. Shaft runouts of 0.005" TIR can also be absorbed by this device without affecting output signal performance.

Mechanical Specifications

Dimensions: See Figure 1
Weight: 2.1 oz. (Approx.)
Moment of Inertia: 2.6×10^{-5} oz in sec²
Bore Size: see "Ordering Options"

Motor Interface

Mount Holes: #4-40 or M3 x 0.5 @ 180° on 1.812" dia. B.C.
Mount Hardware: 2 sockethead cap screws
Perpendicularity Shaft to Mount: 0.002" TIR
Shaft Runout: 0.005" max (each 0.0001 degrades accuracy by 0.5 arc minutes)
Shaft Endplay Dynamic or Static: ± 0.010 "
Shaft Finish: 16 micro inches or better. End must be chamfered or rounded
Shaft Tolerance: nominal -0.0002"/-0.0007"
Shaft Length: 0.56" minimum remove (remove cover button for motor through-shafts)

Electrical Specifications

Code: Incremental
Pulses per revolutions (PPR): See "Ordering Options")
Index Pulse Options un gated index (U)
 gated index (G)
Supply Voltage: 5 volts $\pm 5\%$ @ 80mA max.
Output Format: dual channel quadrature & index (MX212 & 213) (no index on MX212)
 (MX216) dual channel quad & index w/ comps
Output Type:
 (MX212 & 213): square wave TTL. 16mA sink
 500ΩA source. Short circuit protected
 (MX216): TTL differential line driver (26LS31 or equiv.) should be terminated into a line receiver (26LS32, or equivalent circuit)
Frequency Response: see graph: Fig 3
Rise Time: 1.0μ sec. max.

Environmental Specifications

Temperature:
 Operating: -10°C to +70°C
 Storage: -40°C to +125°C

Termination Specifications

Ribbon: 28 AWG flat ribbon cable with 10 position connector Berg P/N 65863-165 or equiv. Mates with Berg P/N65863-165 or equiv) (mating connector not provided)
Round Cable: 28AWG 8 Conductor shielded cable

*NOTE: See pinout tables, back page.

MX21 Series Encoder Ordering Options: for assistance, call 800.350.2727
 Use this diagram, working from left to right to construct your model number (example: MX213-38-512-G-R18)

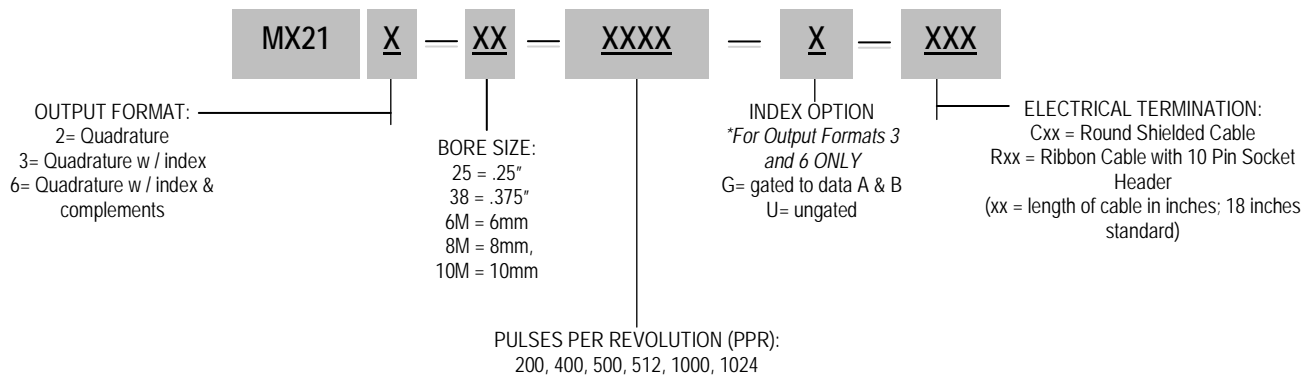

MX21 INSTA-MOUNT™ Series—Modular Incremental Rotary Optical Encoder

BEI Sensors

Dimensions

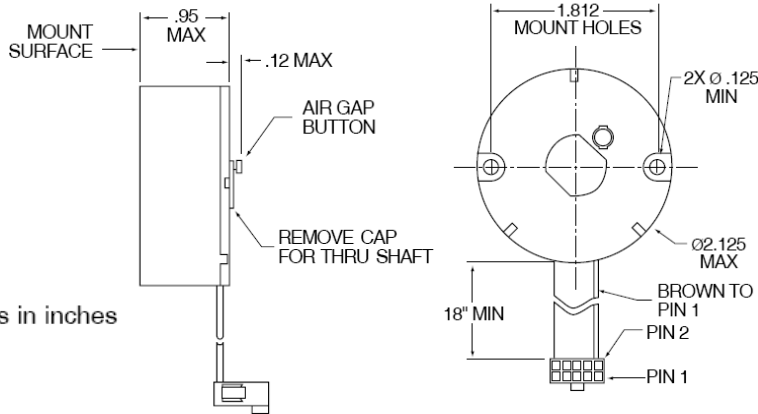

All dimensions in inches

.xx = ±.02
.xxx = ±.005

Installation

Instructions

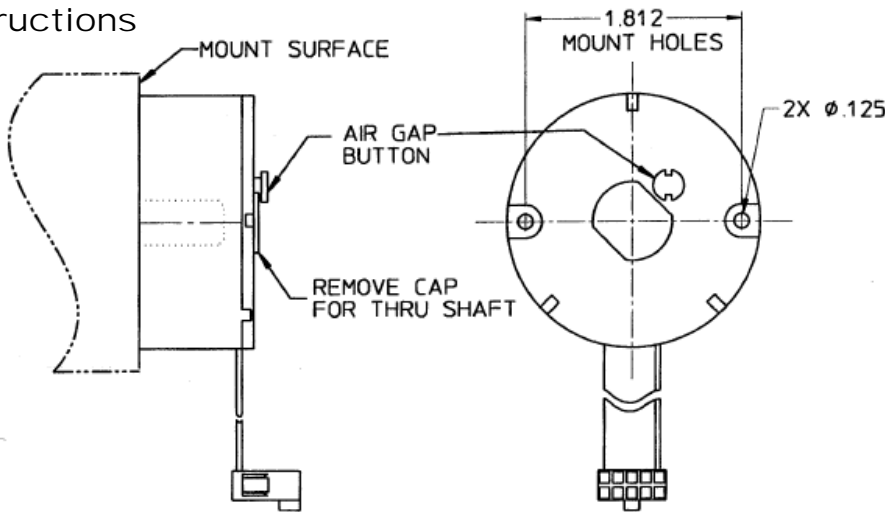

Preparation:

1. Inspect motor interface per MX21 Data Sheet or specification drawing.
2. Motor shaft must be free of burrs & other surface defects.

Installation:

1. Motor shaft should NOT be rotating during initial encoder installation.
2. Hold encoder perpendicular to motor shaft. Guide the encoder onto the motor shaft, pushing encoder STRAIGHT on until it is flush against the mount surface. Do NOT rock side to side.
3. Install two #4-40 mount screws. Do not fully tighten at this point. (Note: A thread sealant should be applied to the screw threads)
4. Rotate the motor shaft (300 RPM, minimum). Press the air-gap button until it bottoms to the top of the encoder momentarily, then release. CAUTION: DO NOT press air-gap button while motor shaft is stationary. Button should only be pressed for one or two seconds while shaft is rotating.
5. Tighten mounting screws fully. (recommended torque is 30 to 40 ounce inches.)
6. This completes the mechanical installation. Proceed with electrical connections as indicated on product data sheet or specification drawing.

Removal:

1. Motor shaft may be stationary or rotating up to 1000 RPM during encoder removal.
2. Remove two mounting screws.
3. Grasp encoder firmly and pull STRAIGHT off of the motor shaft. Do NOT rock side to side.

These commodities, technology or software if exported from the United States must be in accordance with the Bureau of Industry, and Security, Export Administration regulations. Diversion contrary to U.S law is prohibited.

Output

Waveform

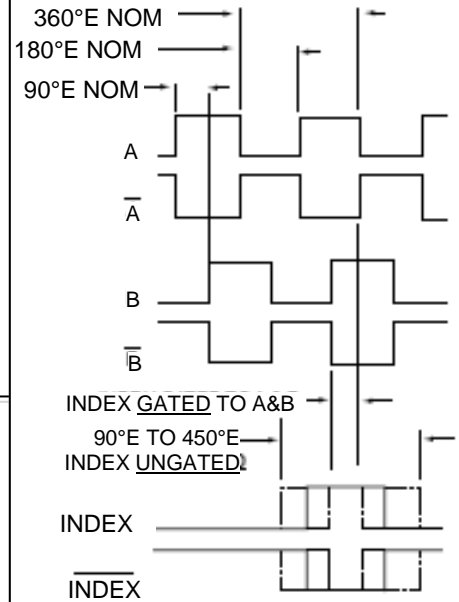

→ CCW ROTATION OF SHAFT →
MX212 outputs A & B ONLY
MX213 outputs A, B & INDEX ONLY
MX216 outputs as shown

Figure 3

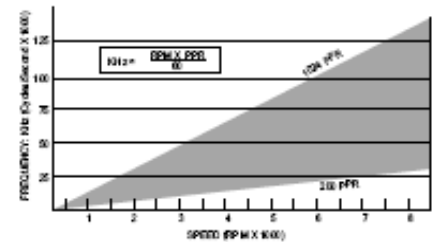

Terminations

Pinout MX212/213

Pin #	Signal	Pin #	Signal
1	channel A	6	NC
2	+5 volts	7	NC
3	ground	8	channel B
4	NC	9	NC
5	NC	10	index (213)

Pinout MX216

Pin #	Signal	Pin #	Signal
1	NC	6	channel A
2	+5 volts	7	channel B
3	ground	8	channel B
4	NC	9	index
5	channel A	10	index