

Features

- Full Bridge Gate Driver
- Internal High Voltage Level Shift Function
- Negative 550V Lamp Supply Voltage
- 3V to 12V CMOS Logic Compatible
- 8V to 12V Input Supply Voltage
- No External Bootstrap Capacitors Needed

Applications

- Commutator for High Intensity Discharge Lamps
- Vehicle Head Lamps
- Outdoor/Street Lighting
- Multimedia Projectors
- Retail Accent Lighting
- Warehouse Lighting

Description

Built on IXYS Integrated Circuits Division's high voltage integrated circuit (HVIC) technology, the MX6895 combines high-side and low-side N-channel power MOSFET drivers in a full bridge configuration. The circuit is optimally configured to be used as a commutator for High Intensity Discharge (HID) lamps.

Ordering Information

Part	Description
MX6895BE	SOIC-16 Tube (49/Tube)
MX6895BETR	SOIC-16 Tape & Reel (2500/Reel)



Functional Block Diagram and Typical Application Circuit

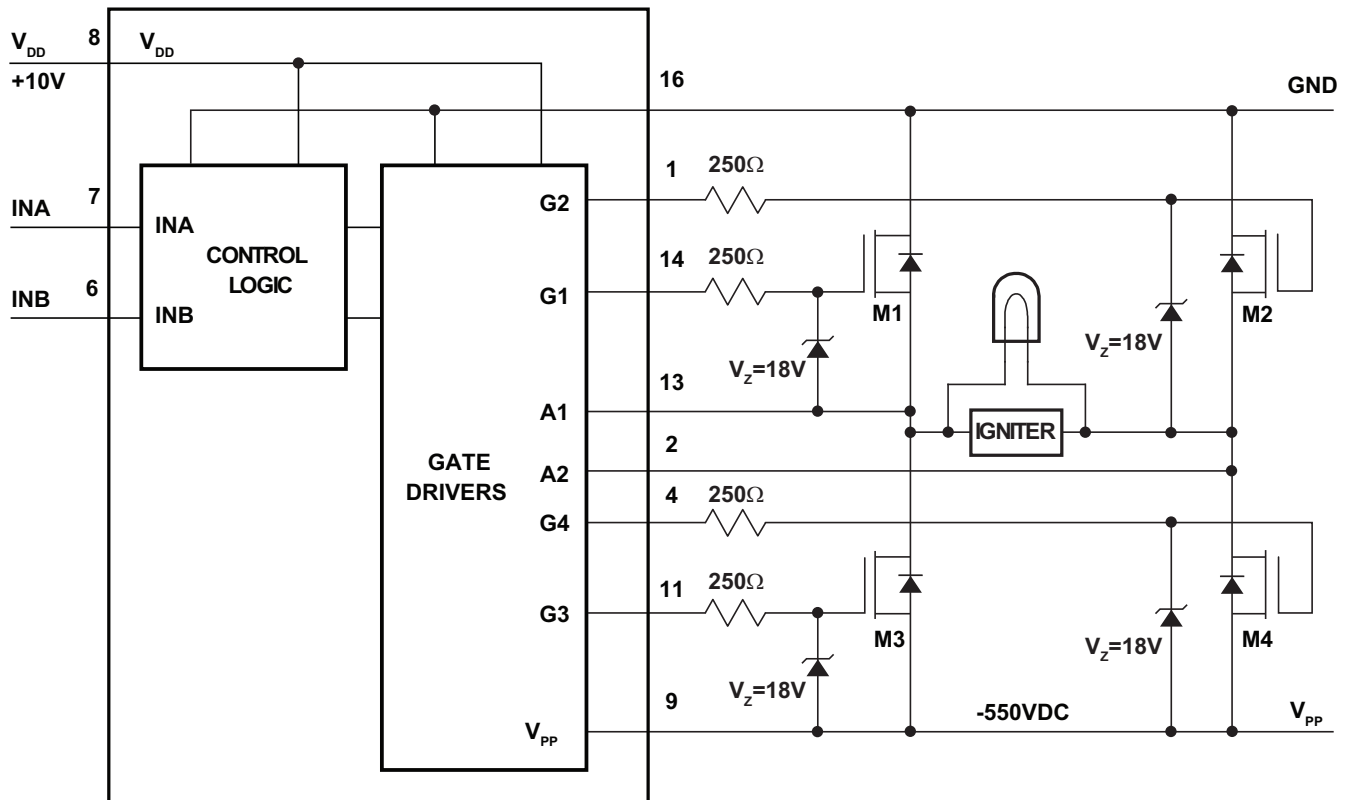

1. Specifications	3
1.1 Package Pinout	3
1.2 Pin Description	3
1.3 Absolute Maximum Ratings	3
1.4 Thermal Characteristics	4
1.5 Recommended Operating Conditions	4
1.6 DC Electrical Characteristics	4
1.7 AC Electrical Characteristics	5
2. Functional Block Diagram and Truth Table	6
3. Input / Output Switching Waveforms	7
4. Manufacturing Information	8
4.1 Moisture Sensitivity	8
4.2 ESD Sensitivity	8
4.3 Reflow Profile	8
4.4 Mechanical Dimensions	9

1 Specifications

1.1 Package Pinout

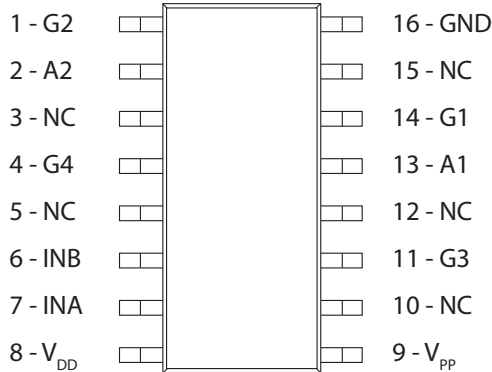

ESD Warning: ESD (electrostatic discharge) sensitive device. Although the MX6895 features proprietary ESD protection circuitry, permanent damage may be sustained if it is subjected to high energy electrostatic discharges. Proper ESD precautions are recommended to avoid performance degradation or loss of functionality.

Note: The exposed thermal pad of the device package must be connected to GND (ground).

1.2 Pin Description

Pin#	Name	Description
1	G2	High-Side Gate Driver 2 Output
2	A2	High-Side Gate Driver 2 Floating DC Power Return
3	NC	No Connection
4	G4	Low-Side Gate Driver 4 Output
5	NC	No Connection
6	INB	Control Input for High-Side Driver 2 and Low-Side Driver 3
7	INA	Control Input for High-Side Driver 1 and Low-Side Driver 4
8	V _{DD}	Logic Power Supply
9	V _{PP}	High-Voltage Negative Lamp Supply
10	NC	No Connection
11	G3	Low-Side Gate Driver 3 Output
12	NC	No Connection
13	A1	High-Side Gate Driver 1 Floating DC Power Return
14	G1	High-Side Gate Driver 1 Output
15	NC	No Connection
16	GND	Ground

1.3 Absolute Maximum Ratings

Parameter	Symbol	Min	Typ	Max	Units
Power Supply Voltage Range	V _{DD}	-0.3	-	15	V
Lamp Supply Voltage, Max	V _{PP}	-	-	-550	V
Input Voltage	V _{INA} , V _{INB}	-0.3	-	V _{DD} +0.3	V
Gate Driver Output Voltage	V _{G1} -V _{A1} V _{G2} -V _{A2} V _{G3} -V _{PP} V _{G4} -V _{PP}	-0.3	-	20	V
Power Dissipation	P _D	-	-	2.9	W
Operating Junction Temperature	T _J	-	-	150	°C
Input Capacitance of External Power Transistors	C _{ISS(LOAD)}	0.4	-	1.5	nF
Storage Temperature	T _{STG}	-50	-	150	°C

Absolute maximum electrical ratings are at 25°C.

Voltages with respect to GND=0V.

Absolute maximum ratings are stress ratings. Stresses in excess of these ratings can cause permanent damage to the device. Functional operation of the device at conditions beyond those indicated in the operational sections of this data sheet is not implied.

1.4 Thermal Characteristics

Parameter	Symbol	Minimum	Typical	Maximum	Unit
Thermal Resistance, Junction-to-Ambient ¹	$R_{\theta JA}$	-	42	-	°C/W

¹ 4-layer PCB

1.5 Recommended Operating Conditions

Parameter	Symbol	Min	Typ	Max	Units
Power Supply Voltage	V_{DD}	8	10	12	V
Lamp Supply Voltage	V_{PP}	-50	-	-550	V
Logic Input Voltage, High	V_{INAH}, V_{INBH}	2.5	V_{DD}	V_{DD}	V
Logic Input Voltage, Low	V_{INAL}, V_{INBL}	0	0	0.5	V
Ambient Temperature	T_A	-40	-	105	°C

1.6 DC Electrical Characteristics

Parameter	Conditions	Symbol	Min	Typ	Max	Units
Power Supply Current	$V_{DD}=10V, V_{PP}=-85V, V_{INA}=V_{DD}, V_{INB}=V_{DD}$	I_{DD}	-	1	2	mA
Power Supply Current	$V_{DD}=10V, V_{PP}=-85V, V_{INA}=V_{DD}, V_{INB}=V_{DD}$	I_{PP}	-	0.8	2	mA
Power Supply Current	$V_{DD}=10V, V_{PP}=-85V, V_{INA}=2.5V, V_{INB}=2.5V$	I_{DD}	-	1.5	4	mA
High Input Current	$V_{INAH}=10V, V_{INBH}=10V$	I_{INAH}, I_{INBH}	-	-	10	μA
Low Input Current	$V_{INAL}=0V, V_{INBL}=0V$	I_{INAL}, I_{INBL}	-	-	10	μA
High-Side Gate Driver Output Voltage	$V_{DD}=8V, V_{PP}=-85V, V_{A1}=V_{A2}=0V$	$(V_{G1}-V_{A1}), (V_{G2}-V_{A2})$	7	-	8	V
High-Side Gate Driver Output Voltage	$V_{DD}=10V, V_{PP}=-85V, V_{A1}=V_{A2}=0V$	$(V_{G1}-V_{A1}), (V_{G2}-V_{A2})$	9	-	10	V
Low-Side Gate Driver Output Voltage	$V_{DD}=8V \text{ to } 10V, V_{PP}=-85V$	$(V_{G3}-V_{PP}), (V_{G4}-V_{PP})$	7	16	18	V
High-Side Gate Driver Output Source Current	$V_{DD}=10V, V_{PP}=-85V, V_{A1}=V_{A2}=0V, V_{G1}-V_{A1}=0V, V_{G2}-V_{A2}=0V$	(I_{G1}, I_{G2})	-	-3.9	-	mA
Low-Side Gate Driver Output Source Current	$V_{DD}=8V \text{ to } 10V, V_{PP}=-85V, V_{G3}-V_{PP}=0V, V_{G4}-V_{PP}=0V$	(I_{G3}, I_{G4})	-	-14	-	mA

1.7 AC Electrical Characteristics

Test Conditions: $V_{DD}=10V$, $V_{PP}=-85V$, $V_{A1}=V_{A2}=0V$, $T_A=25^\circ$ unless otherwise specified.

Parameter	Conditions	Symbol	Minimum	Typical	Maximum	Units
Operating Frequency	-	f_{OP}	-	0.5	-	kHz
High-Side ON Time @ $V_{OUT}=5V$	$C_{LOAD}=1nF, R_S=0\Omega$	t_{ONH}	-	3.48	-	μs
	$C_{LOAD}=1nF, R_S=250\Omega$		-	3.77	-	
High-Side OFF Time @ $V_{OUT}=2V$	$C_{LOAD}=1nF, R_S=0\Omega$	t_{OFFH}	-	0.31	-	μs
	$C_{LOAD}=1nF, R_S=250\Omega$		-	0.66	-	
Low-Side ON Time @ $V_{OUT}=5V$	$C_{LOAD}=1nF, R_S=0\Omega$	t_{ONL}	-	2.46	-	μs
	$C_{LOAD}=1nF, R_S=250\Omega$		-	2.44	-	
Low-Side OFF Time @ $V_{OUT}=2V$	$C_{LOAD}=1nF, R_S=0\Omega$	t_{OFFL}	-	0.29	-	μs
	$C_{LOAD}=1nF, R_S=250\Omega$		-	0.76	-	

- Notes: 1. V_{OUT} is the voltage on C_{LOAD} at the defined time.
 2. $V_{OUT} = V_{G1}-V_{A1}$, or $V_{OUT} = V_{G2}-V_{A2}$, or $V_{OUT} = V_{G3}-V_{PP}$, or $V_{OUT} = V_{G4}-V_{PP}$

Figure 1. AC Test Circuit

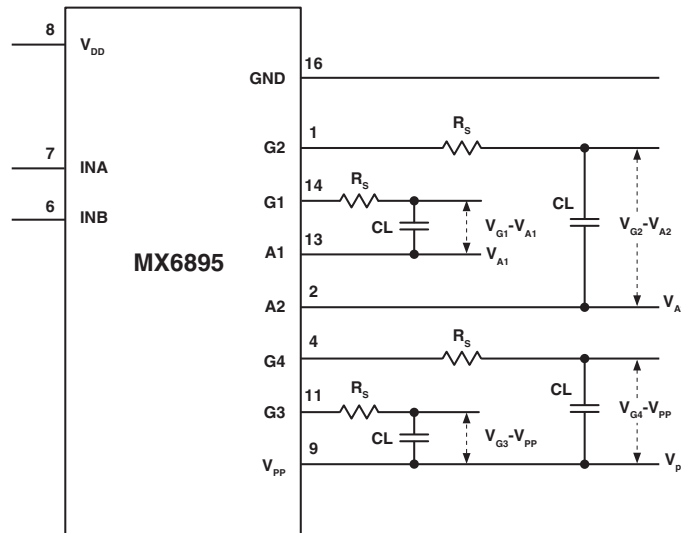
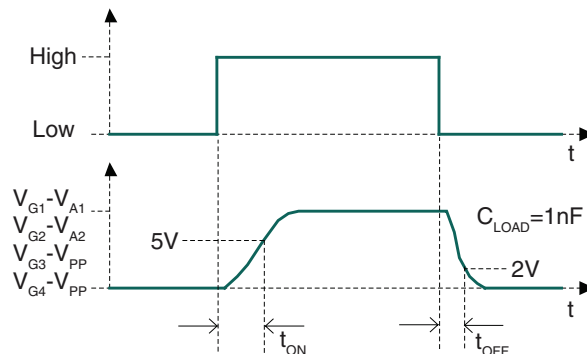
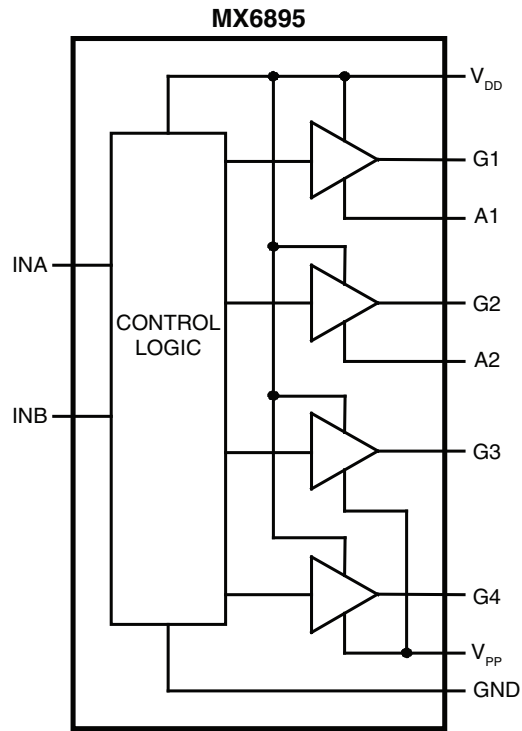

Figure 2. AC Switching Waveforms



2 Functional Block Diagram and Truth Table



INA	INB	G1 - A1	G2 - A2	G3 - V _{pp}	G4 - V _{pp}
LOW	LOW	LOW	LOW	LOW	LOW
HIGH	LOW	HIGH	LOW	LOW	HIGH
LOW	HIGH	LOW	HIGH	HIGH	LOW
HIGH	HIGH	LOW	LOW	LOW	LOW

3 Input / Output Switching Waveforms

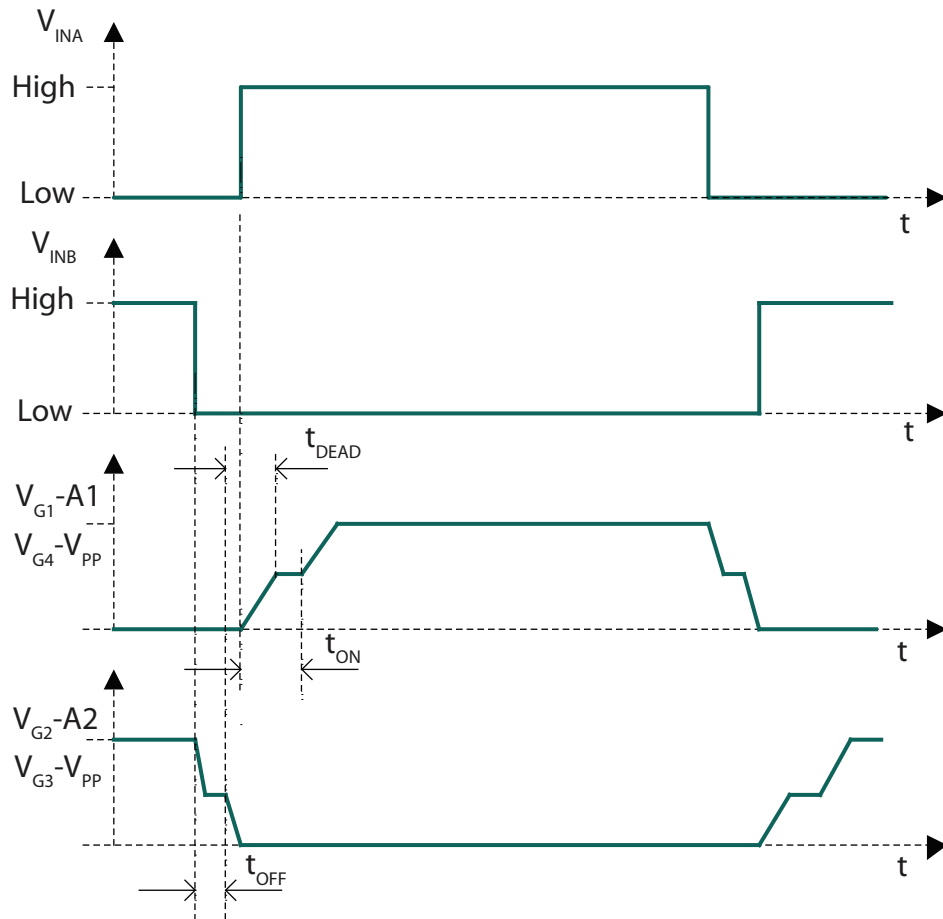

4 Manufacturing Information

4.1 Moisture Sensitivity



All plastic encapsulated semiconductor packages are susceptible to moisture ingress. IXYS Integrated Circuits Division classified all of its plastic encapsulated devices for moisture sensitivity according to the latest version of the joint industry standard, **IPC/JEDEC J-STD-020**, in force at the time of product evaluation. We test all of our products to the maximum conditions set forth in the standard, and guarantee proper operation of our devices when handled according to the limitations and information in that standard as well as to any limitations set forth in the information or standards referenced below.

Failure to adhere to the warnings or limitations as established by the listed specifications could result in reduced product performance, reduction of operable life, and/or reduction of overall reliability.

This product carries a **Moisture Sensitivity Level (MSL) rating** as shown below, and should be handled according to the requirements of the latest version of the joint industry standard **IPC/JEDEC J-STD-033**.

Device	Moisture Sensitivity Level (MSL) Rating
MX6895BE	MSL 1

4.2 ESD Sensitivity



This product is **ESD Sensitive**, and should be handled according to the industry standard **JESD-625**.

4.3 Reflow Profile

This product has a maximum body temperature and time rating as shown below. All other guidelines of **J-STD-020** must be observed.

Device	Maximum Temperature x Time
MX6895BE	260°C for 30 seconds

