

Automotive Grade

MXR7150VW

FEATURES

- Dual axis accelerometer fabricated on a single CMOS IC
- Monolithic design with mixed mode signal processing
- Zero-g temperature stability better than ± 300 mg from -40°C to 125°C
- Sensitivity temperature compensation better than $\pm 10\%$ from -40°C to 125°C
- $\pm 13.3\text{g}$ dynamic range, 150mV/g sensitivity
- 29Hz bandwidth
- On Demand Self Test
- $>50,000$ g shock survival rating
- 4.75V to 5.25V single supply operation
- Small surface mount package, $5.5\text{mm} \times 5.5\text{mm} \times 2.7\text{mm}$
- XZ mounting
- RoHS compliant
- AEC-Q100 class 1

AUTOMOTIVE APPLICATIONS

- Active Suspension Control
- Roll Over Detection

GENERAL DESCRIPTION

The MXR7150VW is a low cost, dual axis accelerometer built on a standard, submicron CMOS process. It measures acceleration with a full-scale range of -13.3g to $+13.3\text{g}$ and a sensitivity of 150mV/g .

The MXR7150VW provides a g-proportional rationmetric analog output above/ below the zero-g point at 50% of the supply voltage.

The typical noise floor is 8 mg. The inherent 3dB roll off of the device is 29Hz providing immunity to and attenuation of higher frequency vibrations present in automotive applications.

The MXR7150VW is packaged in a hermetically sealed LCC surface mount package (5.5 mm \times 5.5 mm \times 2.7 mm height), and the package can be used for XZ sensing, its operation temperature is -40°C to $+125^{\circ}\text{C}$. It can measure both dynamic acceleration (e.g., vibration) and static acceleration (e.g., gravity).

Information furnished by MEMSIC is believed to be accurate and reliable. However, no responsibility is assumed by MEMSIC for its use, nor for any infringements of patents or other rights of third parties, which may result from its use. No license is granted by implication or otherwise under any patent or patent rights of MEMSIC.

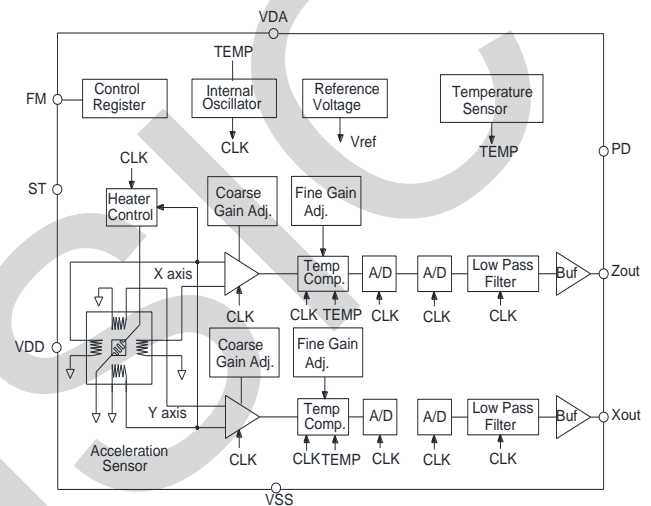

MXR7150VW FUNCTIONAL BLOCK DIAGRAM

The design is based on heat convection and requires no solid proof mass. This eliminates stiction, particle, and inherent resonant frequency problems associated with competitive devices and provides shock survivability to greater than $50,000\text{g}$, leading to significantly lower failure rates and lower loss due to handling during assembly and at customer field application.

Due to the standard CMOS structure of the MXR7150VW, additional circuitry can easily be incorporated into custom versions for high volume applications. Contact MEMSIC's local office for more information.

MXR7150VW SPECIFICATIONS (Measurements @ 25°C, Acceleration = 0 g unless otherwise noted; $V_{DD} = V_{DA} = 5.0V$ unless otherwise specified)

Parameter	Conditions	MXR7150VW			Units
		Min	Typ	Max	
SENSOR INPUT					
Measurement Range	Each Axis	-13.3		+13.3	g
Linearity			±0.5	±2	%
Transverse Sensitivity			±0.5	±2	%
SENSITIVITY					
Sensitivity, Analog Outputs at pins Xout and Y/Zout ^{1,2}	Each Axis @5.0V supply	140	150	160	mV/g
Change over Temperature	Δ from 25°C, -40°C to +125°C		±8	±10	%
Offset BIAS LEVEL					
Offset	Each Axis	-0.3	0	+0.3	g
Offset over Temperature	Δ from 25°C, -40°C to +125°C based on 150mV/g		±180	±300	mg
NOISE PERFORMANCE					
Noise, rms			8	12	mg
FREQUENCY RESPONSE					
3dB Bandwidth		26	29	32	Hz
SELF TEST					
Delta Output changes at Xout		2	3	4	g
Delta Output changes at Y/Zout		-2	-3	-4	g
Xout and Y/Zout OUTPUTS					
Normal Output Range (Guaranteed symmetric clipping)	@5.0V supply	0.5		4.5	V
Turn-On Time			100	250	ms
Resistance				100	ohm
POWER SUPPLY					
Operating Voltage Range	@ 5.0V supply	4.75	5.00	5.25	V
Supply Current ³			3.5	6.0	mA
Power Down Current			5	10	μA
TEMPERATURE RANGE					
Operating Range		-40		+125	°C
WEIGHT					
			197.30		mg

Note:

¹ Guaranteed by measurement of initial offset and sensitivity at room temperature.

² The device operates over a 4.75V to 5.25V supply range. The output zero g reference voltage scales 50% of the supply voltage. Sensitivity has a linear scale over the supply range of 4.75 to 5.25 volts according to the ratio $(V_{dd}/5.0 \text{ volts}) \times (150\text{mV/g})$.

Recommended to filter with a minimum of 200Hz low pass filter.

³ Note that the accelerometer has a constant heater power control circuit thereby requiring higher supply current at lower operating voltage.

ABSOLUTE MAXIMUM RATINGS*

Supply Voltage (V_{DD}, V_{DA}) ¹-0.5 to +7.0V
 Storage Temperature-55°C to +150°C
 Storage Pressure.....1,378 kPa
 Acceleration (any axis, Un-powered for 0.5 msec)..50,000 g
 Acceleration (any axis, Powered for 0.5 msec)... 10,000 g
 Output Short Circuit Duration, any pin to common.....Indefinite

*Stresses above those listed under Absolute Maximum Ratings may cause permanent damage to the device. This is a stress rating only; the functional operation of the device at these or any other conditions above those indicated in the operational sections of this specification is not implied. Exposure to absolute maximum rating conditions for extended periods may affect device reliability.

¹Exposure for up to 60 minutes to absolute maximum ratings for supply voltages will not affect device reliability.

ORDERING GUIDE

Model	Packing Style
MXR7150VW	Vertical mount tape reel
MXR7150VW-P	Flat mount tape reel

* Parts are shipped in tape and reel packaging.

PIN DESCRIPTION: LCC PACKAGE

Pin	Name	Description
1	Xout	X-Channel Ratiometric Output.
2	VDA	Analog Supply, V _{DA} and V _{DD} must be the same voltage .
3	VDD	Digital Supply, V _{DA} and V _{DD} must be the same voltage
4	FM	Ground. Connect to VSS. For factory use only.
5/J	PD	Power down.
6/M	Y/Zout	Y/Z-Channel Ratiometric Output
7/L	VSS	Ground
8/K	ST	Self -Test Input

Caution

ESD (electrostatic discharge) sensitive device.

ESD Compliance:

The MXR7150VW sensor is in compliance with the following ESD standards:
 HBM class H2 per AEC-Q100-002 Rev. E
 MM class M2 per AEC-Q100-003 Rev. E

XZ SENSING (TOP VIEW)

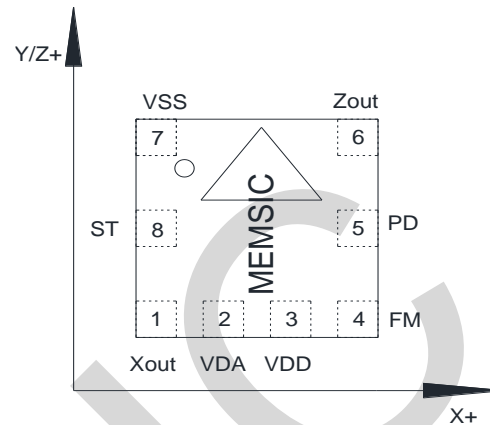

Note: The MEMSIC logo’s arrow indicates the +Z sensing direction of the device.

XZ(Y) SENSING (BOTTOM VIEW)

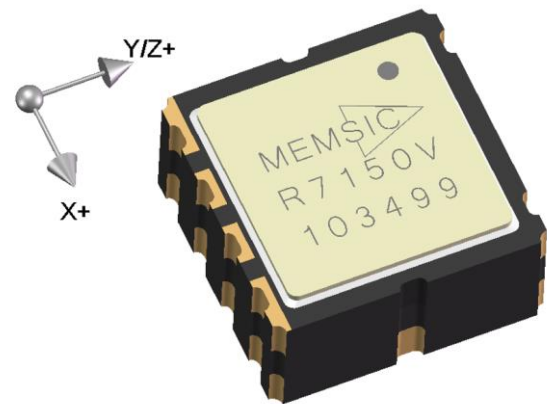
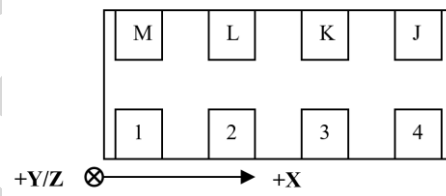

THEORY OF OPERATION

The MEMSIC device is a complete dual-axis acceleration measurement system fabricated on a monolithic CMOS IC process. The device operation is based on heat transfer by natural convection and operates like other accelerometers having a proof mass except it is a gas in the MEMSIC sensor.

A single heat source, centered in the silicon chip is suspended across a cavity. Equally spaced aluminum/polysilicon thermopiles (groups of thermocouples) are located equidistantly on all four sides of the heat source (dual axis). Under zero acceleration, a temperature gradient is symmetrical about the heat source, so that the temperature is the same at all four thermopiles, causing them to output the same voltage.

Acceleration in any direction will disturb the temperature profile, due to free convection heat transfer, causing it to be asymmetrical. The temperature, and hence voltage output of the four thermopiles will then be different. The differential voltage at the thermopile outputs is directly proportional to the acceleration. There are two identical acceleration signal paths on the MXR7150VW, one to measure acceleration in the x-axis and one to measure acceleration in the y/z-axis. For more details visit the MEMSIC website at www.MEMSIC.com for a picture/graphic description of the free convection heat transfer principle.

PIN DESCRIPTIONS

X_{OUT} – (pin 1) X-axis acceleration signal output.

V_{DA} – (pin 2) This is the analog power supply. This pin supplies current to the analog circuitry. The DC voltage should be equal to the voltage supplied to the V_{DD} pin.

V_{DD} - (pin 3) This is the digital power supply for the MXR7150VW. This pin supplies current to the heater element and digital circuitry. The DC voltage should be between 4.75V and 5.25V.

FM – (pin 4) Ground. Factory use only.

PD – (pin 5) Power down.

Y/Z_{OUT} – (pin 6) Y/Z-axis acceleration signal output.

VSS – (pin 7) This is the ground pin for the MXR7150VW

ST–(pin 8) Self –Test Input

This pin controls the self-test function of the sensor. Bringing ST_{IN} high will cause a deflection Y/Z_{out} and X_{out} from initial value.

SELF-TEST DESCRIPTION

The gas law governs the change in sensitivity over temperature.

All thermal accelerometers display the same sensitivity change with temperature. The sensitivity change depends on variations in heat transfer that are governed by the laws of physics. Manufacturing variations do not influence the sensitivity change, so there are no unit-to-unit differences in sensitivity change. The sensitivity change is governed by the following equation (and shown in Figure 1 in °C):

$$S_i \times T_i^{2.8} = k \times S_f \times T_f^{2.8}$$

where S_i is the sensitivity at any initial temperature T_i, and S_f is the sensitivity at any other final temperature T_f with the temperature values in °C, k is the ratio between uncompensated sensitivity and compensated sensitivity at 25°C.

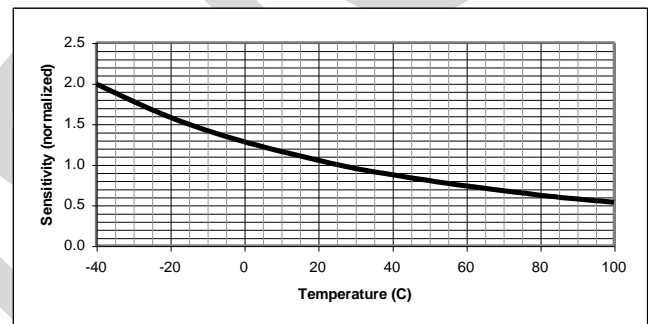

Thermal Accelerometer Sensitivity

Note1: When the temperature compensation is disabled and self-test is enabled. Self-test follows different gas law from sensitivity temperature dependence. It changes much smaller than sensitivity; this is why the temperature compensation is not done on self-test conditions.

Note2: Initial offset monitoring is a much better and reliable method to ensure sensor integrity, since it is ultra sensitive to sensor structure defect and damage. As long as initial offset is within specification the sensor is functioning correctly.

The sensor structure for the Thermal technology is guaranteed to fall outside the specified initial zero g offset parameters if the sensor is damaged or thermopile is failing.

The recommended method for verifying ST amplitude is as follows:

1. Read acceleration output on the desired axis -- call this Out1.
2. Pull ST high, which disables TC and activates ST.
3. Read acceleration output on the same axis(s) -- call this Out2.
4. Subtract (Out2—Out1). This is the ST signal amplitude.
5. Set ST low, returning the accelerometer to normal mode.

Using the above method, the presence of a real constant acceleration stimulus does not affect the ST amplitude, provided that the acceleration plus self-test signal is not so large that the signal path is saturated.

PCB LAYOUT AND FABRICATION SUGGESTIONS

Reference figure and the notes below for recommendations on connecting a power source to the MEMSIC device and PCB fabrication.

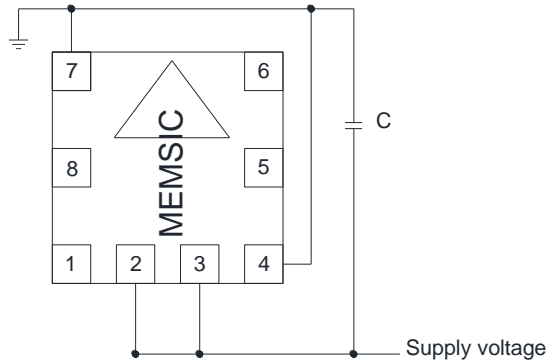

PCB Layout

Notes:

1. C = 1.0μF
2. The bypass capacitance should be placed near the VDD and VSS pins to ensure low noise performance and accurate outputs.
3. Robust low inductance ground and supply wiring should be used.
4. Care should be taken (like isolated rings and planes, signal route out perpendicular to the external thermal gradient) to ensure there is “thermal symmetry” on the PCB immediately surrounding the MEMSIC device and that there is no significant heat source nearby. This will minimize any errors in the measurement of acceleration.

SOLDER REFLOW PROFILE

1. Reflow is limited by 2 times. Second reflow should be applied after device has cooled down to room temperature (25°C).
2. Recommended reflow profile for Pb free process is shown in below figure. The time duration of peak temperature (260°C) should be limited to 10 seconds.

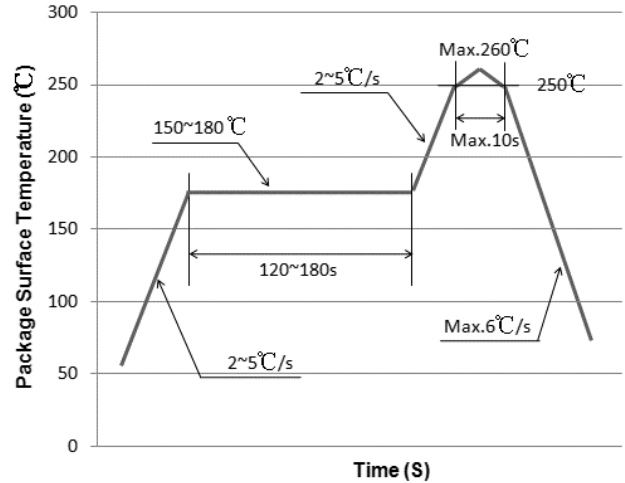

Recommended solder reflow profile

STENCIL DESIGN

1. It is recommended to use a stencil of thickness between 0.12mm~0.18mm. Stencil thickness should consider all devices on the PCB. It is suggested to select relatively thicker stencil to ensure adequate solder volume.
2. Stencil opening ratio is suggested between 0.8~1.4. 1:1 is a regular opening ratio. To increase the solder volume, a larger opening ratio is recommended.

END of LIFE DISPOSAL

End-of-life products should be disposed/ recycled properly in accordance to national and local regulation.

SUGGESTED LAND PATTERN

MXR7150VW Vertical Mount

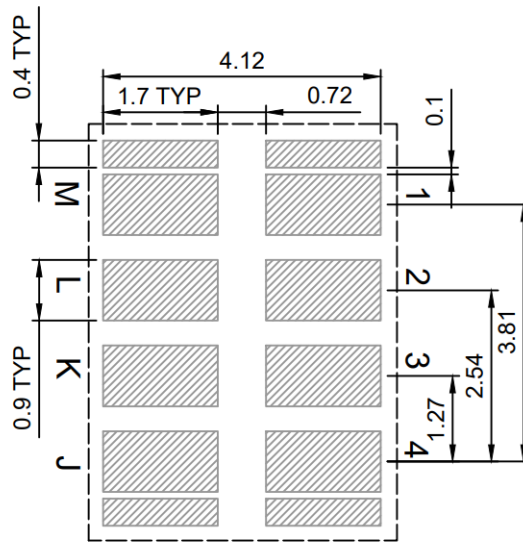

MXR7150VW Flat Mount

