

Double-Balanced Mixer

Rev. V2

Features

- LO 2.5 TO 7 GHz
- RF 2.5 TO 5.5 GHz
- IF DC TO 1.5 GHz
- LO DRIVE +9 dBm (nominal)
- LOW NOISE FIGURE 5.8 dB (TYP.)
-

Description

The MY63 is a double balanced mixer, designed for use in military, commercial and test equipment applications. The design utilizes Schottky ring quad diodes and broadband soft dielectric and ferrite baluns to attain excellent performance. This mixer can also be used as a phase detector and/or bi-phase modulator since the IF port is DC coupled to the diodes. The use of high temperature solder and welded assembly processes used internally makes it ideal for use in manual, semi-automated assembly. Environmental screening available to MIL-STD-883, MIL-STD-202, or MIL-DTL-28837, consult factory.

Product Image

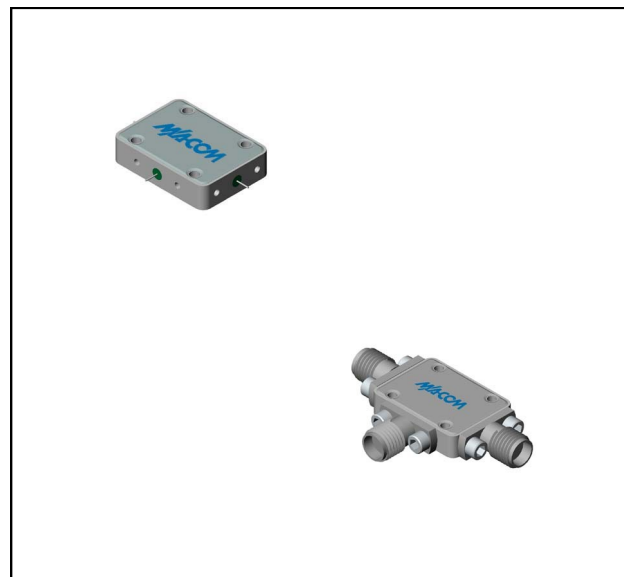

Ordering Information

Part Number	Package
MY63	Versapac
MY63C	SMA Connectorized

Electrical Specifications: $Z_0 = 50\Omega$ $L_o = +9$ dBm (Downconverter application only)

Parameter	Test Conditions	Units	Typical	Guaranteed	
				+25°C	-54° to +85°C
SSB Conversion Loss (max) & SSB Noise Figure (max)	fR = 3.0 to 5.0 GHz, fL = 3.0 to 5.5 GHz, fI = 0.03 to 0.5 GHz fR = 2.5 to 5.5 GHz, fL = 2.5 to 7.0 GHz, fI = 0.03 to 1.5 GHz	dB	5.0	6.0	6.5
			5.8	7.0	7.5
Isolation, L to R (min)	fL = 2.5 to 7 GHz	dB	40	30	28
Isolation, L to I (min)	fL = 2.5 to 3.5 GHz fL = 3.5 to 7 GHz	dB	25	17	15
		dB	30	20	18
1 dB Conversion Comp.	fL = +9 dBm	dBm	+2		
Input IP3	fR1 = 4 GHz at -10 dBm, fR2 = 4.01 GHz at -10 dBm, fL = 2.8 GHz at +9 dBm	dBm	+11		

Typical Performance Curves

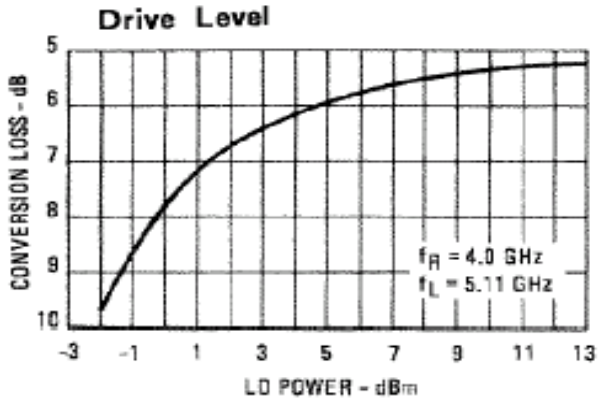

Drive Level: The maximum recommended drive level is +13 dBm.

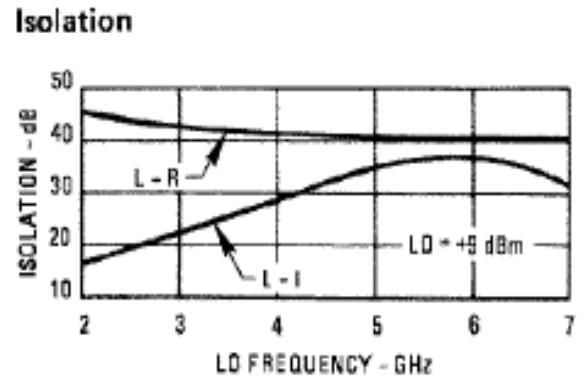
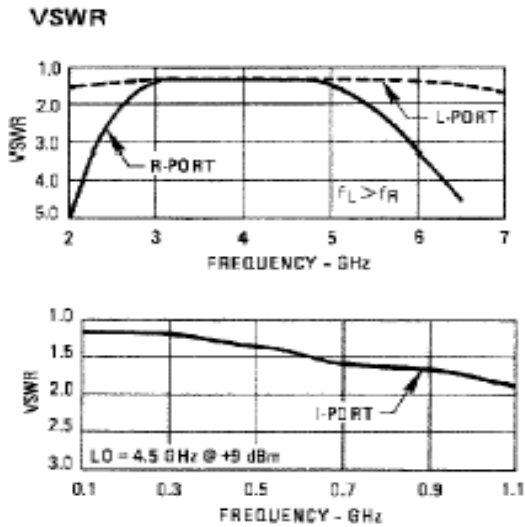
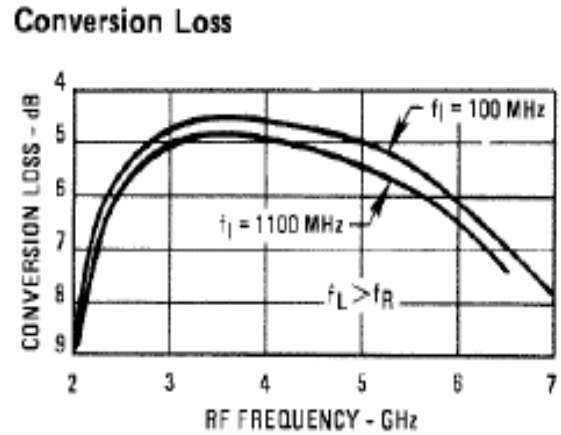

Double-Balanced Mixer

Rev. V2

Absolute Maximum Ratings

Parameter	Absolute Maximum
Operating Temperature	-54°C to +100°C
Storage Temperature	-65°C to +100°C
Peak Input Power	+23 dBm max @ +25°C dBm max @ +100°C
Peak Input Current	100 mA DC

Outline Drawing: Versapac *

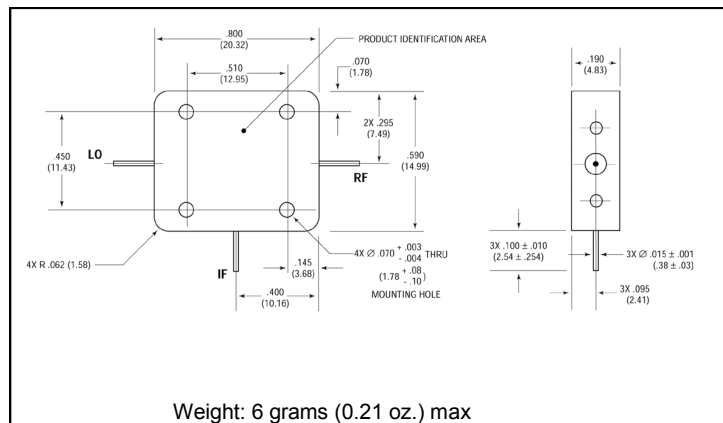

Outline Drawing: SMA Connectorized *

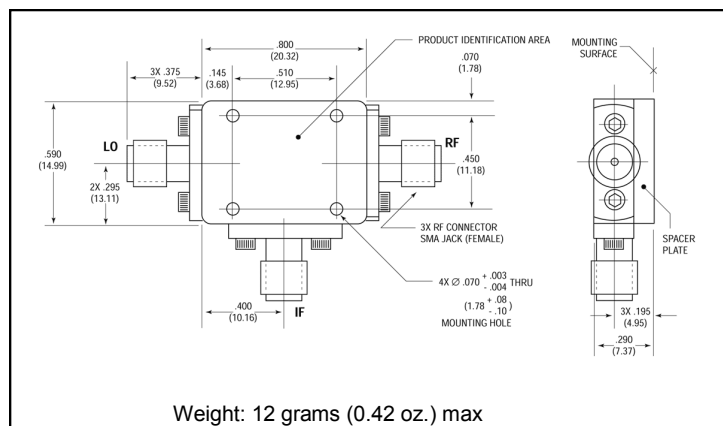

* Dimensions are inches (millimeters) ±0.015 (0.38) unless otherwise specified.