

## Triple-Balanced Mixer

Rev. V3

### Features

- LO 2 TO 18 GHz
- RF 2 TO 18 GHz
- IF 0.03 TO 5 GHz
- LO DRIVE: +10 dBm (NOMINAL)
- MINIATURE PACKAGE
- WIDE BANDWIDTH
- AVAILABLE WITH FIELD REPLACEABLE CONNECTORS

### Description

The MZ9310 is a triple balanced mixer, designed for use in military, commercial and test equipment applications. The design utilizes Schottky ring quad diodes and broadband soft dielectric baluns to attain excellent performance. The use of high temperature solder and welded assembly processes used internally makes it ideal for use in manual, semi-automated assembly. Environmental screening available to MIL-STD-883, MIL-STD-202 or MIL-DTL-28837, consult factory.

### Product Image

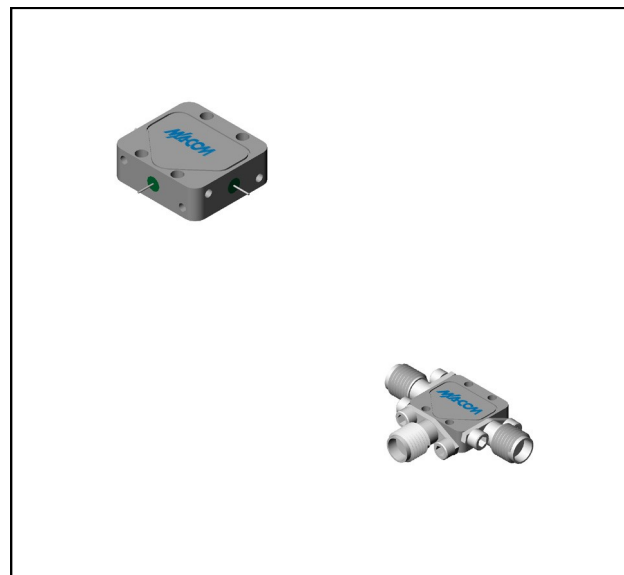

### Ordering Information

| Part Number | Package           |
|-------------|-------------------|
| MZ9310      | Versapac          |
| MZ9310C     | SMA Connectorized |

### Electrical Specifications: $Z_0 = 50\Omega$ $Lo = +10$ dBm (Downconverter application only)

| Parameter  | Test Conditions   | Units | Typical | Guaranteed |               |
|--|---|-------|---------|------------|---------------|
|  |   |       |         | +25°C      | -54° to +85°C |
| SSB Conversion Loss (max) & SSB Noise Figure (max) | fR = 4 to 18 GHz, fL = 4 to 18 GHz, fl = 0.03 to 1 GHz                      | dB    | 7.0     | 8.5        | 9.0           |
|  | fR = 3 to 18 GHz, fL = 3 to 18 GHz, fl = 0.03 to 2 GHz                      | dB    | 7.5     | 9.0        | 9.5           |
|  | fR = 3 to 18 GHz, fL = 3 to 18 GHz, fl = 0.03 to 3 GHz                      | dB    | 7.5     | 9.0        | 9.5           |
|  | fR = 2 to 18 GHz, fL = 2 to 18 GHz, fl = 0.03 to 5 GHz                      | dB    | 8.0     | 10.5       | 11.0          |
| Isolation, L to R (min)                            | fL = 2 to 4 GHz   | dB    | 20      | 12         | 10            |
|  | fL = 4 to 18 GHz  | dB    | 25      | 16         | 14            |
| Isolation, L to I (min)                            | fL = 2 to 18 GHz  | dB    | 30      | 16         | 14            |
| 1 dB Conversion Comp.                              | fL = +10 dBm  | dBm   | +6      |            |               |
| Input IP3  | fR1 = 3 GHz at -10 dBm, fR2 = 3.01 GHz at -10 dBm, fL = 5 GHz at +10 dBm    | dBm   | +16     |            |               |
|  | fR1 = 17.99 GHz at -10 dBm, fR2 = 18 GHz at -10 dBm, fL = 14 GHz at +10 dBm | dBm   | +13     |            |               |

### Typical Performance Curves

Conversion Loss vs. LO Power

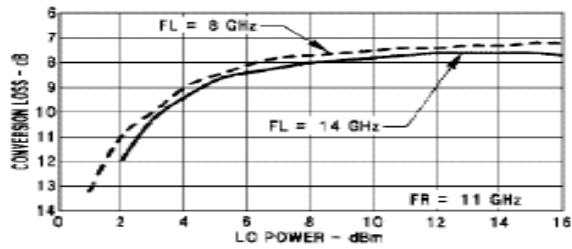

Conversion Loss vs. Frequency

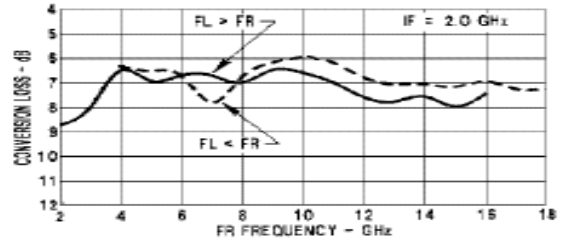

Conversion Loss vs. Frequency

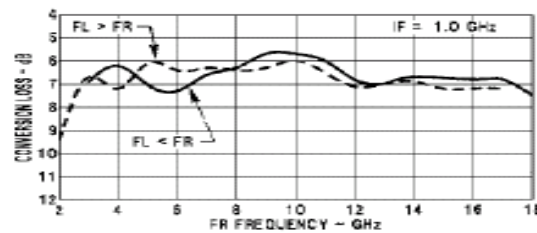
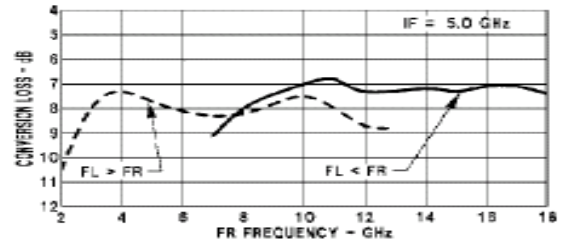
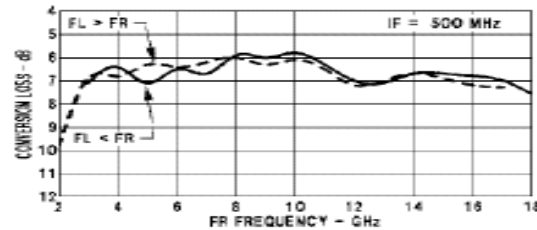
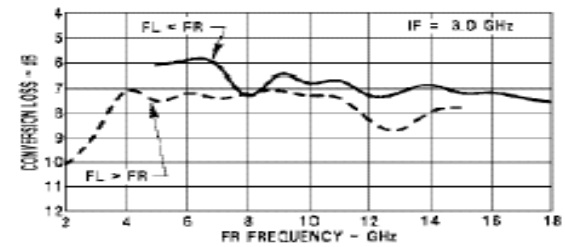
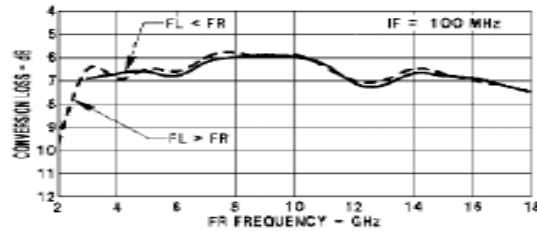

L-Port VSWR vs. Frequency

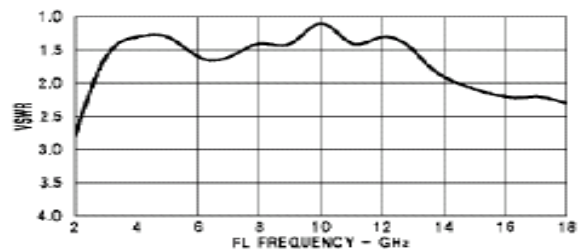

# MZ9310 / MZ9310C



## Triple-Balanced Mixer

Rev. V3

### Absolute Maximum Ratings

| Parameter             | Absolute Maximum                            |
|-----------------------|---|
| Operating Temperature | -54°C to +100°C                             |
| Storage Temperature   | -65°C to +100°C                             |
| Peak Input Power      | +26 dBm max @ +25°C<br>+23 dBm max @ +100°C |
| Peak Input Current    | mA DC                                       |

### Outline Drawing: Versapac \*

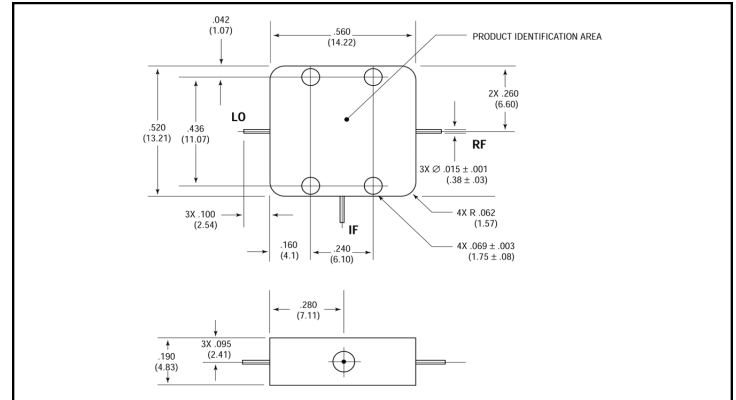

Weight: 4 grams (0.14 oz.) max

### Outline Drawing: SMA Connectorized \*

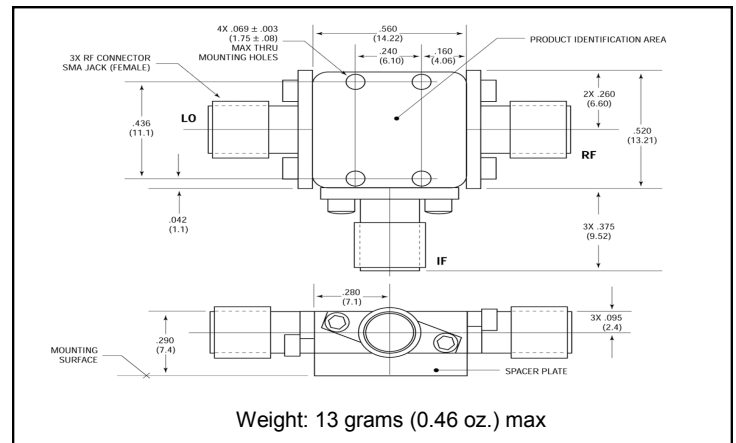

Weight: 13 grams (0.46 oz.) max

\* Dimensions are inches (millimeters) ±0.015 (0.38) unless otherwise specified.

Isolation vs. Frequency

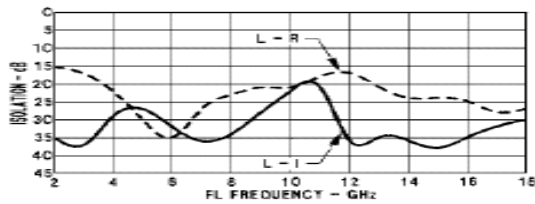

Isolation vs. Frequency

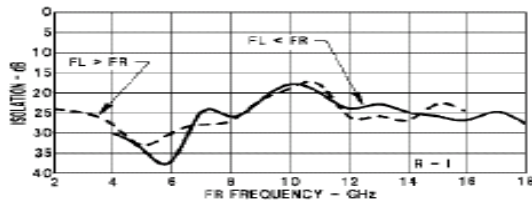

R-Port VSWR vs. Frequency

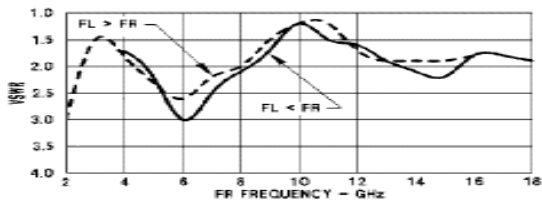

I-Port VSWR vs. Frequency

