



## General Description

The MxL83947 device is a 3 driver/5 receiver RS-232 transceiver intended for portable or hand-held applications such as notebook and industrial computers. The MxL83947 includes one complementary receiver that remains alert to monitor an external device's Ring Indicate signal while the device is shut down. The device is optimized for high speed with data rates up to 1Mbps, and low propagation delays and channel to channel skew, easily meeting the demands of high-performance RS-232 applications. The MxL83947 uses an internal high-efficiency charge-pump power supply that requires only 0.1 $\mu$ F capacitors for operation. This charge pump and MaxLinear's driver architecture allow the device to deliver compliant RS-232 performance from a single power supply ranging from +3.0V to +5.5V. The AUTO-ONLINE<sup>®</sup> feature allows the device to automatically *wake up* during a shutdown state when an RS-232 cable is connected and a connected peripheral is turned on. Otherwise, the device automatically shuts itself down, drawing less than 0.8 $\mu$ A.

## Features

- Meets true EIA/TIA-232-F standards from a +3.0V to +5.5V power supply
- Interoperable with EIA/TIA-232 and adheres to EIA/TIA-562 down to a +2.7V power source
- AUTO-ONLINE<sup>®</sup> circuitry automatically wakes up from a <0.8 $\mu$ A shutdown
- Regulated Charge Pump yields stable RS-232 outputs regardless of V<sub>CC</sub> variations
- Enhanced ESD specifications:
  - $\pm$ 15kV Human Body Model
  - $\pm$ 15kV IEC61000-4-2 Air Discharge
  - $\pm$ 8kV IEC61000-4-2 Contact Discharge
- 1000kbps minimum transmission rate
- Ideal for high-speed RS-232 applications

Ordering Information - [page 19](#)

## Selection Table

**Table 1: MxL83947 Selection Table**

| Power Supplies | RS-232 Drivers | RS-232 Receivers | External Components | AUTO-ONLINE <sup>®</sup> Circuitry | TTL 3-State | # of Pins | Data Rate (kbps) | ESD Rating |
|----------------|----------------|------------------|---------------------|------------------------------------|-------------|-----------|------------------|------------|
| +3.0V to +5.5V | 3              | 5                | 4 capacitors        | Yes                                | Yes         | 32        | 1000             | 15kV       |

## Revision History

| Revision | Release Date  | Change Description |
|----------|---------------|--------------------|
| 259DSR01 | June 16, 2022 | Initial release.   |

# Table of Contents

|   |           |
|---|-----------|
| <b>General Description</b> .....                  | <b>i</b>  |
| <b>Features</b> .....                             | <b>i</b>  |
| <b>Selection Table</b> .....                      | <b>i</b>  |
| <b>Specifications</b> .....                       | <b>1</b>  |
| Absolute Maximum Ratings.....                     | 1         |
| ESD Ratings .....                                 | 1         |
| Electrical Characteristics .....                  | 2         |
| <b>Typical Performance Characteristics</b> .....  | <b>4</b>  |
| <b>Pin Information</b> .....                      | <b>5</b>  |
| Pin Configuration.....                            | 5         |
| Pin Descriptions .....                            | 6         |
| <b>Typical Operating Circuit</b> .....            | <b>7</b>  |
| <b>Description</b> .....                          | <b>8</b>  |
| <b>Theory of Operation</b> .....                  | <b>9</b>  |
| Drivers .....                                     | 9         |
| Receivers .....                                   | 10        |
| Charge Pump .....                                 | 10        |
| Phase 1: $V_{SS}$ Charge Storage.....             | 10        |
| Phase 2: $V_{SS}$ Transfer.....                   | 10        |
| Phase 3: $V_{DD}$ Charge Storage .....            | 11        |
| Phase 4: $V_{DD}$ Transfer .....                  | 11        |
| AUTO-ONLINE <sup>®</sup> Circuitry.....           | 11        |
| ESD Tolerance .....                               | 15        |
| <b>Mechanical Dimensions</b> .....                | <b>17</b> |
| QFN32.....  | 17        |
| <b>Recommended Land Pattern and Stencil</b> ..... | <b>18</b> |
| QFN32.....  | 18        |
| <b>Ordering Information</b> .....                 | <b>19</b> |

## List of Figures

|   |    |
|---|----|
| Figure 1: Transmitter Skew vs. Load Capacitance.....                                  | 4  |
| Figure 2: Transmitter Output Voltage vs. Supply Voltage .....                         | 4  |
| Figure 3: Transmitter Output Voltage vs. Load Capacitance.....                        | 4  |
| Figure 4: Supply Current vs. Load Capacitance.....                                    | 4  |
| Figure 5: Supply Current vs. Supply Voltage.....                                      | 4  |
| Figure 6: Transmitter Output Voltage vs. Load Capacitance.....                        | 4  |
| Figure 7: Typical Slew Rate vs. Load Capacitance .....                                | 5  |
| Figure 8: MxL83947 Pinout (Top View) QFN32 .....                                      | 5  |
| Figure 9: MxL83947 Typical Operating Circuit .....                                    | 7  |
| Figure 10: Interface Circuitry Controlled by Microprocessor Supervisory Circuit ..... | 8  |
| Figure 11: Loopback Test Circuit for RS-232 Driver Data Transmission Rates .....      | 9  |
| Figure 12: Loopback Test Results at 1Mbps .....                                       | 9  |
| Figure 13: Charge Pump — Phase 1 .....  | 10 |
| Figure 14: Charge Pump — Phase 2 .....  | 10 |
| Figure 15: Charge Pump — Phase 3 .....  | 11 |
| Figure 16: Charge Pump — Phase 4 .....  | 11 |
| Figure 17: AUTO-ONLINE <sup>®</sup> Timing Waveforms.....                             | 12 |
| Figure 18: MxL83947 Driver Output Voltages vs. Load Current per Transmitter .....     | 12 |
| Figure 19: Mouse Drive Application.....   | 13 |
| Figure 20: Attaching MxL83947 to a DB-9 Connector.....                                | 13 |
| Figure 21: Stage I of AUTO-ONLINE <sup>®</sup> Circuitry .....                        | 14 |
| Figure 22: Stage II of AUTO-ONLINE <sup>®</sup> Circuitry .....                       | 14 |
| Figure 23: ESD Test Circuit for Human Body Model.....                                 | 16 |
| Figure 24: ESD Test Circuit for IEC61000-4-2 .....                                    | 16 |
| Figure 25: ESD Test Waveform for IEC61000-4-2.....                                    | 16 |
| Figure 26: Mechanical Dimensions, QFN32.....  | 17 |
| Figure 27: Recommended Land Pattern and Stencil, QFN32 .....                          | 18 |

## List of Tables

|  |    |
|--|----|
| Table 1: MxL83947 Selection Table .....                | i  |
| Table 2: Absolute Maximum Ratings .....                | 1  |
| Table 3: ESD Ratings .....                             | 1  |
| Table 4: Electrical Characteristics .....              | 2  |
| Table 5: Device Pin Descriptions .....                 | 6  |
| Table 6: MxL83947 SHUTDOWN Truth Table .....           | 10 |
| Table 7: Recommended Charge Pump Capacitor Value ..... | 11 |
| Table 8: AUTO-ONLINE <sup>®</sup> Logic .....          | 14 |
| Table 9: Transceiver ESD Tolerance Levels .....        | 16 |
| Table 10: Ordering Information .....                   | 19 |

## Specifications

### Absolute Maximum Ratings

**Important:** These are stress ratings only and functional operation of the device at these ratings or any other above those indicated in the operation sections of the specifications below is not implied. Exposure to absolute maximum ratings conditions for extended periods of time may affect reliability and cause permanent damage to the device.

**Table 2: Absolute Maximum Ratings**

| Parameter                                 | Minimum | Maximum        | Units |
|---|---------|----------------|-------|
| $V_{CC}$                                  | -0.3    | 6.0            | V     |
| $V_{+}^{(1)}$                             | -0.3    | 7.0            | V     |
| $V_{-}^{(1)}$                             | +0.3    | -7.0           | V     |
| $V_{+} +  V_{-} ^{(1)}$                   |         | +13            | V     |
| $I_{CC}$ (DC $V_{CC}$ or GND current)     |         | $\pm 100$      | mA    |
| Input Voltages                            |         |                |       |
| TxIN, <u>ONLINE</u> , <u>SHUTDOWN</u>     | -0.3    | 6.0            | V     |
| RxIN                                      |         | $\pm 25$       | V     |
| Output Voltages                           |         |                |       |
| TxOUT                                     |         | $\pm 13.2$     | V     |
| RxOUT, <u>STATUS</u>                      | -0.3    | $V_{CC} + 0.3$ | V     |
| Short-Circuit Duration                    |         |                |       |
| TxOUT                                     |         | Continuous     |       |
| Temperature                               |         |                |       |
| Storage temperature                       | -65     | 150            | °C    |
| Power Dissipation per Package             |         |                |       |
| 32-pin QFN (derate 29.4mW/°C above +70°C) |         | 2352           | mW    |

1.  $V_{+}$  and  $V_{-}$  can have maximum magnitudes of 7V, but their absolute difference cannot exceed 13V.

### ESD Ratings

**Table 3: ESD Ratings**

| Parameter   | Level | Value    | Units |
|---|-------|----------|-------|
| HBM — Human Body Model (driver outputs and receiver inputs)         |       | $\pm 15$ | kV    |
| IEC61000-4-2 Air Discharge (driver outputs and receiver inputs)     | 4     | $\pm 15$ | kV    |
| IEC61000-4-2 Contact Discharge (driver outputs and receiver inputs) | 4     | $\pm 8$  | kV    |

## Electrical Characteristics

Unless otherwise noted, the following specifications apply for  $V_{CC} = +3.0V$  to  $+5.5V$  with  $T_{AMB} = T_{MIN}$  to  $T_{MAX}$ ,  $C1 - C4 = 0.1\mu F$ . Typical values apply at  $V_{CC} = +3.3V$  or  $+5.0V$  and  $T_{AMB} = 25^{\circ}C$ .

**Table 4: Electrical Characteristics**

| Parameter                                | Test Condition   | Minimum   | Typical        | Maximum   | Units     |
|--|--|---|----------------|-----------|-----------|
| <b>DC Characteristics</b>                |  |   |                |           |           |
| Supply current, AUTO-ONLINE®             | All RxIN open, $\overline{ONLINE} = GND$ ,<br>$\overline{SHUTDOWN} = V_{CC}$ , $V_{CC} = 3.3V$ , $T_{AMB} = 25^{\circ}C$ ,<br>$TxIN = GND$ or $V_{CC}$ |   | 0.2            | 0.8       | $\mu A$   |
| Supply current, shutdown                 | $\overline{SHUTDOWN} = GND$ , $V_{CC} = 3.3V$ , $T_{AMB} = 25^{\circ}C$ ,<br>$TxIN = V_{CC}$ or $GND$  |   | 0.2            | 0.8       | $\mu A$   |
| Supply current, AUTO-ONLINE® disabled    | $\overline{ONLINE} = \overline{SHUTDOWN} = V_{CC}$ , no load,<br>$V_{CC} = 3.3V$ , $T_{AMB} = +25^{\circ}C$ , $TxIN = GND$ or $V_{CC}$                 |   | 0.6            | 1.0       | mA        |
| <b>Logic Inputs and Receiver Outputs</b> |  |   |                |           |           |
| Input logic threshold                    | Low  | $V_{CC} = 3.3V$ or $5.0V$ , $TxIN$ , $\overline{ONLINE}$ ,<br>$\overline{SHUTDOWN}$ |                | 0.8       | V         |
|  | High   |   | 2.4            |           | V         |
| Input leakage current                    | $TxIN$ , $\overline{ONLINE}$ , $\overline{SHUTDOWN}$ , $T_{AMB} = +25^{\circ}C$ ,<br>$V_{IN} = 0V$ to $V_{CC}$   |   | $\pm 0.01$     | $\pm 1.0$ | $\mu A$   |
| Output leakage current                   | Receivers disabled, $V_{OUT} = 0V$ to $V_{CC}$   |   | $\pm 0.05$     | $\pm 10$  | $\mu A$   |
| Output voltage Low                       | $I_{OUT} = 1.6mA$  |   |                | 0.4       | V         |
| Output voltage High                      | $I_{OUT} = -1.0mA$   | $V_{CC} - 0.6$  | $V_{CC} - 0.1$ |           | V         |
| <b>Driver Outputs</b>                    |  |   |                |           |           |
| Output voltage swing                     | All driver outputs loaded with $3k\Omega$ to $GND$ ,<br>$T_{AMB} = +25^{\circ}C$   | $\pm 5.0$   | $\pm 5.4$      |           | V         |
| Output resistance                        | $V_{CC} = V+ = V- = 0V$ , $V_{OUT} = \pm 2V$   | 300   |                |           | $\Omega$  |
| Output short-circuit current             | $V_{OUT} = 0V$   |   | $\pm 35$       | $\pm 60$  | mA        |
| Output leakage current                   | $V_{CC} = 0V$ or $3.0V$ to $5.5V$ , $V_{OUT} = \pm 12V$ ,<br>drivers disabled  |   |                | $\pm 25$  | $\mu A$   |
| <b>Receiver Inputs</b>                   |  |   |                |           |           |
| Input voltage range                      |  | -20   |                | 20        | V         |
| Input threshold Low                      | $V_{CC} = 3.3V$  | 0.6   | 1.2            |           | V         |
|  | $V_{CC} = 5.0V$  | 0.8   | 1.5            |           | V         |
| Input threshold High                     | $V_{CC} = 3.3V$  |   | 1.5            | 2.4       | V         |
|  | $V_{CC} = 5.0V$  |   | 1.8            | 2.4       | V         |
| Input hysteresis                         |  |   | 0.3            |           | V         |
| Input resistance                         |  | 3   | 5              | 7         | $k\Omega$ |

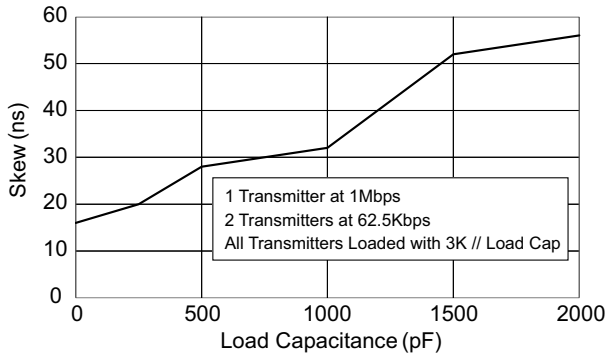
**Table 4: Electrical Characteristics**

| Parameter  | Test Condition  | Minimum  | Typical | Maximum | Units            |
|--|---|--|---------|---------|------------------|
| AUTO-ONLINE <sup>®</sup> Circuitry Characteristics ( $\overline{\text{ONLINE}} = \text{GND}$ , $\overline{\text{SHUTDOWN}} = V_{\text{CC}}$ ) 25°C |   |  |         |         |                  |
| $\overline{\text{STATUS}}$ output voltage Low  | $I_{\text{OUT}} = 1.6\text{mA}$   |  |         | 0.4     | V                |
| $\overline{\text{STATUS}}$ output voltage High   | $I_{\text{OUT}} = -1.0\text{mA}$  | $V_{\text{CC}} - 0.6$  |         |         | V                |
| Receiver threshold to drivers enabled ( $t_{\text{ONLINE}}$ )  | Figure 17   |  | 50      |         | $\mu\text{s}$    |
| Receiver positive or negative threshold to $\overline{\text{STATUS}}$ High ( $t_{\text{STSH}}$ )   | Figure 17   |  | 0.2     |         | $\mu\text{s}$    |
| Receiver positive or negative threshold to $\overline{\text{STATUS}}$ Low ( $t_{\text{STSL}}$ )  | Figure 17   |  | 30      |         | $\mu\text{s}$    |
| Timing Characteristics   |   |  |         |         |                  |
| Maximum data rate  | $R_{\text{L}} = 3\text{k}\Omega$ , $C_{\text{L}} = 250\text{pF}$ , one driver active  | 1000   |         |         | kbps             |
| Receiver propagation delay   | $t_{\text{PHL}}$  | Receiver input to receiver output, $C_{\text{L}} = 150\text{pF}$ | 0.15    |         | $\mu\text{s}$    |
|  | $t_{\text{PLH}}$  |  | 0.15    |         | $\mu\text{s}$    |
| Receiver output enable time  | Normal operation  |  | 200     |         | ns               |
| Receiver output disable time   | Normal operation  |  | 200     |         | ns               |
| Driver skew  | $ t_{\text{PHL}} - t_{\text{PLH}} $   |  | 10      | 50      | ns               |
| Receiver skew  | $ t_{\text{PHL}} - t_{\text{PLH}} $   |  | 10      |         | ns               |
| Transition-region slew rate  | $V_{\text{CC}} = 3.3\text{V}$ , $R_{\text{L}} = 3\text{k}\Omega$ , $T_{\text{AMB}} = 25^\circ\text{C}$ , measurements taken from -3.0V to +3.0V or +3.0V to -3.0V |  | 90      |         | V/ $\mu\text{s}$ |

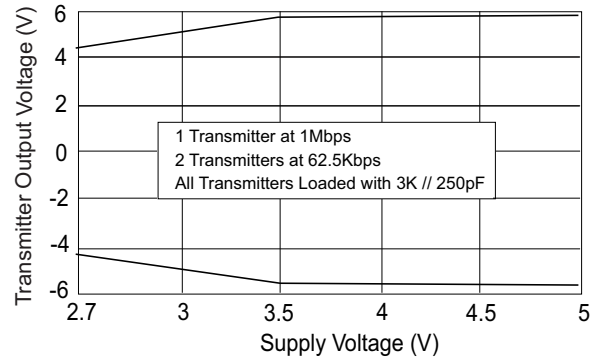


## Typical Performance Characteristics

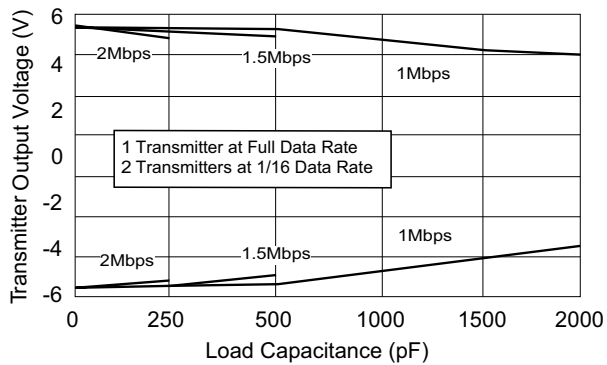
Unless otherwise noted, the following performance characteristics apply for  $V_{CC} = +3.3V$ , 1000kbps data rate, all transmitters loaded with  $3k\Omega$ ,  $0.1\mu F$  charge pump capacitors, and  $T_{AMB} = +25^{\circ}C$ .



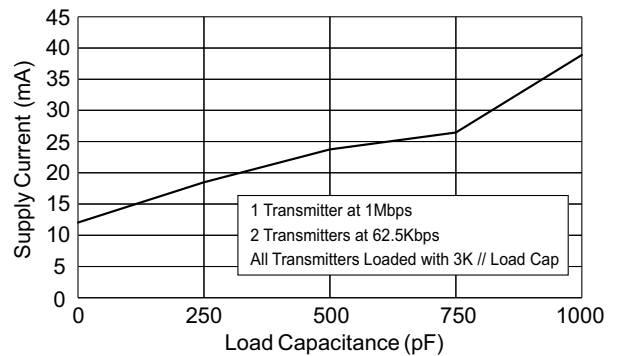
**Figure 1: Transmitter Skew vs. Load Capacitance**



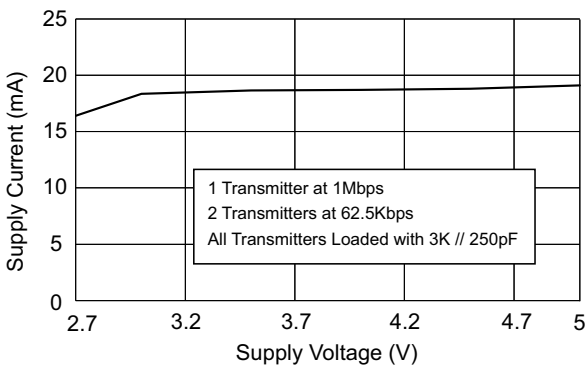
**Figure 2: Transmitter Output Voltage vs. Supply Voltage**



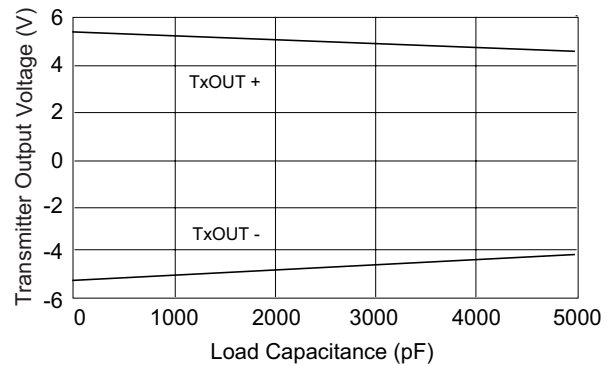
**Figure 3: Transmitter Output Voltage vs. Load Capacitance**



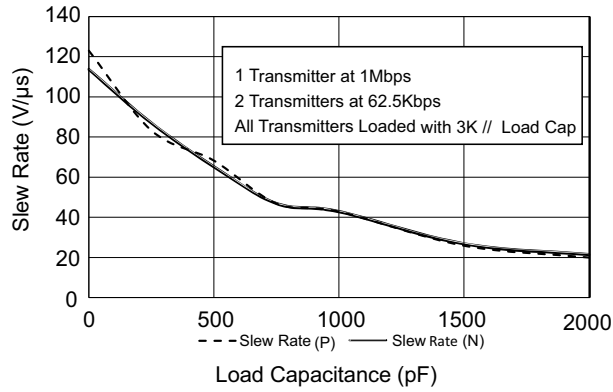
**Figure 4: Supply Current vs. Load Capacitance**



**Figure 5: Supply Current vs. Supply Voltage**



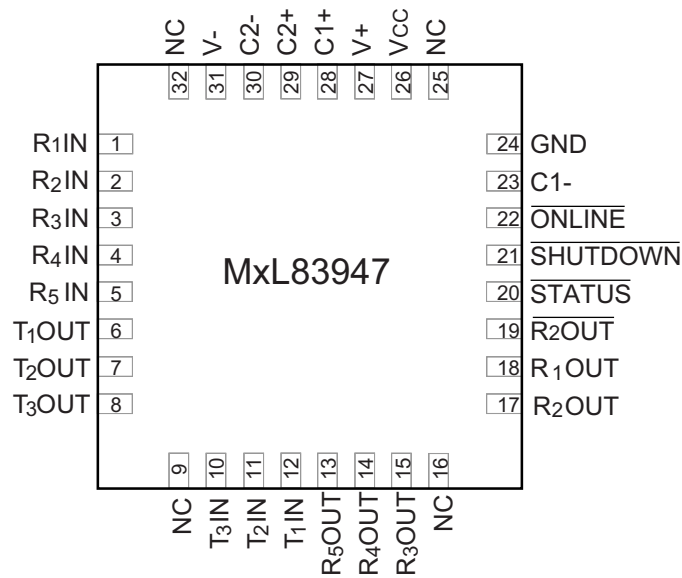
**Figure 6: Transmitter Output Voltage vs. Load Capacitance**



**Figure 7: Typical Slew Rate vs. Load Capacitance**

## Pin Information

### Pin Configuration



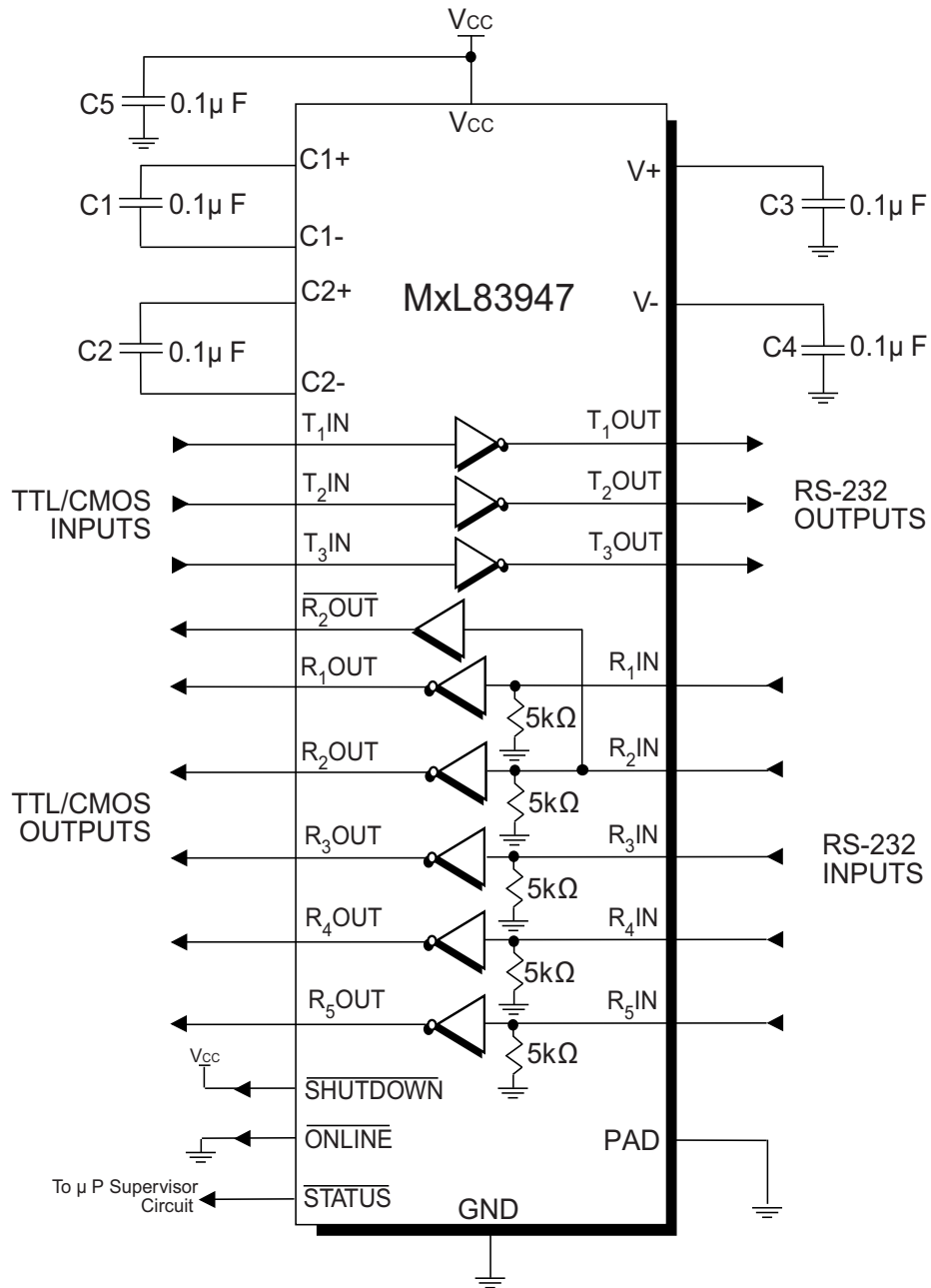
**Figure 8: MxL83947 Pinout (Top View) QFN32**

## Pin Descriptions

**Table 5: Device Pin Descriptions**

| Name                  | Function   | MxL83947 QFN  |
|-----------------------|--|---------------|
| C1+                   | Positive terminal of the voltage doubler charge-pump capacitor   | 28            |
| V+                    | Regulated +5.5V output generated by the charge pump  | 27            |
| C1-                   | Negative terminal of the voltage doubler charge-pump capacitor   | 23            |
| C2+                   | Positive terminal of the inverting charge-pump capacitor   | 29            |
| C2-                   | Negative terminal of the inverting charge-pump capacitor   | 30            |
| V-                    | Regulated -5.5V output generated by the charge pump  | 31            |
| R <sub>1</sub> IN     | RS-232 receiver input  | 1             |
| R <sub>2</sub> IN     | RS-232 receiver input  | 2             |
| R <sub>3</sub> IN     | RS-232 receiver input  | 3             |
| R <sub>4</sub> IN     | RS-232 receiver input  | 4             |
| R <sub>5</sub> IN     | RS-232 receiver input  | 5             |
| R <sub>1</sub> OUT    | TTL/CMOS receiver output   | 18            |
| R <sub>2</sub> OUT    | TTL/CMOS receiver output   | 17            |
| $\overline{R_2}$ OUT  | Non-inverting receiver-2 output, active in shutdown  | 19            |
| R <sub>3</sub> OUT    | TTL/CMOS receiver output   | 15            |
| R <sub>4</sub> OUT    | TTL/CMOS receiver output   | 14            |
| R <sub>5</sub> OUT    | TTL/CMOS receiver output   | 13            |
| $\overline{STATUS}$   | TTL/CMOS output indicating online and shutdown status  | 20            |
| T <sub>1</sub> IN     | TTL/CMOS driver input  | 12            |
| T <sub>2</sub> IN     | TTL/CMOS driver input  | 11            |
| T <sub>3</sub> IN     | TTL/CMOS driver input  | 10            |
| $\overline{ONLINE}$   | Apply logic HIGH to override AUTO-ONLINE <sup>®</sup> circuitry keeping drivers active ( $\overline{SHUTDOWN}$ must also be logic HIGH, refer to <a href="#">Table 6</a> )         | 22            |
| T <sub>1</sub> OUT    | RS-232 driver output   | 6             |
| T <sub>2</sub> OUT    | RS-232 driver output   | 7             |
| T <sub>3</sub> OUT    | RS-232 driver output   | 8             |
| GND                   | Ground   | 24            |
| V <sub>CC</sub>       | +3.0V to +5.5V supply voltage  | 26            |
| $\overline{SHUTDOWN}$ | Apply logic LOW to $\overline{SHUTDOWN}$ driver and charge pump. This overrides all AUTO-ONLINE <sup>®</sup> circuitry and $\overline{ONLINE}$ (Refer to <a href="#">Table 6</a> ) | 21            |
| NC                    | No connection  | 9, 16, 25, 32 |
| PAD                   | Exposed thermal PAD on QFN package. Connect to GND.  | -             |

# Typical Operating Circuit



**Figure 9: MxL83947 Typical Operating Circuit**

## Description

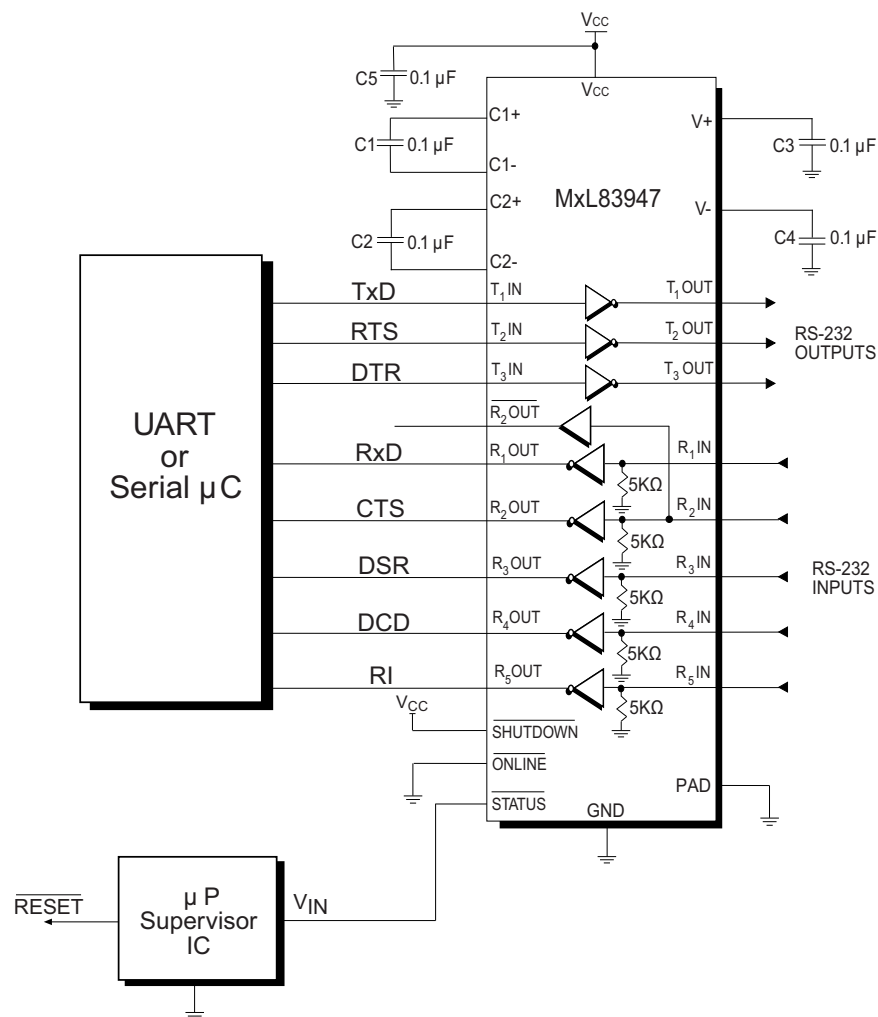
The MxL83947 transceiver meets the EIA/TIA-232 and ITU-T V.28/V.24 communication protocols and can be implemented in battery-powered, portable or hand-held applications such as notebook or palmtop computers. The MxL83947 device features MaxLinear's proprietary and patented (U.S. 5,306,954) on-board charge pump circuitry that generates  $\pm 5.5\text{V}$  RS-232 voltage levels from a single  $+3.0\text{V}$  to  $+5.5\text{V}$  power supply. The MxL83947 device can operate at a data rate of 1000kbps fully loaded.

The MxL83947 is a 3 driver/5 receiver device, ideal for portable or hand-held applications. The device includes one complementary always-active receiver that can monitor an external device (such as a modem) in shutdown. This aids in protecting the UART or serial

controller IC by preventing forward biasing of the protection diodes where  $V_{CC}$  may be disconnected.

The MxL83947 device is an ideal choice for power sensitive designs. It features AUTO-ONLINE<sup>®</sup> circuitry which reduces the power supply drain to less than  $0.8\mu\text{A}$  supply current.

In many portable or hand-held applications, an RS-232 cable can be disconnected or a connected peripheral can be turned off. Under these conditions, the internal charge pump and the drivers will be shut down. Otherwise, the system automatically comes online. This feature allows design engineers to address power saving concerns without major design changes.



**Figure 10: Interface Circuitry Controlled by Microprocessor Supervisory Circuit**

# Theory of Operation

The MxL83947 device is made up of four basic circuit blocks:

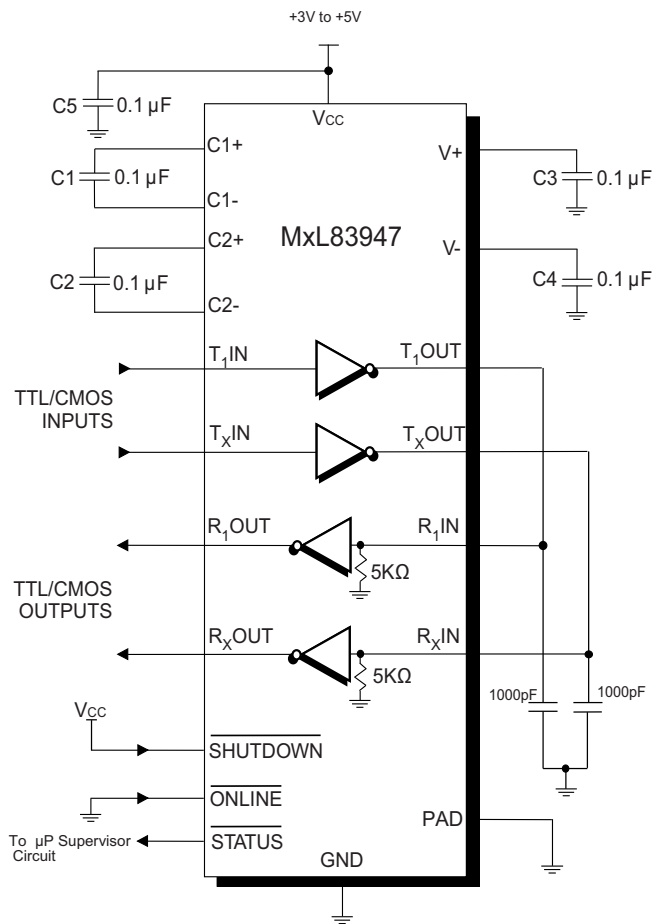
1. Drivers
2. Receivers
3. The MaxLinear proprietary charge pump
4. AUTO-ONLINE<sup>®</sup> circuitry

## Drivers

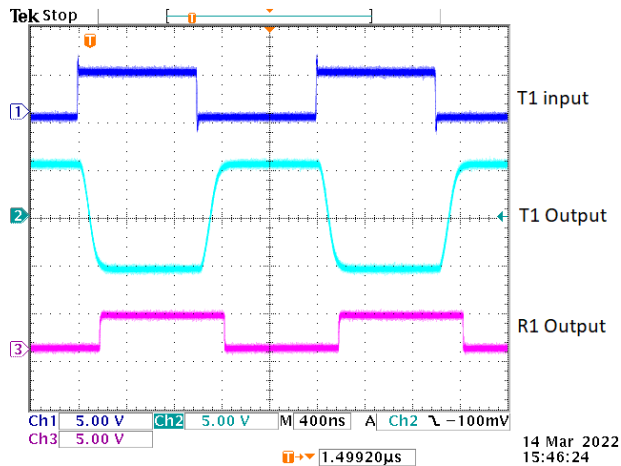
The drivers are inverting level transmitters that convert TTL or CMOS logic levels to 5.0V EIA/TIA-232 levels with an inverted sense relative to the input logic levels. Typically, the RS-232 output voltage swing is  $\pm 5.4V$  with no load and  $\pm 5V$  minimum fully loaded. The driver outputs are protected against infinite short-circuits to ground without degradation in reliability. These drivers comply with the EIA-TIA-232-F and all previous RS-232 versions. Unused drivers inputs should be connected to GND or  $V_{CC}$ .

The drivers have a minimum data rate of 1000kbps fully loaded.

Figure 11 shows a loopback test circuit used to test the RS-232 Drivers. Figure 12 shows the test results where one driver was active at 1Mbps and all three drivers were loaded with an RS-232 receiver in parallel with a 250pF capacitor. A superior RS-232 data transmission rate of 1Mbps makes the MxL83947 an ideal match for high-speed LAN and personal computer peripheral applications.



**Figure 11: Loopback Test Circuit for RS-232 Driver Data Transmission Rates**



**Figure 12: Loopback Test Results at 1Mbps**

## Receivers

The receivers convert  $\pm 5.0\text{V}$  EIA/TIA-232 levels to TTL or CMOS logic output levels. Receivers are High-Z when the AUTO-ONLINE<sup>®</sup> circuitry is enabled or when in shutdown. The truth table logic of the MxL83947 driver and receiver outputs can be found in [Table 6](#).

**Table 6: MxL83947 SHUTDOWN Truth Table**

| SHUTDOWN | TxOUT  | RxOUT  | R2OUT  |
|----------|--------|--------|--------|
| 0        | High-Z | High-Z | Active |
| 1        | Active | Active | Active |

1. In AUTO-ONLINE<sup>®</sup> Mode where  $\overline{\text{ONLINE}} = \text{GND}$  and  $\overline{\text{SHUTDOWN}} = V_{\text{CC}}$ , the device will shut down if there is no activity present at the receiver inputs.

The MxL83947 includes an additional non-inverting receiver with an output  $\overline{\text{R2OUT}}$ .  $\overline{\text{R2OUT}}$  is an extra output that remains active and monitors activity while the other receiver outputs are forced into high impedance. This allows a Ring Indicator (RI) signal from a peripheral to be monitored without forward biasing the TTL/CMOS inputs of the other devices connected to the receiver outputs.

Since receiver input is usually from a transmission line where long cable lengths and system interference can degrade the signal, the inputs have a typical hysteresis margin of 300mV. This ensures that the receiver is virtually immune to noisy transmission lines. Should an input be left unconnected, an internal 5k $\Omega$  pull-down resistor to ground will commit the output of the receiver to a HIGH state.

## Charge Pump

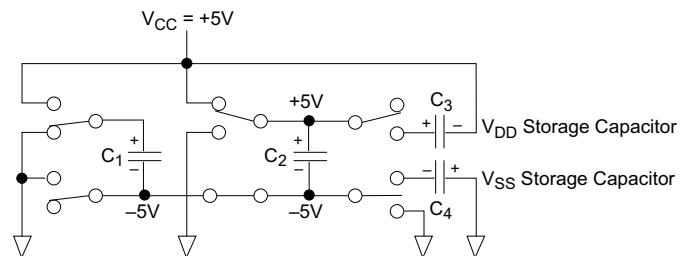
The charge pump is a MaxLinear-patented design (U.S. 5,306,954) and uses a unique approach compared to older, less-efficient designs. The charge pump still requires four external capacitors, but uses a four-phase voltage shifting technique to attain symmetrical 5.5V power supplies. The internal power supply consists of a regulated dual charge pump that provides output voltages of 5.5V regardless of the input voltage ( $V_{\text{CC}}$ ) over the +3.0V to +5.5V range. This is important to maintain compliant RS-232 levels regardless of power supply fluctuations.

The charge pump operates in a discontinuous mode using an internal oscillator. If the output voltages are less than a magnitude of 5.5V, the charge pump is enabled. If the output voltages exceed a magnitude of 5.5V, the charge

pump is disabled. This oscillator controls the four phases of the voltage shifting. A description of each phase follows.

### Phase 1: $V_{\text{SS}}$ Charge Storage

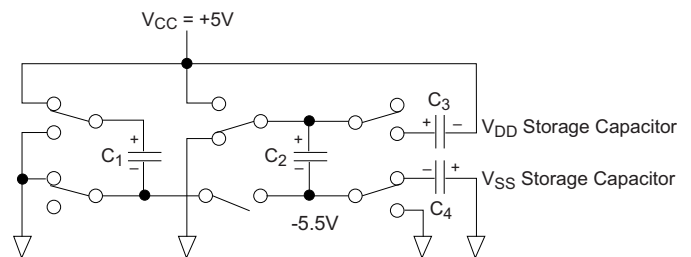
During this phase of the clock cycle, the positive side of capacitors  $C_1$  and  $C_2$  are initially charged to  $V_{\text{CC}}$ .  $C_1^+$  is then switched to GND and the charge in  $C_1^-$  is transferred to  $C_2^-$ . Since  $C_2^+$  is connected to  $V_{\text{CC}}$ , the voltage potential across capacitor  $C_2$  is now 2 times  $V_{\text{CC}}$ .



**Figure 13: Charge Pump — Phase 1**

### Phase 2: $V_{\text{SS}}$ Transfer

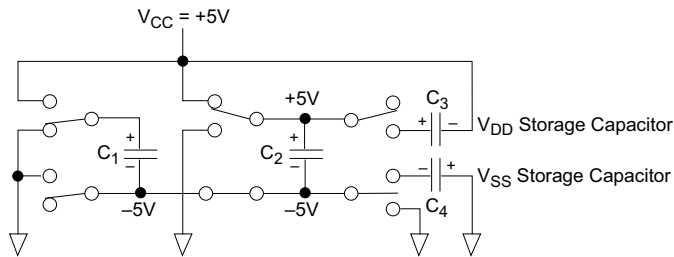
Phase two of the clock connects the negative terminal of  $C_2$  to the  $V_{\text{SS}}$  storage capacitor and the positive terminal of  $C_2$  to GND. This transfers a negative generated voltage to  $C_3$ . This generated voltage is regulated to a minimum voltage of -5.5V. Simultaneous with the transfer of the voltage to  $C_3$ , the positive side of capacitor  $C_1$  is switched to  $V_{\text{CC}}$  and the negative side is connected to GND.



**Figure 14: Charge Pump — Phase 2**

## Phase 3: $V_{DD}$ Charge Storage

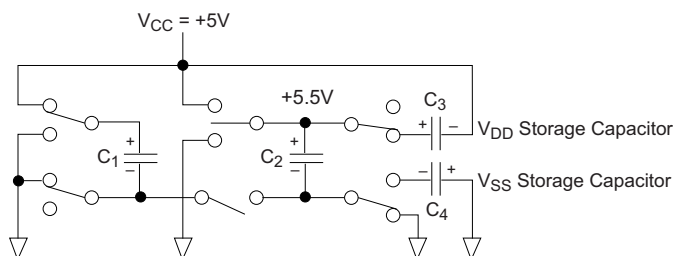
The third phase of the clock is identical to the first phase — the charge transferred in  $C_1$  produces  $-V_{CC}$  in the negative terminal of  $C_1$ , which is applied to the negative side of capacitor  $C_2$ . Since  $C_2^+$  is at  $V_{CC}$ , the voltage potential across  $C_2$  is 2 times  $V_{CC}$ .



**Figure 15: Charge Pump — Phase 3**

## Phase 4: $V_{DD}$ Transfer

The fourth phase of the clock connects the negative terminal of  $C_2$  to GND, and transfers this positive generated voltage across  $C_2$  to  $C_4$ , the  $V_{DD}$  storage capacitor. This voltage is regulated to +5.5V. At this voltage, the internal oscillator is disabled. Simultaneous with the transfer of the voltage to  $C_4$ , the positive side of capacitor  $C_1$  is switched to  $V_{CC}$  and the negative side is connected to GND, allowing the charge pump cycle to begin again. The charge pump cycle will continue as long as the operational conditions for the internal oscillator are present.



**Figure 16: Charge Pump — Phase 4**

Since both  $V^+$  and  $V^-$  are separately generated from  $V_{CC}$ , in a no-load condition  $V^+$  and  $V^-$  will be symmetrical. Older charge pump approaches that generate  $V^-$  from  $V^+$  will show a decrease in the magnitude of  $V^-$  compared to  $V^+$  due to the inherent inefficiencies in the design. The

clock rate for the charge pump typically operates at greater than 250kHz. The external capacitors can be as low as 0.1 $\mu$ F with a 16V breakdown voltage rating.

**Table 7: Recommended Charge Pump Capacitor Value**

| Input Voltage $V_{CC}$ | Charge Pump Capacitor Value                              |
|------------------------|--|
| 3.0V to 3.6V           | $C_1 - C_4 = 0.1\mu\text{F}$                             |
| 4.5V to 5.5V           | $C_1 = 0.047\mu\text{F}$ , $C_2 - C_4 = 0.33\mu\text{F}$ |
| 3.0V to 5.5V           | $C_1 - C_4 = 0.22\mu\text{F}$                            |

The MaxLinear-patented charge pumps are designed to operate reliably with a range of low cost capacitors. Either polarized or non polarized capacitors may be used. If polarized capacitors are used they should be oriented as shown in the Typical Operating Circuit. The  $V^+$  capacitor may be connected to either ground or  $V_{CC}$  (polarity reversed.)

The charge pump operates with 0.1 $\mu$ F capacitors ( $C_1 \sim C_4$ ). For other supply voltages, see the table for recommended capacitor values. Increasing the capacitor values (for example, by doubling in value) reduces ripple on the transmitter outputs and may slightly reduce power consumption.  $C_2$ ,  $C_3$ , and  $C_4$  can be increased without changing  $C_1$ 's value.

For best charge pump efficiency, locate the charge pump and bypass capacitors as close as possible to the IC. Surface mount capacitors are best for this purpose. Using capacitors with lower equivalent series resistance (ESR) and self-inductance, along with minimizing parasitic PCB trace inductance, will optimize charge pump operation. Designers are also advised to consider that capacitor values may shift over time and operating temperature.

## AUTO-ONLINE<sup>®</sup> Circuitry

The MxL83947 device has a patent pending AUTO-ONLINE<sup>®</sup> circuitry on board that saves power in applications such as laptop computers, palmtop (PDA) computers and other portable systems.

The MxL83947 device incorporates an AUTO-ONLINE<sup>®</sup> circuit that automatically enables itself when the external transmitters are enabled and the cable is connected. Conversely, the AUTO-ONLINE<sup>®</sup> circuit also disables most of the internal circuitry when the device is not being used and goes into a standby mode where the device typically draws less than 0.8 $\mu$ A. This function is externally controlled

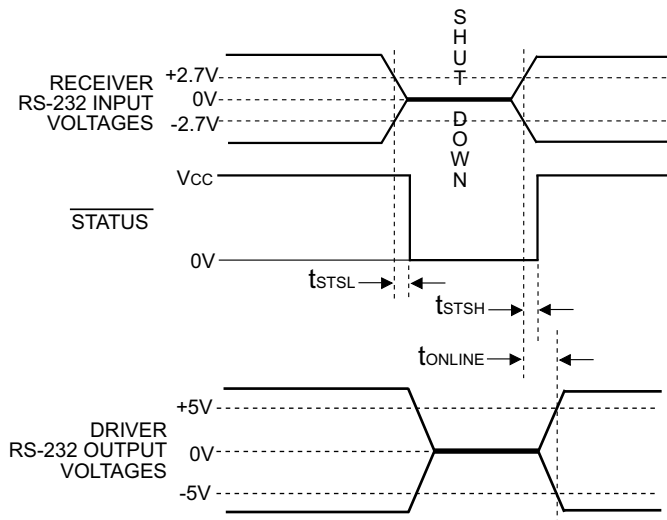


by the  $\overline{\text{ONLINE}}$  pin. When this pin is tied to a logic LOW, the AUTO-ONLINE® function is active. Once active, the device is enabled until there is no activity on the receiver inputs. The receiver input typically sees at least  $\pm 3\text{V}$ , which is generated from the transmitters at the other end of the cable with a  $\pm 5\text{V}$  minimum.

When the external transmitters are disabled or the cable is disconnected, the receiver inputs will be pulled down by their internal  $5\text{k}\Omega$  resistors to ground. When this occurs over a period of time, the internal transmitters will be disabled and the device goes into a shutdown or standby mode. When  $\overline{\text{ONLINE}}$  is HIGH, the AUTO-ONLINE® mode is disabled.

The AUTO-ONLINE® circuit has two stages:

1. Inactive Detection
2. Accumulated Delay



**Figure 17: AUTO-ONLINE® Timing Waveforms**

The first stage, shown in Figure 21, detects an inactive input. A logic HIGH is asserted on  $R_X\text{INACT}$  if the cable is disconnected or the external transmitters are disabled. Otherwise,  $R_X\text{INACT}$  will be at a logic LOW. This circuit is duplicated for each of the other receivers.

The second stage of the AUTO-ONLINE® circuitry, shown in Figure 22, processes all the receiver's  $R_X\text{INACT}$  signals with an accumulated delay that disables the device to less than  $0.8\mu\text{A}$  supply current.

The  $\overline{\text{STATUS}}$  pin goes to a logic LOW when the cable is disconnected, the external transmitters are disabled, or the  $\overline{\text{SHUTDOWN}}$  pin is invoked. The typical accumulated delay is around  $20\mu\text{s}$ .

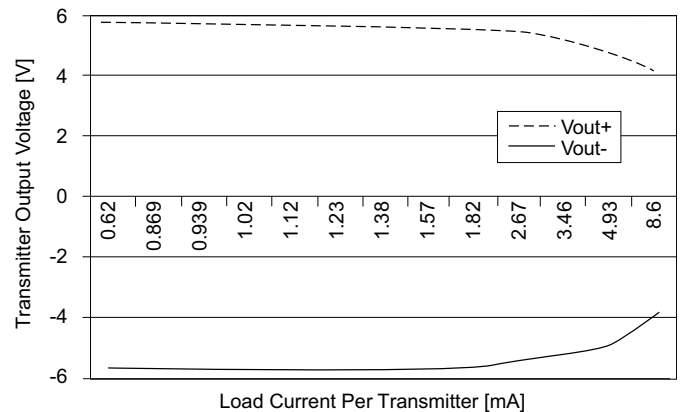
When the MxL83947 drivers or internal charge pump are disabled, the supply current is reduced to less than  $0.8\mu\text{A}$ . This can commonly occur in hand-held or portable applications where the RS-232 cable is disconnected or the RS-232 drivers of the connected peripheral are turned off.

The AUTO-ONLINE® mode can be disabled by the  $\overline{\text{SHUTDOWN}}$  pin. If this pin is a logic LOW, the AUTO-ONLINE® function will not operate regardless of the logic state of the  $\overline{\text{ONLINE}}$  pin. Table 8 summarizes the logic of the AUTO-ONLINE® operating modes. The truth table logic of the MxL83947 driver and receiver outputs can be found in Table 6.

The  $\overline{\text{STATUS}}$  pin outputs a logic LOW signal if the device is shutdown. This pin goes to a logic HIGH when the external transmitters are enabled and the cable is connected.

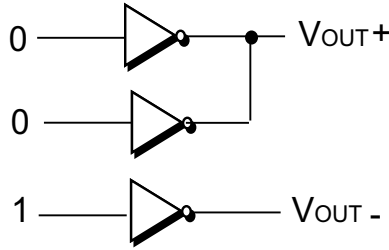
When the MxL83947 device is shut down, the charge pumps are turned off.  $V^+$  charge pump output decays to  $V_{CC}$ , the  $V^-$  output decays to GND. The decay time will depend on the size of capacitors used for the charge pump. Once in shutdown, the time required to exit the shut down state and have valid  $V^+$  and  $V^-$  levels is typically  $200\mu\text{s}$ .

For easy programming, the  $\overline{\text{STATUS}}$  can be used to indicate DSR or a Ring Indicator signal. Tying  $\overline{\text{ONLINE}}$  and  $\overline{\text{SHUTDOWN}}$  together will bypass the AUTO-ONLINE® circuitry so this connection acts like a shutdown input pin.

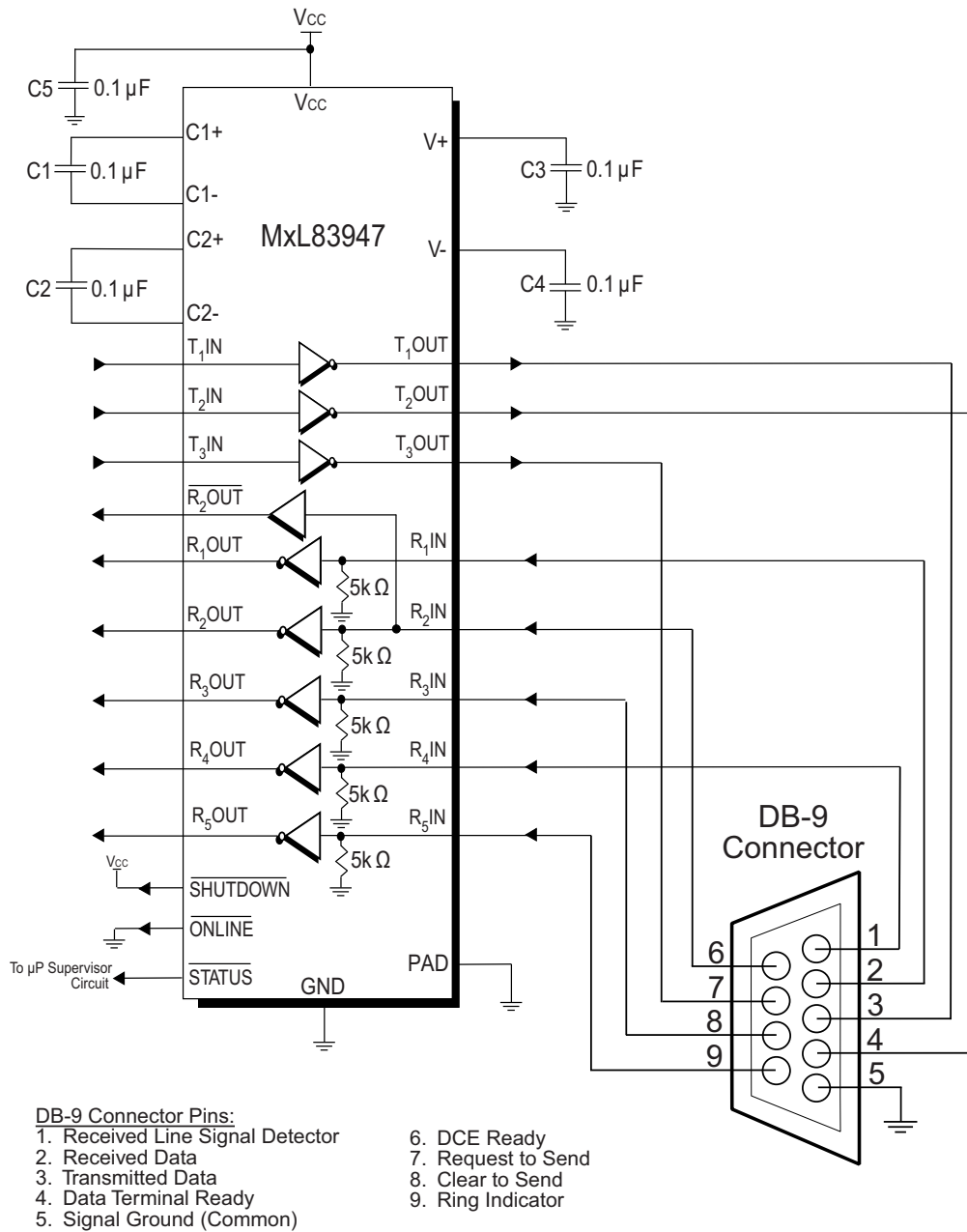


**Figure 18: MxL83947 Driver Output Voltages vs. Load Current per Transmitter**

The MxL83947 driver outputs are able to maintain voltage under loading of up to  $2.5\text{mA}$  per driver, ensuring sufficient output for mouse-driving applications.



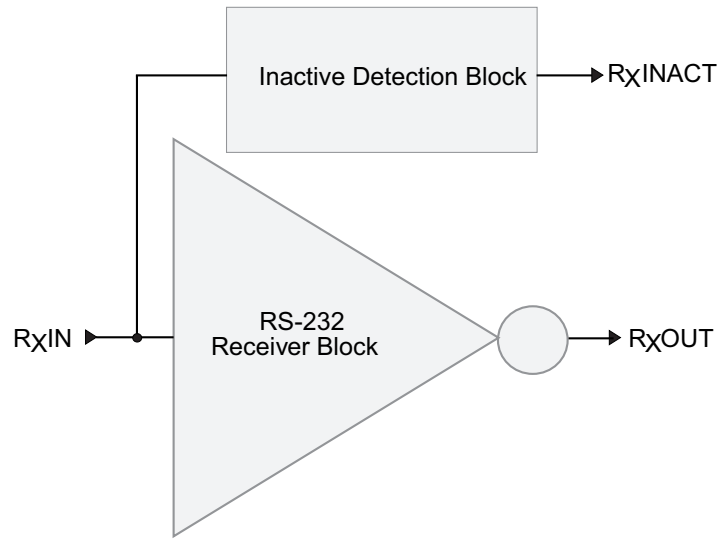
**Figure 19: Mouse Drive Application**



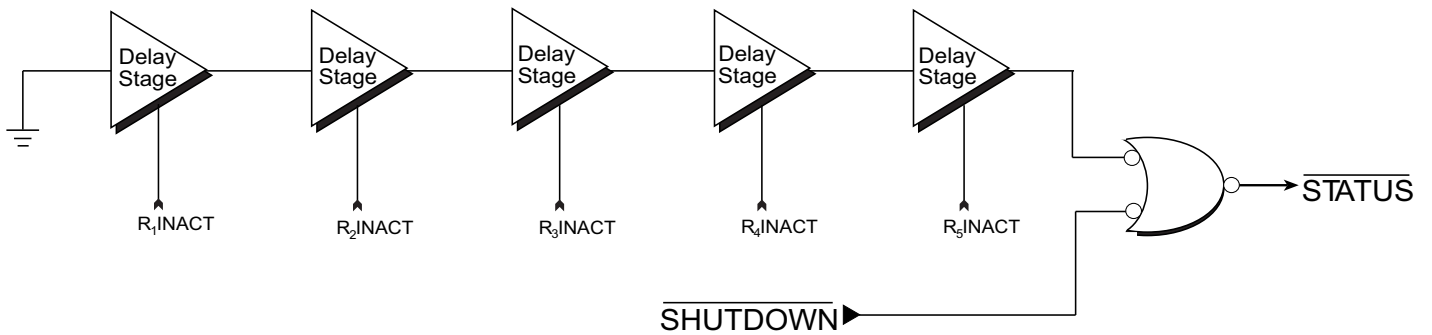
**Figure 20: Attaching MxL83947 to a DB-9 Connector**

**Table 8: AUTO-ONLINE® Logic**

| RS-232 Signal at Receiver Input | $\overline{\text{SHUTDOWN}}$ Input | $\overline{\text{ONLINE}}$ Input | $\overline{\text{STATUS}}$ Output | Transceiver Status              |
|---------------------------------|------------------------------------|----------------------------------|-----------------------------------|---------------------------------|
| Yes                             | High                               | Low                              | High                              | Normal operation (AUTO-ONLINE®) |
| No                              | High                               | High                             | Low                               | Normal operation                |
| No                              | High                               | Low                              | Low                               | Shutdown (AUTO-ONLINE®)         |
| Yes                             | Low                                | High/Low                         | High                              | Shutdown                        |
| No                              | Low                                | High/Low                         | Low                               | Shutdown                        |



**Figure 21: Stage I of AUTO-ONLINE® Circuitry**



**Figure 22: Stage II of AUTO-ONLINE® Circuitry**

## ESD Tolerance

The MxL83947 device incorporates ruggedized ESD cells on all driver output and receiver input pins. The ESD structure is improved over our previous family for more rugged applications and environments sensitive to electro-static discharges and associated transients. The improved ESD tolerance is at least  $\pm 15\text{kV}$  without damage nor latch-up.

There are different methods of ESD testing applied:

- a. MIL-STD-883, Method 3015.7
- b. IEC61000-4-2 Air-Discharge
- c. IEC61000-4-2 Direct Contact

The Human Body Model has been the generally accepted ESD testing method for semiconductors. This method is also specified in MIL-STD-883, Method 3015.7 for ESD testing. The premise of this ESD test is to simulate the human body's potential to store electro-static energy and discharge it to an integrated circuit. The simulation is performed by using a test model as shown in [Figure 23](#). This method will test the IC's capability to withstand an ESD transient during normal handling such as in manufacturing areas where the ICs tend to be handled frequently.

The IEC-61000-4-2, formerly IEC801-2, is generally used for testing ESD on equipment and systems. For system manufacturers, they must guarantee a certain amount of ESD protection since the system itself is exposed to the outside environment and human presence. The premise with IEC61000-4-2 is that the system is required to withstand an amount of static electricity when ESD is applied to points and surfaces of the equipment that are accessible to personnel during normal usage. The transceiver IC receives most of the ESD current when the ESD source is applied to the connector pins. The test circuit for IEC61000-4-2 is shown on [Figure 24](#). There are two methods within IEC61000-4-2, the Air Discharge method and the Contact Discharge method.

With the Air Discharge Method, an ESD voltage is applied to the equipment under test (EUT) through air. This simulates an electrically charged person ready to connect a cable onto the rear of the system only to find an unpleasant zap just before the person touches the back panel. The high energy potential on the person discharges through an arcing path to the rear panel of the system before he or she even touches the system. This energy, whether discharged directly or through air, is predominantly a function of the discharge current rather than the discharge voltage. Variables with an air discharge such as approach speed of

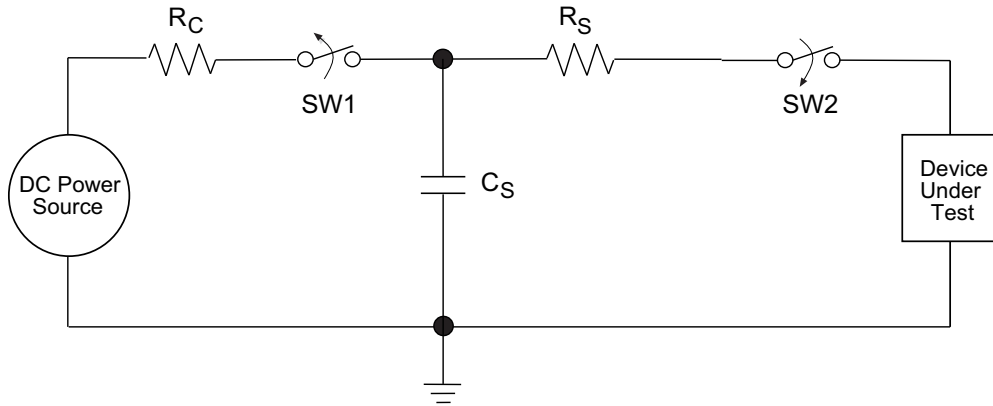
the object carrying the ESD potential to the system and humidity will tend to change the discharge current. For example, the rise time of the discharge current varies with the approach speed.

The Contact Discharge Method applies the ESD current directly to the EUT. This method was devised to reduce the unpredictability of the ESD arc. The discharge current rise time is constant since the energy is directly transferred without the air-gap arc. In situations such as hand held systems, the ESD charge can be directly discharged to the equipment from a person already holding the equipment. The current is transferred on to the keypad or the serial port of the equipment directly and then travels through the PCB and finally to the IC.

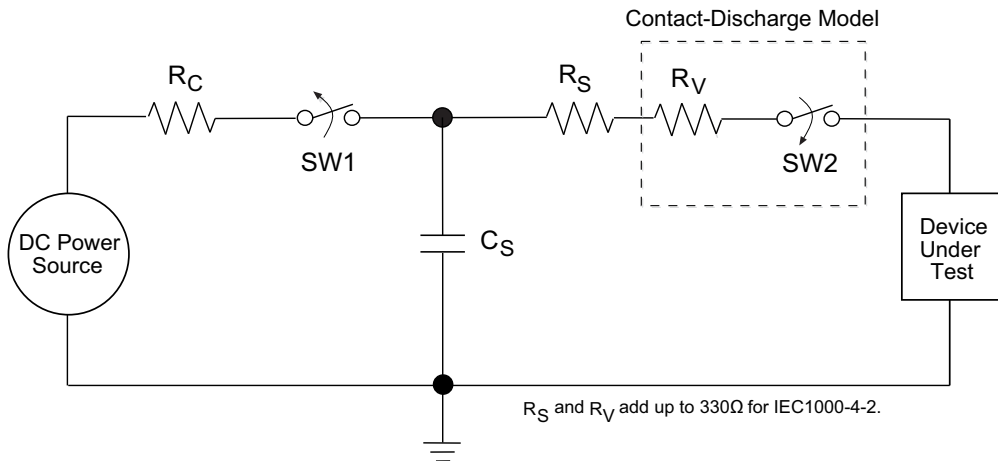
The circuit models in [Figure 23](#) and [Figure 24](#) represent the typical ESD testing circuit used for all three methods. The  $C_S$  is initially charged with the DC power supply when the first switch (SW1) is on. Now that the capacitor is charged, the second switch (SW2) is on while SW1 switches off. The voltage stored in the capacitor is then applied through  $R_S$ , the current limiting resistor, onto the device under test (DUT). In ESD tests, the SW2 switch is pulsed so that the device under test receives a duration of voltage.

For the Human Body Model, the current limiting resistor ( $R_S$ ) and the source capacitor ( $C_S$ ) are  $1.5\text{k}\Omega$  and  $100\text{pF}$ , respectively. For IEC-61000-4-2, the current limiting resistor ( $R_S$ ) and the source capacitor ( $C_S$ ) are  $330\Omega$  and  $150\text{pF}$ , respectively.

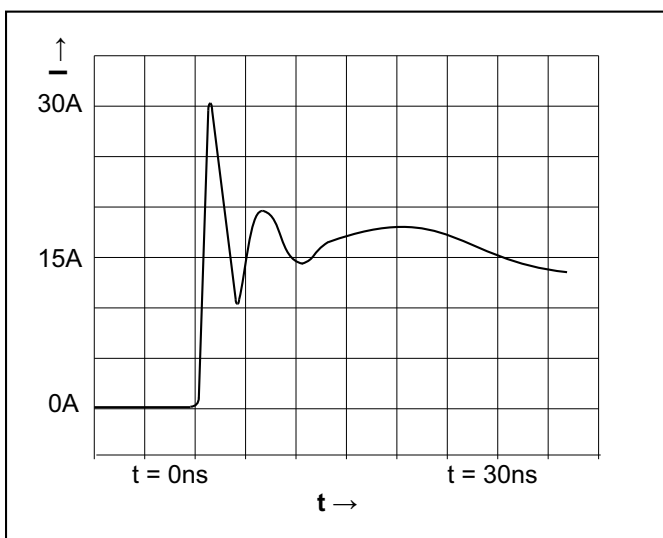
The higher  $C_S$  value and lower  $R_S$  value in the IEC61000-4-2 model are more stringent than the Human Body Model. The larger storage capacitor injects a higher voltage to the test point when SW2 is switched on. The lower current limiting resistor increases the current charge onto the test point.



**Figure 23: ESD Test Circuit for Human Body Model**



**Figure 24: ESD Test Circuit for IEC61000-4-2**



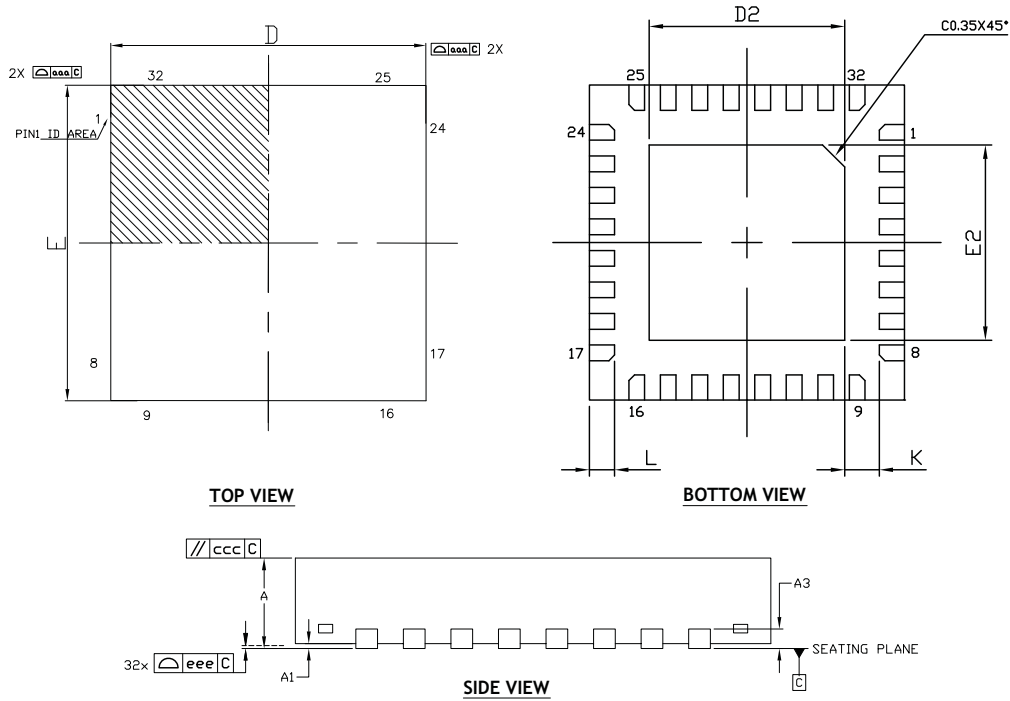
**Figure 25: ESD Test Waveform for IEC61000-4-2**

**Table 9: Transceiver ESD Tolerance Levels**

| Device Pin Tested | Human Body Model  | IEC 61000-4-2     |                  |       |
|-------------------|-------------------|-------------------|------------------|-------|
|                   |                   | Air Discharge     | Direct Contact   | Level |
| Driver outputs    | $\pm 15\text{kV}$ | $\pm 15\text{kV}$ | $\pm 8\text{kV}$ | 4     |
| Receiver inputs   | $\pm 15\text{kV}$ | $\pm 15\text{kV}$ | $\pm 8\text{kV}$ | 4     |

# Mechanical Dimensions

## QFN32



| DIM SYMBOL | MIN      | NOM     | MAX  |
|------------|----------|---------|------|
| A          | 0.80     | 0.90    | 1.00 |
| A1         | 0.00     | 0.02    | 0.05 |
| A3         | ---      | 0.20Ref | ---  |
| b          | 0.18     | 0.25    | 0.30 |
| D          | 5.00 BSC |         |      |
| E          | 5.00 BSC |         |      |
| e          | 0.50 BSC |         |      |
| D2         | 3.00     | 3.10    | 3.20 |
| E2         | 3.00     | 3.10    | 3.20 |
| L          | 0.35     | 0.40    | 0.45 |
| K          | 0.20     | -       | -    |
| aaa        |          | 0.15    |      |
| bbb        |          | 0.10    |      |
| ccc        |          | 0.10    |      |
| ddd        |          | 0.05    |      |
| eee        |          | 0.08    |      |
| fff        |          | 0.10    |      |
| N          |          | 32      |      |

**TERMINAL DETAILS**

- ALL DIMENSIONS ARE IN MILLIMETERS, ANGLES ARE IN DEGREES.
- DIMENSIONS AND TOLERANCE PER JEDEC MO-220.

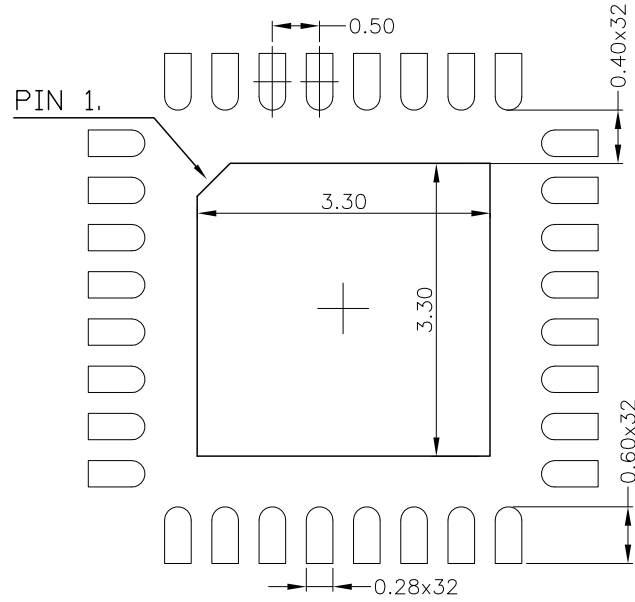
Drawing No.: POD-00000036

Revision: B

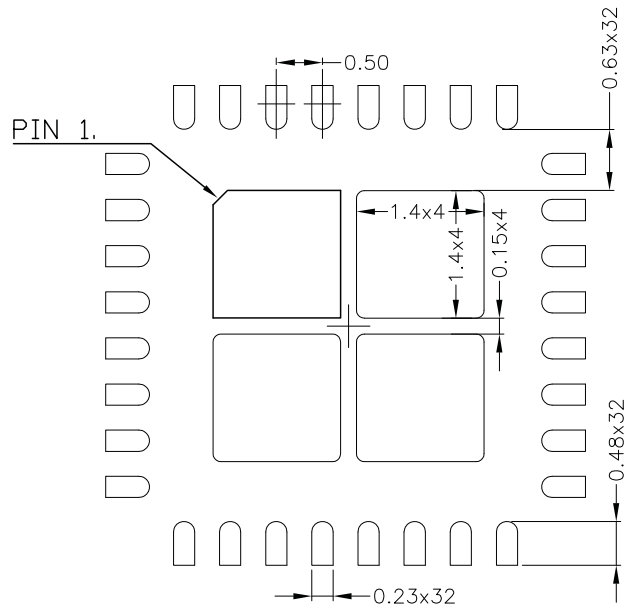
**Figure 26: Mechanical Dimensions, QFN32**

# Recommended Land Pattern and Stencil

## QFN32



**TYPICAL RECOMMENDED LAND PATTERN**



**TYPICAL RECOMMENDED STENCIL**

Drawing No.: POD-00000036

Revision: B

**Figure 27: Recommended Land Pattern and Stencil, QFN32**