

# N-15

## Low Profile Rotary Position Sensor / Potentiometer

The N-15 series offers you endless rotation, 340° wide electrical angle, SMD or through-hole mount, an extended working temperature range of -40°C to +120°C and a whole series of customisation possibilities making it the most flexible product on the market. The N-15 is ideal for appliance and automotive control and sensor applications.

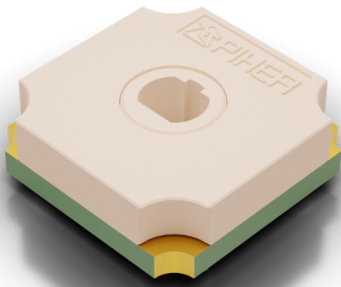

### KEY FEATURES

- ▶ SMD or Through-hole mount
- ▶ Excellent performance (3% linearity)
- ▶ Up to 2.000.000 life cycles
- ▶ IP54 protection
- ▶ 360° endless rotation
- ▶ 340° electrical angle
- ▶ Low profile (4.4 mm) and footprint (15 mm)
- ▶ High operating temperature range
- ▶ Polarised "T" rotor (European Home Appliance standard)
- ▶ Embossed tape packaging according to IEC 60286-3:2007
- ▶ All PT-15 shafts compatible

Also available as 6-pulse incremental encoder or mechanical switch with up to 12 positions.

### ELECTRICAL SPECIFICATIONS

	Standard	Extra-long life
Taper	Linear	
Resistance range <sup>1</sup>	5 kΩ ≤ R <sub>n</sub> ≤ 100 kΩ	5 kΩ
Tolerance	±30%	
Max. voltage	120 Vdc	27 Vdc
Nominal power at 50°C (122°F)	0.15 W	
Linearity (absolute)	3%	
Operating temperature	-40°C to +120°C	

<sup>1</sup> Others check availability

### MECHANICAL SPECIFICATIONS

	Standard	Extra-long life
Mechanical rotation angle	360°	
Electrical rotation angle	340° ±10°	110° ±10°
Rotational torque	≤20 mN.m	
Mounting method	SMD or Through-hole	SMD
Mechanical life	Up to 200,000 cycles	Up to 2,000,000 cycles

### APPLICATIONS

#### Appliances

- ▶ Timer and program selection
- ▶ Temperature controls

#### Automotive

- ▶ HVAC control
- ▶ Seat position
- ▶ Mirror actuator feedback
- ▶ Gear Shift Position

#### Size and position detectors

# N-15

## Low Profile Rotary Position Sensor / Potentiometer

### ENVIRONMENTAL TESTING

	Test method	$\Delta R$ [%]- typical test results
Electrical life	1.000 h at 50°C; 0.15 W	$\pm 40\%$
Mechanical life	100,000 cycles at 20 cpm	$\pm 40\%$ (Rn < 100 k)
Temperature coefficient	-40°C; +120°C	$\pm 300$ ppm/°C (Rn < 100 k)
Thermal cycling	10h at 120°C and 10h at -40°C	$\pm 40\%$
Damp heat	480h at 40°C and 95% relative humidity (RH)	$\pm 40\%$
Storage	6 month at 23°C $\pm 2^\circ\text{C}$ and 50% RH	$\pm 40\%$

Out of range values may not comply with these results. Standard test conditions: temperature: 23°C  $\pm 2^\circ\text{C}$  and 45% to 70% RH

### RECOMMENDED CONNECTIONS

Recommended connection circuit for a position sensor or control application (voltage divider circuit electronic design).

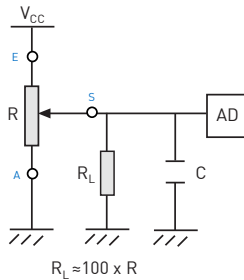

### POWER RATING CURVE

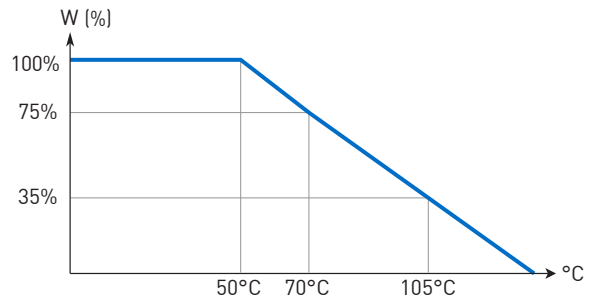

### RECOMMENDED REFLOW PROFILE

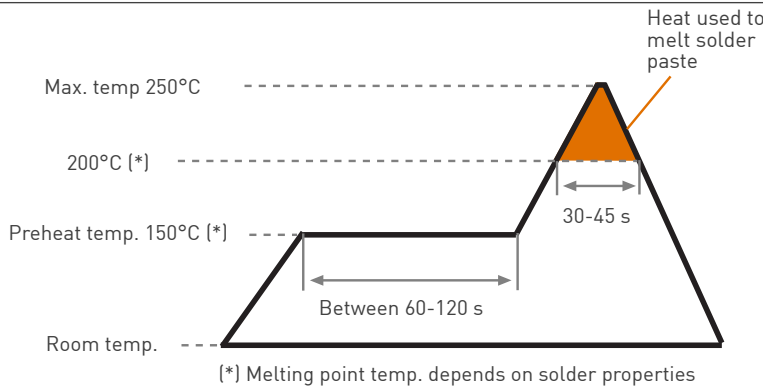

The recommended reflow profile is provided as a guideline. Optimal profile may differ due to oven type, assembly layout or other design or process variables. Customers should verify actual device performance in their specific application and reflow process. Please contact Piher if you require additional support.

# N-15

## Low Profile Rotary Position Sensor / Potentiometer

### HOW TO ORDER

#### Standard version

N15	T	-	- - - -	A	3030	Optional features - -
Series	Rotor T	Mounting method <sup>1</sup> S = SMD V = Through-hole H = Horizontal adjust	Ω-Value <sup>2</sup> 502 = 5 kΩ ... 104 = 100 kΩ	Taper <sup>3</sup> A = lin.	Tolerance <sup>4</sup> 3030 = ±30%	Life [empty] = 100k cycles U = 200k cycles

#### Long-life version

Z15	T	S	- 502	A	3030
Series	Rotor T	Mounting method <sup>1</sup> S = SMD	Ω-Value 502 = 5 kΩ	Taper <sup>3</sup> A = lin.	Tolerance <sup>4</sup> 3030 = ±30%

1. Mounting method: Horizontal adjust versions will be studied case by case.
  2. Ω- Value: XX - First two digits of Ω-value; XXX - Number of zeros
  3. A wide range of custom tapers and step curves is available on request.
  4. Other tolerances and optional precision laser-trimmed voltage divider calibration available.
- For Switch (S-15) and Incremental Encoder (E-15) versions see below or contact Piher Sensing Systems.

### STANDARD RESISTANCE-VALUES

Resistance Ω	5k	10k	20k	22k	25k	47k	50k	100k
Order Code	502	103	203	223	253	473	503	104

### DIMENSIONS

#### SMD mount

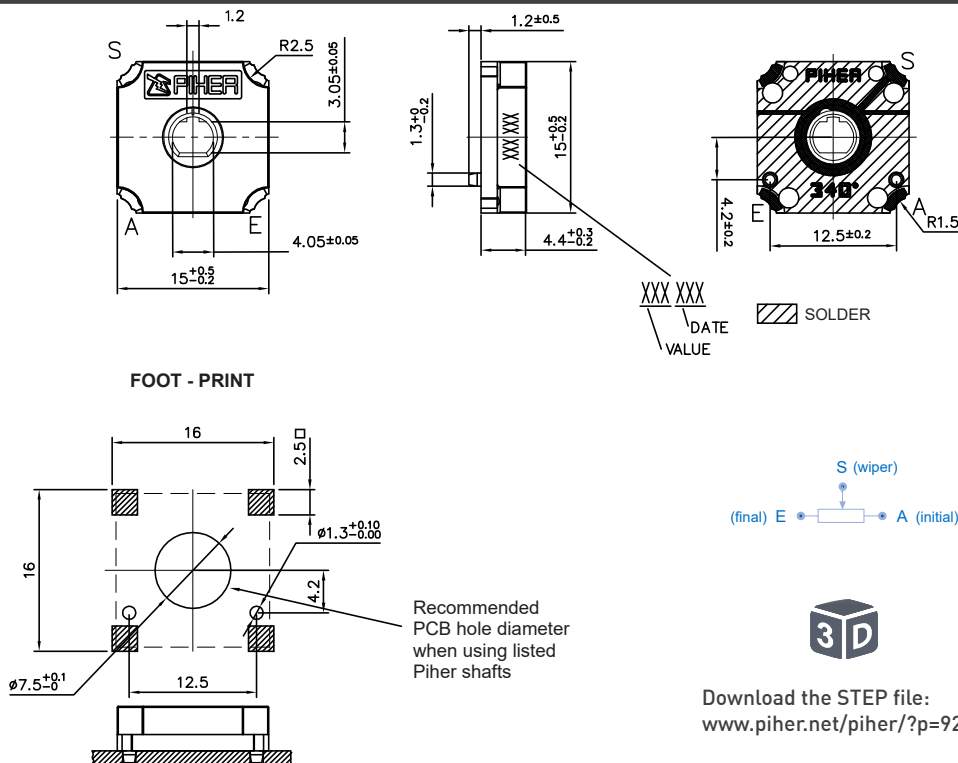

Download the STEP file:  
[www.piher.net/piher/?p=924](http://www.piher.net/piher/?p=924)

# N-15

## Low Profile Rotary Position Sensor / Potentiometer

### DIMENSIONS

#### Through-hole mount

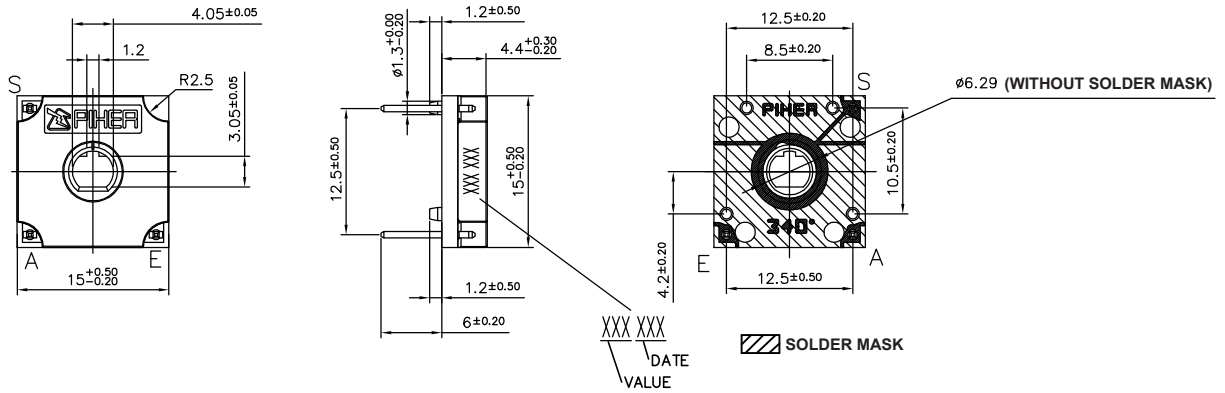

PCB HOLE LAYOUT 1

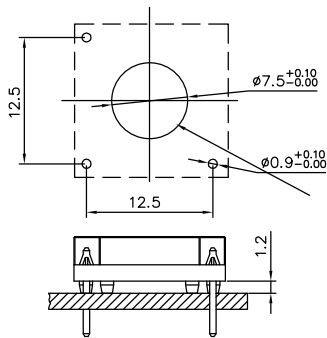

PCB HOLE LAYOUT 2

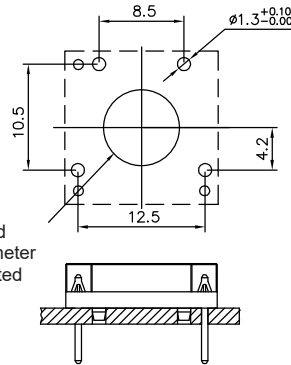

Recommended PCB hole diameter when using listed Piher shafts

#### Horizontal adjust - vertical mount

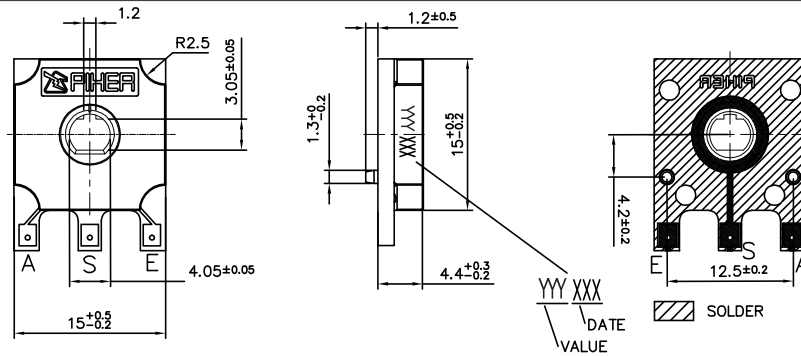

#### STANDARD WIPER POSITION

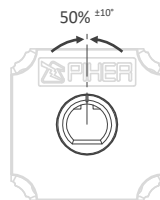

# N-15

## Rotary Switch (S-15) and Incremental Encoder (E-15)

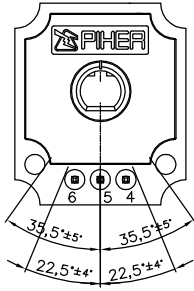
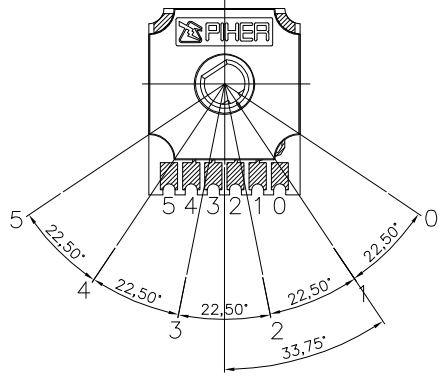
ROTARY SWITCH S-15		
Standard specifications	2-position switch	6-position switch
Switch Positions		
Closed contact resistance	< 5 Ω	
Open contact resistance	> 10 mΩ	
Contact current	10μA - 100mA	
Operating voltage	13.5 ±0.2 Vdc	16 Vdc
Temperature range	-40°C to +85°C	
Rotational torque	< 2 Ncm	
Mechanical rotational angle	360° (endless rotation)	
Mechanical life	15K cycles	35K cycles

For more information on switch sequence, dimensions, packaging or ordering code, please contact Piher Sensing Systems.

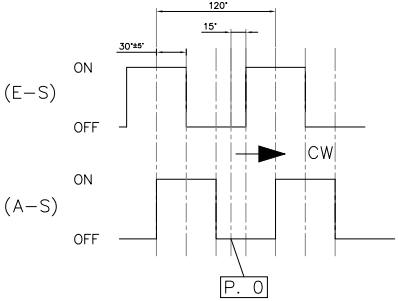
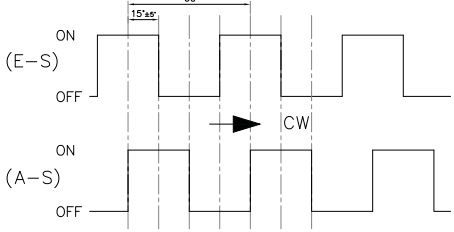
INCREMENTAL ENCODER E-15		
Standard specifications	3-pulse encoder	6-pulse encoder
Graph Code		
Closed contact resistance	< 5 Ω	
Open contact resistance	> 10 mΩ	
Contact current	10μA - 100mA	
Operating voltage	13.5 ±0.2 Vdc	16 Vdc
Temperature range	-40°C to +120°C	
Rotational torque	< 2 Ncm	
Mechanical rotational angle	360° (endless rotation)	
Mechanical life	10K cycles	36K cycles

For more information on packaging options or ordering code, please contact Piher Sensing Systems.

# N-15

## Low Profile Rotary Position Sensor / Potentiometer

### SHAFTS

#### Hollow shafts models

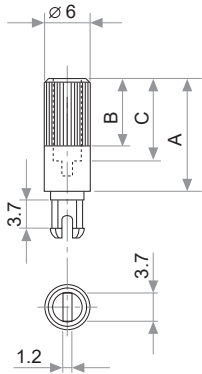

Fig.	Ref.	A	B	C
1	5272	12	9	8
2	5214	19	9	15
5	5208	9.5	6.5	5.5
9	5216	35	9	31
10	5218	37.8	9	33.8
11	5209	35	25	31

A = Length measured from rotor surface  
 B = Knurling length  
 C = Hollow depth

#### Solid shafts models

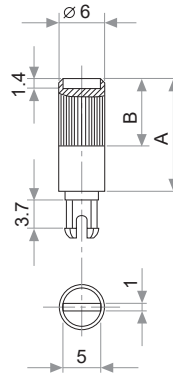

Fig.	Ref.	A	B
6	5219	15	9
7	5220	16.8	9
8	5207	25.3	9
12	5227	46	5

Slot [1 x 1.4] perpendicular to wiper position.  
 Fig. 12 slot is on line with wiper position.

Fig. 3 - Ref. 5372	Fig. 15 - Ref. 5217	Fig. 17 - Ref. 5210	Fig. 18 - Ref. 5271	Fig. 19 - Ref. 6032*	Fig. 20 - Ref. 5369*
Fig. 21 - Ref. 6031*	Fig. 22 - Ref. 6029	Fig. 23 - Ref. 6022	Fig. 29 - Ref. 6162	Fig. 25 - Ref. 6059	Fig. 27 - Ref. 5268*
Fig. 28 - Ref. 6055	<p>Shafts must be ordered separately and are delivered unassembled.                      *Not available in self-extinguishable plastic.</p>				