



FEATURES

- Conceived and designed for easy customisation.
- SMD or Through-hole Mount.
- Endless Rotation (360°).
- Wide Electrical Angle (340° ± 10°).
- Extended Mechanical Life (100k cycles).
- Working Temperature Range (-40°C to +120°C).
- Low Profile (4.4 mm).
- Linearity: ± 3% (default).
- Embossed Tape or Bulk packaging.
- Reflow Soldering capability.
- Shaft insertable from both sides.
- Polarised "T" rotor (European Home Appliance standard).
- All PT/ PTC 15 shafts compatible.
- IP54 protection according to IEC 60529.

STANDARD SPECIFICATIONS

Resistance values*:	5k to 100k
Tolerance:	± 30%
Nominal Power:	0.15 W @ 50°C
Linearity (absolute):	± 3%
Taper:	Linear
Mechanical Life**:	100K cycles
Temperature Range:	-40°C to +120°C
Mechanical Angle:	360°
Electrical Angle:	340° ± 10°
Rotational Torque:	≤ 20 mN.m
Max. Voltage:	250 VDC

* Others: check availability

** 200K cycles version available check availability. For higher mechanical life see the Z15 product with 2M cycles.

TYPICAL APPLICATIONS

The N15 series offers an SMD and Through Hole mount solution for the majority of Position/Rotary Sensor and multi-purpose Control applications such as:

- Automotive HVAC, Seat, Rear-view mirror actuator feedback sensors and HVAC Controls
- Temperature Control for Boilers, Wall Heaters, Showers, Radiators, Conventional and Microwave Ovens, Freezers...
- Timer & Function/Programme Select for Washing Machines, Dishwashers and all White Goods in general.
- Size and Position detectors

HOW TO ORDER

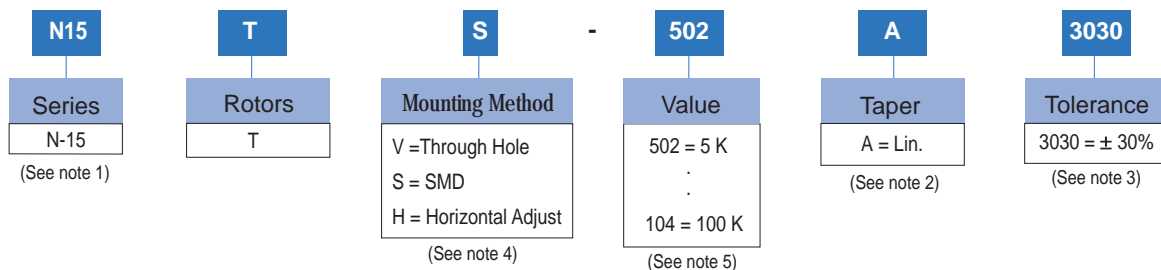

NOTES:

- (1) A wide variety of custom substrates available
- (2) Availability of a wide range of customised tapers and step curves
- (3) Others: check availability. Optional precision laser-trimmed voltage divider calibration
- (4) Horizontal adjust versions will be studied case by case
- (5) Value Example: Code: 50 2 5K Ω
 ↳ Numb of zeros
 ↳ First two digits of the value.

Shafts are not available mounted to the potentiometer and should be ordered separately

NOTE: The information contained here should be used for reference purposes only.

Wiper positioned at 50 % of the electrical angle.

N-15 T S + DRAWING NUMBER (Max. 16 digits)

This way of ordering should be used for options which are not included in the "How to order" standard and optional extras.

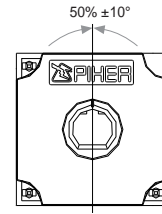

SMD MOUNT

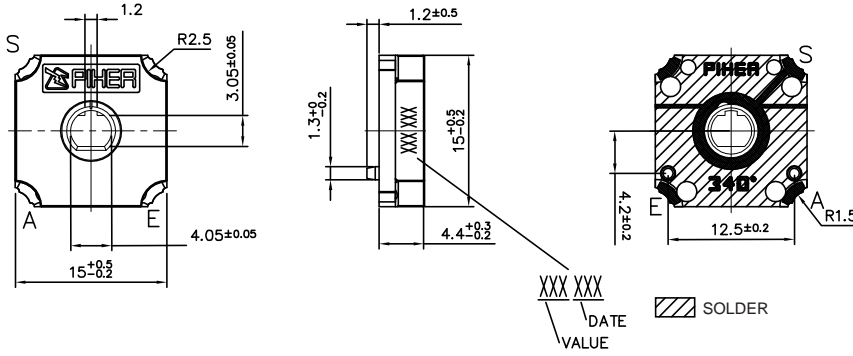

FOOT - PRINT

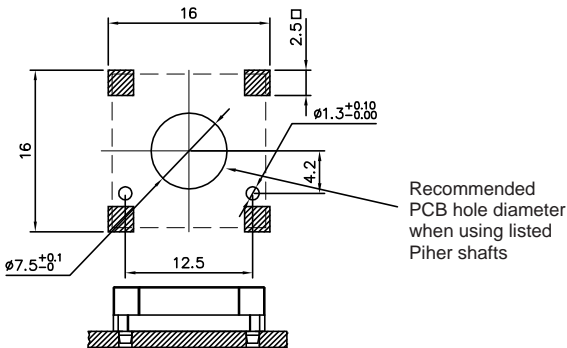

Download the STEP file here:
<https://piher.net/piher/?p=924>

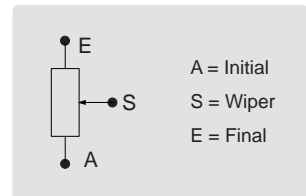

THROUGH HOLE MOUNT

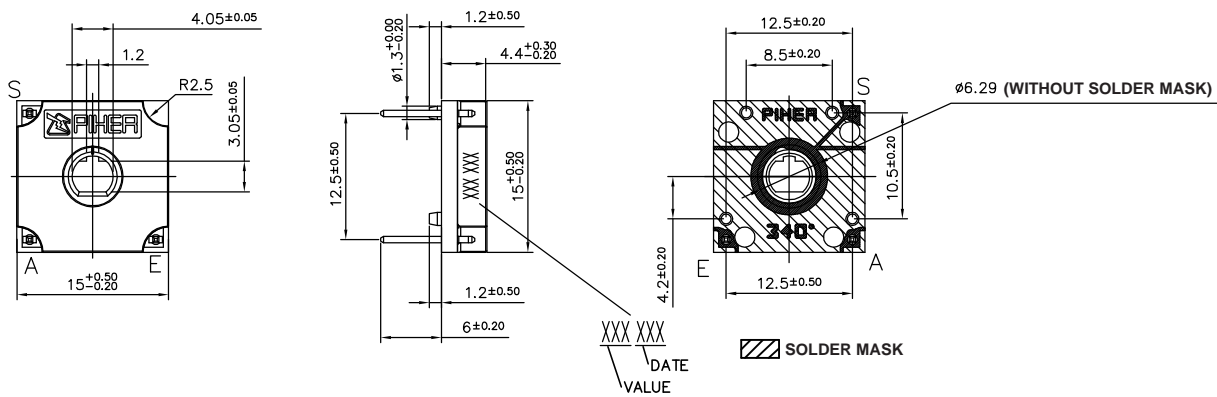

PCB HOLE LAYOUT 1

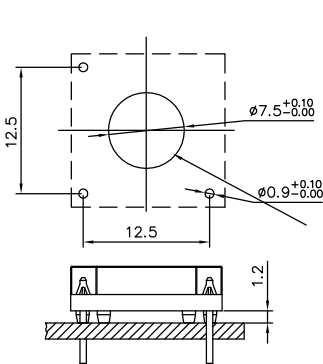

PCB HOLE LAYOUT 2

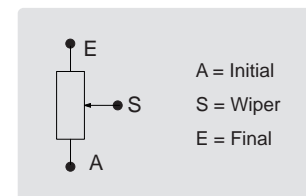
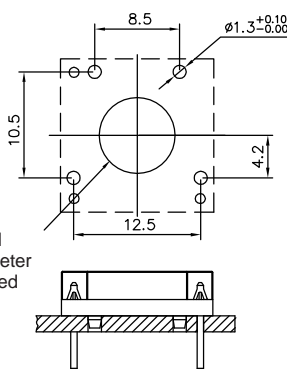

HORIZONTAL ADJUST - VERTICAL MOUNT

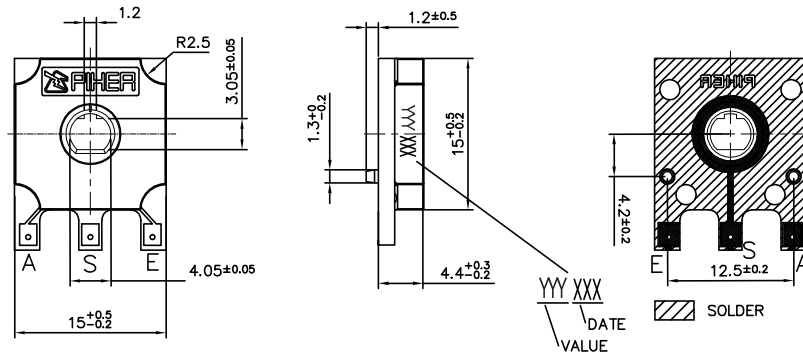

TESTS

TYPICAL VARIATIONS

ELECTRICAL LIFE	1.000 h. @ 50°C; 0.15 W	± 40 %
MECHANICAL LIFE (CYCLES)	100,000 @ 20 CPM	± 40 % (Rn < 100 K)
TEMPERATURE COEFFICIENT	-40°C to +120°C	±300 ppm (Rn < 100 K)
THERMAL CYCLING	10h. @ 120°C; 10h. @ -40°C	± 40 %
DAMP HEAT	500 h. @ 40°C @ 95% HR	± 40 %

NOTE : Out of range values may not comply these results.

PACKAGING

BULK

150 Units per box.
This is the default packaging for through-hole models.

If you want SMD models to be delivered with bulk packaging please contact Piher before ordering.

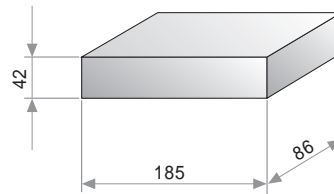

EMBOSSSED TAPE

500 Units per reel.
For SMD models only.

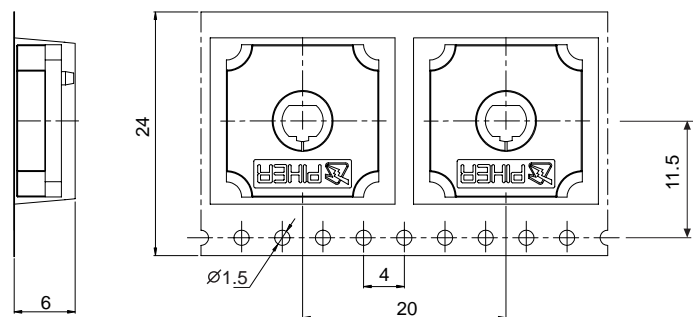
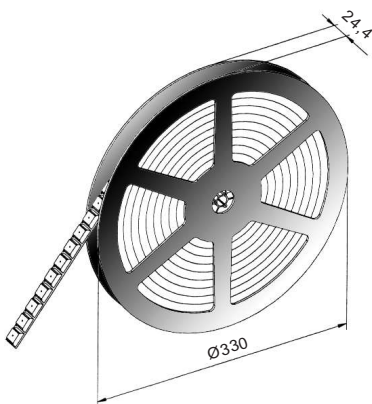

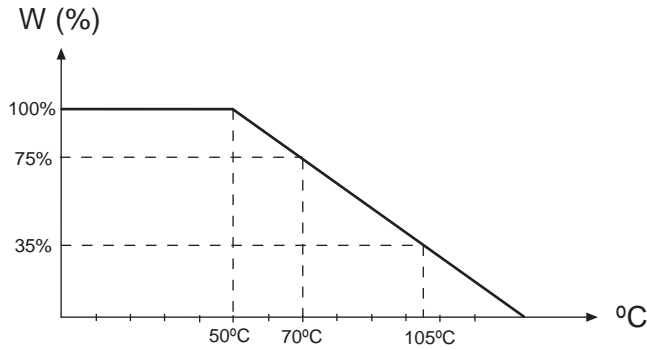

Recommended connection scheme for Piher's position sensors (voltage divider)

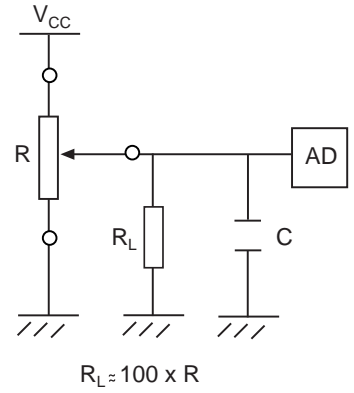

RECOMMENDED REFLOW PROFILE

SMD Types

SnPb Reflow Profile

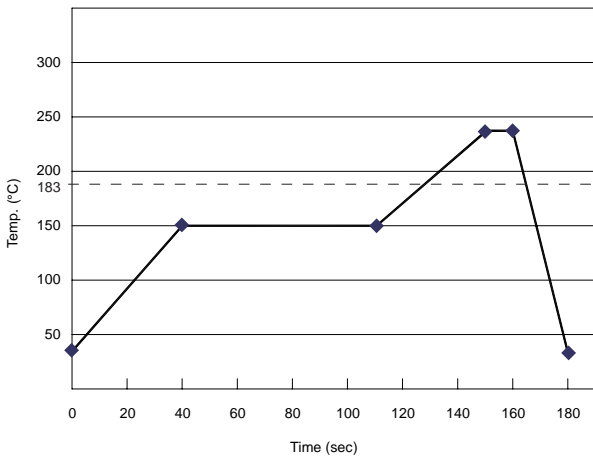

Lead Free Reflow Profile

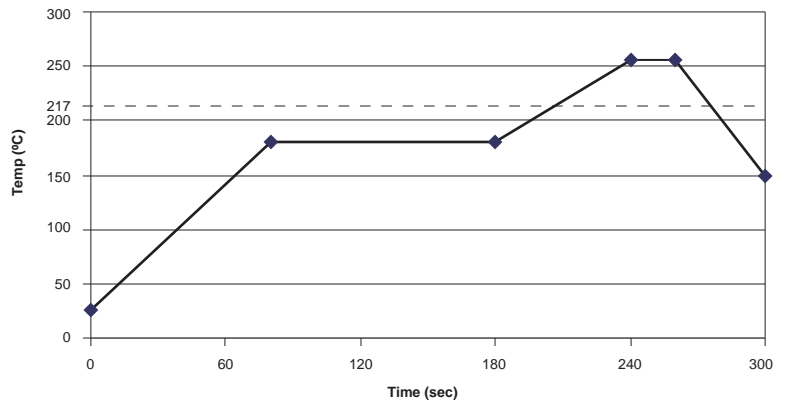

The recommended reflow profile is provided as a guideline. Optimal profile may differ due to oven type, assembly layout or other design or process variables. Customers should verify actual device performance in their specific application and reflow process. Please contact Piher if you require additional support.

SHAFTS

Hollow model shafts

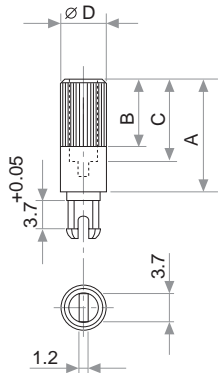

FIG.	A	B	C	D	Ref.
1	12	9	8	6	5272
2	19	9	15	6	5214
5	9.5	6.5	5.5	6	5208
9	35	9	15	6	5216
10	37.8	9	33.8	6	5218
11	35	25	31	6	5209
13	7.8	4.8	3.8	6	5265

Solid model shafts

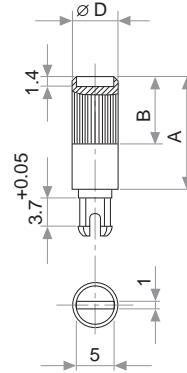

FIG.	A	B	D	Ref.
6	15	9	6	5219
7	16.8	9	6	5220
8	25.3	9	6	5207
12	46	5	6	5227

Slot (1 x 1.4) perpendicular to wiper position. Fig. 12 slot is on line with wiper position.

A = Length (FRS); B=Knurling length; C=Hollow depth; D=Shaft diameter; FRS=From rotor surface