

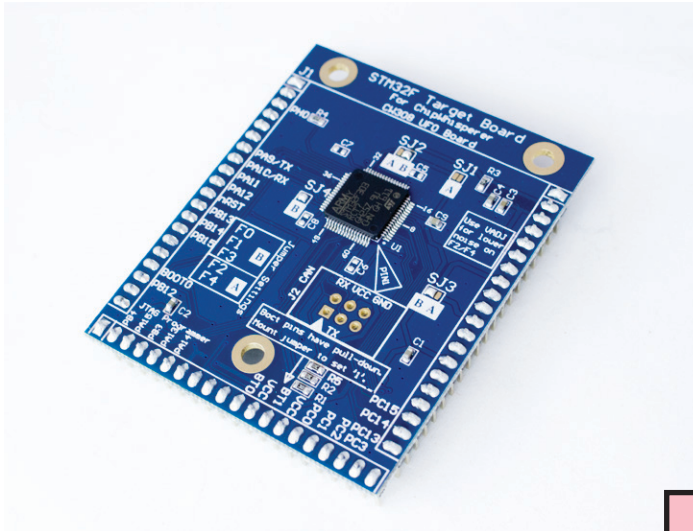

# STM32Fx/STM32Lx UFO Target

NewAE Technology Inc.  
newae.com



The CW308T-STM32F target series allows experiments on the popular STM32F/STM32L series of Arm devices in TQFP-64 package. This includes the STM32F0, STM32F1, STM32F2, STM32F3, STM32F4, STM32L4, and STM32L5. Devices within this family have varying core types, peripheral options, and hardware cryptographic peripheral support.

Devices within this family also have differing support for a data and instruction caches, allowing you to compare code and libraries running on different processor architectures while keeping the same development setup. The ChipWhisperer capture supports programming this series of devices via a serial bootloader.

**CW308 UFO Baseboard Required for use!**

**ST-LINK/V2 Recommended for Debug.**

## Product Highlights

STM32Fx and STM32Lx series in TQFP64 package supported.

Optional CAN header allows connection of CANoodler (only for devices with CAN peripheral).

JTAG header on CW308 baseboard allows use of ST-Link/V2 or other JTAG programmers and debuggers.

Example serial program and HAL library allows use of most ChipWhisperer firmware examples and tutorials directly.

32-bit cores (Arm Cortex) with variety of peripheral options, including multiple security cores.

## Ordering Summary

NewAE Part Number	Series	Target Part Number	HW AES	Flash	SRAM
NAE-CW308T-STM32F0	F0	STM32F071RBT6	No	128KB	16KB
NAE-CW308T-STM32F1	F1	STM32F100RBT6B	No	128KB	8KB
NAE-CW308T-STM32F2HWC	F2	STM32F215RET6	Yes	512KB	132KB
NAE-CW308T-STM32F3	F3	STM32F303RCT7	No	256KB	40KB
NAE-CW308T-STM32F4HWC	F4	STM32F415RGT6	Yes	1MB	192KB
NAE-CW308T-STM32F4	F4	STM32F405RGT6	No	1MB	192KB
NAE-CW308T-STM32L4	L4	STM32L443RCT6	Yes	256KB	64KB
NAE-CW308T-STM32L5HWC	L5	STM32L562RET6	Yes	512KB	256KB

## Product Links

- Full Documentation <https://wiki.newae.com/CW308T-STM32F>
- Firmware Examples <https://github.com/newaetech/chipwhisperer/tree/master/hardware/victims/firmware>
- Design Files <https://github.com/newaetech/chipwhisperer-target-cw308t>

# Schematic

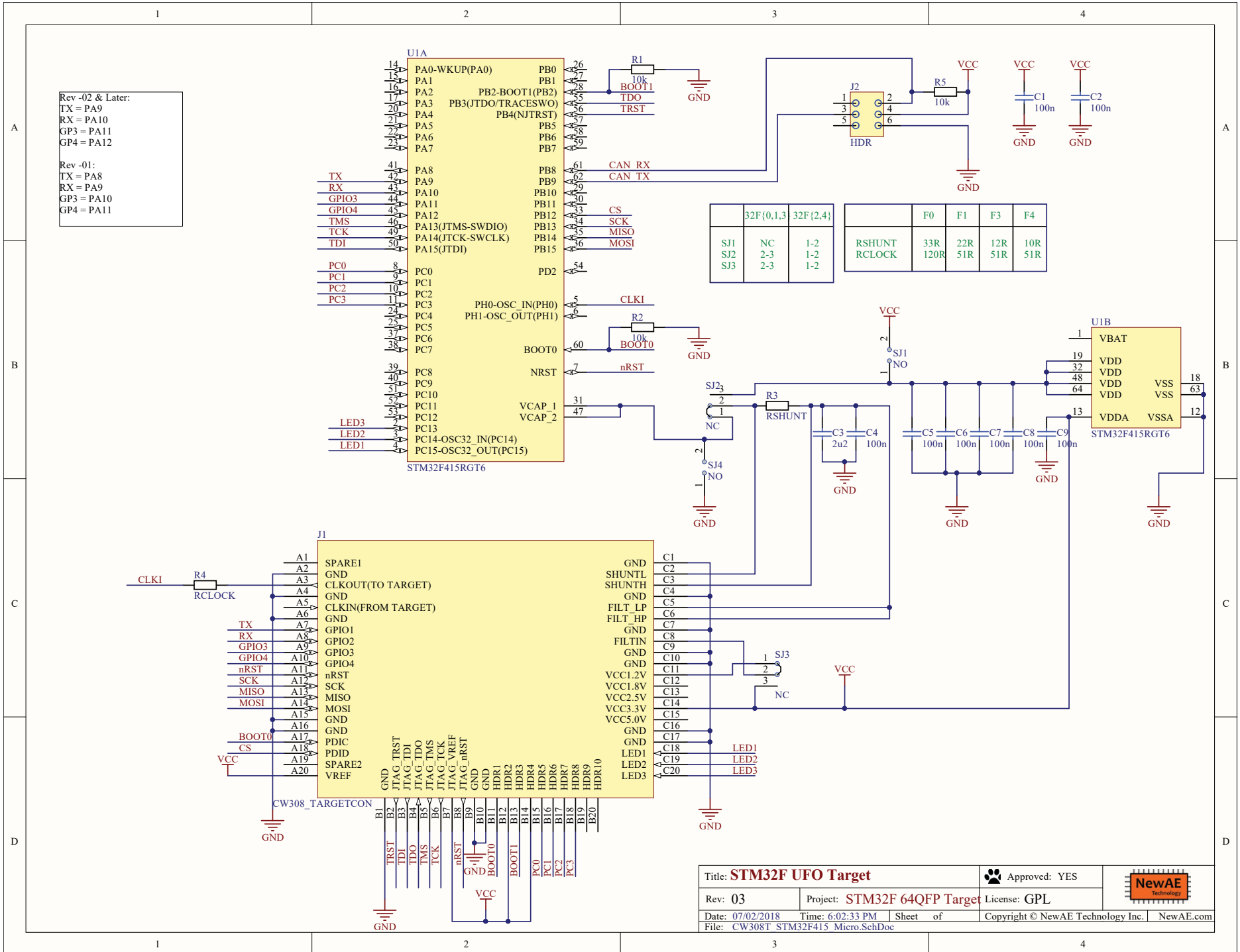

Title: <b>STM32F UFO Target</b>		Approved: YES	
Rev: 03	Project: STM32F 64QFP Target	License: GPL	
Date: 07/02/2018	Time: 6:02:33 PM	Sheet of	Copyright © NewAE Technology Inc. NewAE.com
File: CW308T_STM32F415_Micro.SchDoc			