

PTF FAMILY

Platinum Thin Film (PTF) Temperature Elements

Description

The PTF family combines a group of resistance temperature detectors (RTD) using a Platinum resistor element utilizing the latest in thin film technology. It consists of a structured platinum film on a ceramic substrate, passivated by a glass coating. The connection wires are protected with glass on the welding area.

The characteristic curve of this Platinum RTD complies with DIN EN 60751. The usage of Platinum as the resistive material provides excellent long-term stability.

Due to small size and low mass, this RTD has a fast response time and low time constant; therefore, it is an optimal solution for fast and precise feedback control systems.

Features

- Conforms to DIN EN 60751
- Wide operating temperature range: -50°C to +600°C (Ni/Au wire and Class F 0.3, Ag-Wire versions are limited to 300°C)
- Standard nominal resistances values: R0: 100 and 1000Ω (others available upon request) Class F 0.1 (T = AA), F 0.15 (A), F 0.3 (B) and F 0.6 (C) accuracy
- Very low drift over lifetime
- Fast response time due to low thermal mass
- Variety of outline dimensions available to fit a wide range of space requirements
- Global interchangeability

Applications

- Temperature feedback control
- White goods
- Industrial applications
- Automotive
- Medical
- Sensing element for plug-in probes

CLICK HERE ›
CONNECT WITH A SPECIALIST

PTF TEMPERATURE ELEMENTS

Datasheet

*Operating temperature range is, -200°C to +600°C for elements with Au-coated Ni wire. Max temperature for elements with Ag wire is 300°C. Accuracy is not guaranteed if the sensor is exposed to temperatures outside the specified operating temperature range.

Parameter	Symbol	Condition	Min	Typ	Max	Unit
Nominal Resistance at 0 °C	R ₀	Class B (F0.3) Pt100 Class B (F0.3) Pt1000	99.88 999.8	100.00 1000.0	100.12 1001.2	Ω
Tolerance at 25°C		Room temperature calibration	-0.43	0	0.43	°C
Temperature Coefficient of Resistance	TCR	0 °C, 100 °C		3850		ppm/°C
Tolerance Temperature Range		Class C (F 0.6) Class B (F 0.3) Class A (F 0.15) Class T (F 0.1) Class B/Cryo (F 0.3)	-50 -50 -30 -30 -200		600 600 300 200 200	°C
Self-Heating Coefficient in Air Flow: 1 m/s		PTFC outline PTFD outline PTFF outline PTFM outline		0.5 0.33 0.5 0.5		°C/mW
Response Time Water Flow: 0.4 m/s	τ _{W,0.9}	PTFC outline PTFD outline PTFF outline PTFM outline		0.2 0.35 0.2 0.2		s
Response Time Air Flow: 1 m/s	τ _{A,0.9}	PTFC outline PTFD outline PTFF outline PTFM outline		10 17 10 10		s
Measuring Current R ₀ : 100 Ω		PTFC outline (Class B) PTFD outline (Class B) PTFF outline (Class B) PTFM outline (Class B)			1.4 1.7 1.4 1.4	mA
Measuring Current R ₀ : 1000 Ω		PTFC outline (Class B) PTFD outline (Class B) PTFF outline (Class B) PTFM outline (Class B)			0.4 0.5 0.4 0.4	mA

Calculation Formulas

The calculation formulas of this Pt-RTD are defined in DIN EN 60751 as following:

For T ≥ 0 °C:

$$R_{(T)} = R_{(0)} \cdot (1 + a \cdot T + b \cdot T^2)$$

For T < 0 °C:

$$R_{(T)} = R_{(0)} \cdot [1 + a \cdot T + b \cdot T^2 + c \cdot (T - 100^\circ\text{C}) \cdot T^3]$$

Coefficients:

$$\begin{aligned} a &= 3.9083\text{E-}03 \\ b &= -5.775\text{E-}07 \\ c &= -4.183\text{E-}12 \end{aligned}$$

Tolerances:

Class F 0.1 (T = AA):	± (0.10+0.0017* T/°C) °C	(-30...+200 °C)
Class F 0.15 (A)	± (0.15+0.002* T/°C) °C	(-30...+300 °C)
Class F 0.3 (B):	± (0.30+0.005* T/°C) °C	(-50...+600 °C)
Class F 0.6 (C):	± (0.60+0.06* T/°C) °C	(-50...+600 °C)

Typical Performance Curves

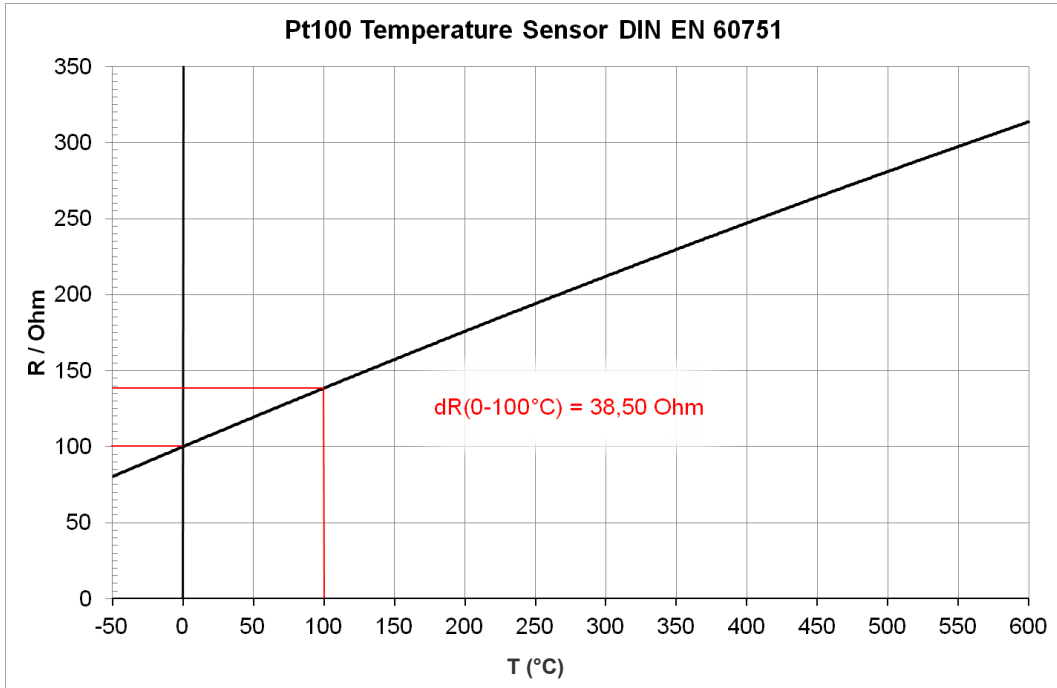

Figure 1: Resistance characteristics



Figure 2: Tolerance chart

PTF TEMPERATURE ELEMENTS

Datasheet

Dimensional Drawing - PTFC Outline

Wire diameter depends on wire material, drawings are for Au-coated Ni-wire



Figure 3: PTFC outline dimensions (mm)

Dimensional Drawing - PTFD Outline

Wire diameter depends on wire material, drawings are for Au-coated Ni-wire



Figure 4: PTFD outline dimensions (mm)

PTF TEMPERATURE ELEMENTS

Datasheet

Mechanical Dimensions PTFF Outline

Wire diameter depends on wire material, drawings are for Au-coated Ni-wire



Figure 5: PTFF outline dimensions (mm)

Dimensional Drawing - PTFM Outline

Wire diameter depends on wire material, drawings are for Au-coated Ni-wire

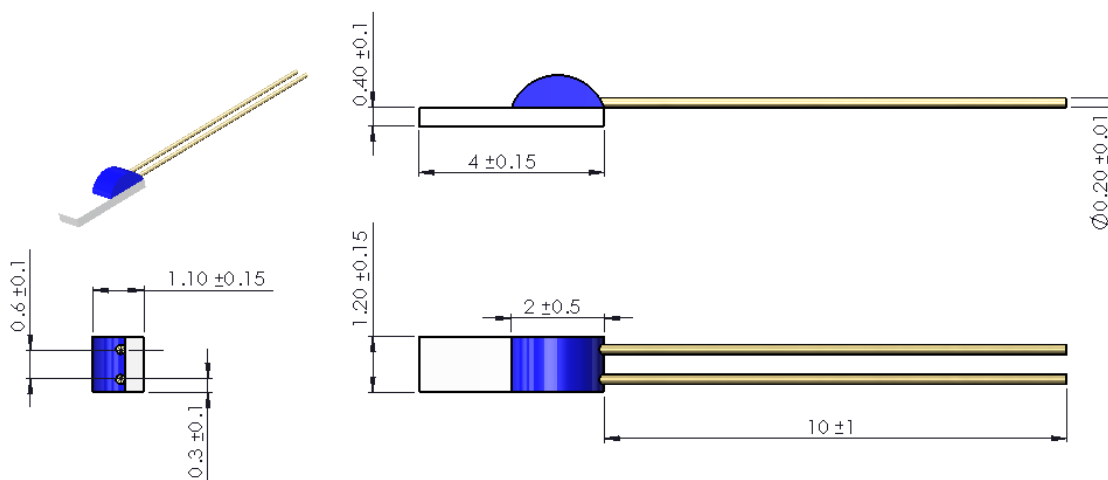

Figure 6: PTFM outline dimensions (mm)

PTF TEMPERATURE ELEMENTS

Datasheet

Type Configuration Matrix

Sensor family	Type	Outline Dimensions	Nominal Resistance		Tolerance Class DIN EN 60751				Connection Wire	
			100 Ω	1000 Ω	T	A	B	C	Ag wire	Ni/Au wire
PTF	C	2.0 x 2.3	101	102	T	A	B	C	1A0	1G0
PTF	D	2.0 x 5.0	101	102	T	A	B	C	1A0	1G0
PTF	F	2.0 x 4.0	101	102	T	A	B	C	1A0	1G0
PTF	M	1.2 x 4.0	101	102	T	A	B	C	1A0	1G0

*Separate datasheet available for the B/Cryo, connect with a specialist for more information

Packing and Minimum Order Quantity

Packing	PCS per Packing unit	MOQ
Transparent Blister Box 80(120)mm x 50(60)mm x 20mm	500 (bulk)	500 per Type

Ordering Information PTFC Outline (2 mm x 2.3 mm)

Part Number	Type	Description
NB-PTCO-005	PTFC101C1G0	100 Ohms, 2.0 mm x 2.3 mm, F 0.6 (C), Au-coated Ni-wire
NB-PTCO-002	PTFC101B1G0	100 Ohms, 2.0 mm x 2.3 mm, F 0.3 (B), Au-coated Ni-wire
NB-PTCO-011	PTFC101A1G0	100 Ohms, 2.0 mm x 2.3 mm, F 0.15 (A), Au-coated Ni-wire
NB-PTCO-058	PTFC101T1G0	100 Ohms, 2.0 mm x 2.3 mm, F 0.1 (T = AA), Au-coated Ni-wire
NB-PTCO-159	PTFC101C1A0	100 Ohms, 2.0 mm x 2.3 mm, F 0.6 (C), Ag-wire
NB-PTCO-160	PTFC101B1A0	100 Ohms, 2.0 mm x 2.3 mm, F 0.3 (B), Ag-wire
NB-PTCO-161	PTFC101A1A0	100 Ohms, 2.0 mm x 2.3 mm, F 0.15 (A), Ag-wire
NB-PTCO-162	PTFC101T1A0	100 Ohms, 2.0 mm x 2.3 mm, F 0.1 (T = AA), Ag-wire
NB-PTCO-046	PTFC102C1G0	1000 Ohms, 2.0 mm x 2.3 mm, F 0.6 (C), Au-coated Ni-wire
NB-PTCO-006	PTFC102B1G0	1000 Ohms, 2.0 mm x 2.3 mm, F 0.3 (B), Au-coated Ni-wire
NB-PTCO-029	PTFC102A1G0	1000 Ohms, 2.0 mm x 2.3 mm, F 0.15 (A), Au-coated Ni-wire
NB-PTCO-154	PTFC102T1G0	1000 Ohms, 2.0 mm x 2.3 mm, F 0.1 (T = AA), Au-coated Ni-wire
NB-PTCO-163	PTFC102C1A0	1000 Ohms, 2.0 mm x 2.3 mm, F 0.6 (C), Ag-wire
NB-PTCO-157	PTFC102B1A0	1000 Ohms, 2.0 mm x 2.3 mm, F 0.3 (B), Ag-wire
NB-PTCO-164	PTFC102A1A0	1000 Ohms, 2.0 mm x 2.3 mm, F 0.15 (A), Ag-wire
NB-PTCO-165	PTFC102T1A0	1000 Ohms, 2.0 mm x 2.3 mm, F 0.1 (T = AA), Ag-wire

PTF TEMPERATURE ELEMENTS

Datasheet

Ordering Information PTFD Outline (2 mm x 5 mm)

Part Number	Type	Description
NB-PTCO-013	PTFD101C1G0	100 Ohms, 2.0 mm x 5.0 mm, F 0.6 (C), Au-coated Ni-wire
NB-PTCO-024	PTFD101B1G0	100 Ohms, 2.0 mm x 5.0 mm, F 0.3 (B), Au-coated Ni-wire
NB-PTCO-037	PTFD101A1G0	100 Ohms, 2.0 mm x 5.0 mm, F 0.15 (A), Au-coated Ni-wire
NB-PTCO-155	PTFD101T1G0	100 Ohms, 2.0 mm x 5.0 mm, F 0.1 (T = AA), Au-coated Ni-wire
NB-PTCO-166	PTFD101C1A0	100 Ohms, 2.0 mm x 5.0 mm, F 0.6 (C), Ag-wire
NB-PTCO-053	PTFD101B1A0	100 Ohms, 2.0 mm x 5.0 mm, F 0.3 (B), Ag-wire
NB-PTCO-158	PTFD101A1A0	100 Ohms, 2.0 mm x 5.0 mm, F 0.15 (A), Ag-wire
NB-PTCO-152	PTFD101T1A0	100 Ohms, 2.0 mm x 5.0 mm, F 0.1 (T = AA), Ag-wire
NB-PTCO-167	PTFD102C1G0	1000 Ohms, 2.0 mm x 5.0 mm, F 0.6 (C), Au-coated Ni-wire
NB-PTCO-126	PTFD102B1G0	1000 Ohms, 2.0 mm x 5.0 mm, F 0.3 (B), Au-coated Ni-wire
NB-PTCO-168	PTFD102A1G0	1000 Ohms, 2.0 mm x 5.0 mm, F 0.15 (A), Au-coated Ni-wire
NB-PTCO-150	PTFD102T1G0	1000 Ohms, 2.0 mm x 5.0 mm, F 0.1 (T = AA), Au-coated Ni-wire
NB-PTCO-169	PTFD102C1A0	1000 Ohms, 2.0 mm x 5.0 mm, F 0.6 (C), Ag-wire
NB-PTCO-035	PTFD102B1A0	1000 Ohms, 2.0 mm x 5.0 mm, F 0.3 (B), Ag-wire
NB-PTCO-170	PTFD102A1A0	1000 Ohms, 2.0 mm x 5.0 mm, F 0.15 (A), Ag-wire
NB-PTCO-151	PTFD102T1A0	1000 Ohms, 2.0 mm x 5.0 mm, F 0.1 (T = AA), Ag-wire

Ordering Information PTFE Outline (2 mm x 4 mm)

Part Number	Type	Description
NB-PTCO-171	PTFF101C1G0	100 Ohms, 2.0 mm x 4.0 mm, F 0.6 (C), Au-coated Ni-wire
NB-PTCO-172	PTFF101B1G0	100 Ohms, 2.0 mm x 4.0 mm, F 0.3 (B), Au-coated Ni-wire
NB-PTCO-173	PTFF101A1G0	100 Ohms, 2.0 mm x 4.0 mm, F 0.15 (A), Au-coated Ni-wire
NB-PTCO-174	PTFF101T1G0	100 Ohms, 2.0 mm x 4.0 mm, F 0.1 (T = AA), Au-coated Ni-wire
NB-PTCO-175	PTFF101C1A0	100 Ohms, 2.0 mm x 4.0 mm, F 0.6 (C), Ag-wire
NB-PTCO-176	PTFF101B1A0	100 Ohms, 2.0 mm x 4.0 mm, F 0.3 (B), Ag-wire
NB-PTCO-177	PTFF101A1A0	100 Ohms, 2.0 mm x 4.0 mm, F 0.15 (A), Ag-wire
NB-PTCO-178	PTFF101T1A0	100 Ohms, 2.0 mm x 4.0 mm, F 0.1 (T = AA), Ag-wire
NB-PTCO-149	PTFF102C1G0	1000 Ohms, 2.0 mm x 4.0 mm, F 0.6 (C), Au-coated Ni-wire
NB-PTCO-101	PTFF102B1G0	1000 Ohms, 2.0 mm x 4.0 mm, F 0.3 (B), Au-coated Ni-wire
NB-PTCO-179	PTFF102A1G0	1000 Ohms, 2.0 mm x 4.0 mm, F 0.15 (A), Au-coated Ni-wire
NB-PTCO-180	PTFF102T1G0	1000 Ohms, 2.0 mm x 4.0 mm, F 0.1 (T = AA), Au-coated Ni-wire
NB-PTCO-181	PTFF102C1A0	1000 Ohms, 2.0 mm x 4.0 mm, F 0.6 (C), Ag-wire
NB-PTCO-182	PTFF102B1A0	1000 Ohms, 2.0 mm x 4.0 mm, F 0.3 (B), Ag-wire
NB-PTCO-183	PTFF102A1A0	1000 Ohms, 2.0 mm x 4.0 mm, F 0.15 (A), Ag-wire
NB-PTCO-184	PTFF102T1A0	1000 Ohms, 2.0 mm x 4.0 mm, F 0.1 (T = AA), Ag-wire