

# 3.3 V 12.288 MHz Audio Oversampling Clock Generator for USB Applications

## NB3N3010B

### Description

The NB3N3010B is a precision, low noise clock multiplier that generates an output frequency of 12.288 MHz. This is accomplished by using Frequency-Locked-Loop (FLL) techniques where a 4 kHz reference input is multiplied by 3072, or an 8 kHz input by 1536. The frequency multiplier is selected by the S0 pin.

The two LVCMOS output drivers are disabled to a logic Low with the ENABLEn pin set HIGH. The NB3N3010B operates from a single +3.3 V supply, and is available in the SOIC-8 pin package. The operating temperature range is from 0°C to +85°C.

The NB3N3010B device provides the optimum combination of low cost, flexibility, and high performance. This makes it ideal for applications such as oversampling A-to-D and D-to-A converters from a low reference frequency, such as a USB start-of-frame (SOF) pulse.

### Features

- Accepts 8 kHz or 4 kHz Reference Input Derived from USB Start-of-Frame
- Generates 12.288 MHz Frequency-Locked to the Reference
- Fully Integrated Frequency-Lock-Loop with Internal Loop Filter
- Low Skew Dual LVCMOS Outputs
- Very Low Phase Noise Preserves Codec Noise Floor
- Internal Voltage Regulator
- Supply Voltage Required: +3.3 V  $\pm 5\%$
- Temperature Range: 0°C to +85°C
- These Devices are Pb-Free, Halogen Free/BFR Free and are RoHS Compliant



ON Semiconductor®

[www.onsemi.com](http://www.onsemi.com)



SOIC-8  
D SUFFIX  
CASE 751

### MARKING DIAGRAM\*

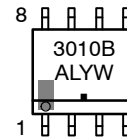

A = Assembly Location  
L = Wafer Lot  
Y = Year  
W = Work Week  
▪ = Pb-Free Package

(Note: Microdot may be in either location)

\*For additional marking information, refer to Application Note [AND8002/D](#).

### ORDERING INFORMATION

Device	Package	Shipping†
NB3N3010BDR2G	SOIC-8 (Pb-Free)	2500 / Tape & Reel

†For information on tape and reel specifications, including part orientation and tape sizes, please refer to our Tape and Reel Packaging Specifications Brochure, [BRD8011/D](#).

# NB3N3010B

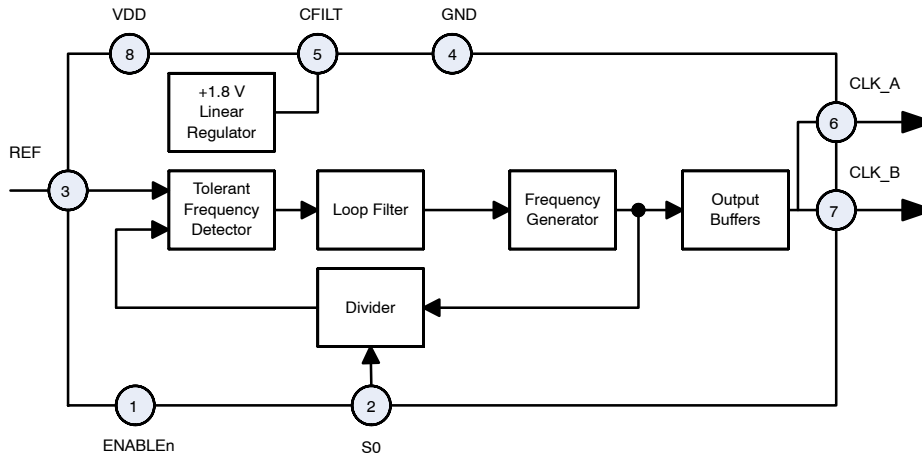

Figure 1. NB3N3010B Simplified Diagram

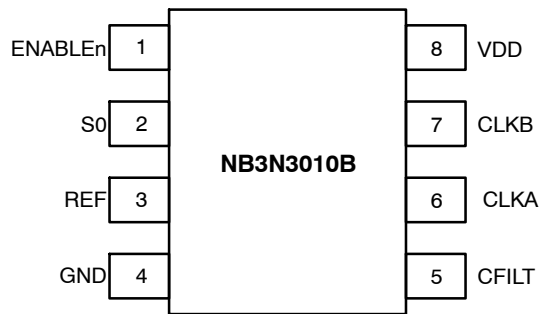

Figure 2. Pinout SOIC-8 (Top View)

Table 1. PIN DESCRIPTION

Pin	Symbol	I/O	Description
1	ENABLEn	LVTTTL/ LVCMOS Input	Low active Output Enable; Defaults HIGH when left open; Internal pull-up resistor to V <sub>DD</sub> .
2	S0	LVTTTL/ LVCMOS Input	Frequency Select Input. See input frequency select Table 2 for details. Defaults HIGH when left open. Internal pull-up resistor to V <sub>DD</sub> .
3	REF	Input	Reference Clock input
4	GND	Power Supply	Negative Supply Voltage; Ground 0 V. This pin provides GND return path to the V <sub>DD</sub> supply.
5	CFILT	Analog	Connection for external filter capacitor for internal +1.8 V regulator; see Figure 4.
6	CLKA	LVCMOS Output	Clock output, copy A (12.288 MHz)
7	CLKB	LVCMOS Output	Clock output, copy B (12.288 MHz)
8	VDD	Power Supply	Positive Supply Voltage, +3.3 V ±5%

# NB3N3010B

**Table 2. ATTRIBUTES**

Characteristic	Value
ESD Protection Human Body Model Machine Model	> 4 kV 400 V
R <sub>PU</sub> – ENABLE <sub>n</sub> Input Pull-up Resistor R <sub>PU</sub> – SO Input Pull-up Resistor	48 kΩ 48 kΩ
Moisture Sensitivity (Note 1) Pb-Free	Level 1
Flammability Rating Oxygen Index: 28 to 34	UL 94 V-0 @ 0.125 in
Transistor Count	12039
Meets or exceeds JEDEC Spec EIA/JESD78 IC Latchup Test	

1. For additional information, see Application Note [AND8003/D](#).

**Table 3. ABSOLUTE MAXIMUM RATINGS**

Symbol	Parameter	Condition 1	Condition 2	Rating	Unit
V <sub>DD</sub>	Positive Power Supply	GND = 0 V		4.6	V
V <sub>I</sub>	Input Voltage (VIN)	GND = 0 V		-0.3 V to V <sub>DD</sub> + 0.3 V	V
T <sub>A</sub>	Operating Temperature Range			0 to +85	°C
T <sub>stg</sub>	Storage Temperature Range			-40 to +150	°C
θ <sub>JA</sub>	Thermal Resistance (Junction-to-Ambient)	0 lfpm 500 lfpm	SOIC-8 SOIC-8	190 130	°C/W °C/W
θ <sub>JC</sub>	Thermal Resistance (Junction-to-Case)	(Note 2)	SOIC-8	41 to 44	°C/W
T <sub>sol</sub>	Wave Solder Pb-Free			265	°C

Stresses exceeding those listed in the Maximum Ratings table may damage the device. If any of these limits are exceeded, device functionality should not be assumed, damage may occur and reliability may be affected.

2. JEDEC standard multilayer board – 2S2P (2 signal, 2 power).

**Table 4. DC CHARACTERISTICS** V<sub>DD</sub> = 3.3 V ±5%, GND = 0 V, T<sub>A</sub> = 0°C to +85°C, Note 3.

Symbol	Characteristic	Min	Typ	Max	Unit
V <sub>DD</sub>	Power Supply Voltage	3.13	3.3	3.47	V
I <sub>DDOEL</sub>	Power Supply Current (operating, i.e. ENABLE <sub>n</sub> is LOW) Outputs Unloaded		21	35	mA
I <sub>DDOEH</sub>	Power Supply Current (standby, i.e. ENABLE <sub>n</sub> is HIGH)		415	600	µA
V <sub>IH</sub>	Input HIGH Voltage (REF, ENABLE <sub>n</sub> , S0)	2.0		V <sub>DD</sub> + 0.3	V
V <sub>IL</sub>	Input LOW Voltage (REF, ENABLE <sub>n</sub> , S0)	GND – 0.3		0.8	V
V <sub>OH</sub>	Output HIGH Voltage (CLKA, CLKB), I <sub>OH</sub> = -12 mA	2.4			V
V <sub>OL</sub>	Output LOW Voltage (CLKA, CLKB), I <sub>OL</sub> = 12 mA			0.4	V

NOTE: Device will meet the specifications after thermal equilibrium has been established when mounted in a test socket or printed circuit board with maintained transverse airflow greater than 500 lfpm.

3. C<sub>FILT</sub> capacitor must be installed; see Figure 4.

## NB3N3010B

**Table 5. AC CHARACTERISTICS**  $V_{DD} = 3.3\text{ V} \pm 5\%$ ,  $GND = 0\text{ V}$ ,  $T_A = 0^\circ\text{C}$  to  $+85^\circ\text{C}$  (Note 4)

Symbol	Characteristic	Min	Typ	Max	Unit
$f_{out}$	Output Clock Frequency: CLKA & CLKB $f_{OUT} = 8\text{ kHz} \times 1536$ $f_{OUT} = 4\text{ kHz} \times 3072$	$S0 = 1$ 12.25728 $S0 = 0$ 12.25728	12.288 12.288	12.31872 12.31872	MHz
$f_{REF}$	Reference Input Frequency	$S0 = 1$ 7.98 $S0 = 0$ 3.99	8 4	8.02 4.01	kHz
$t_{jit(per)-ref}$	Reference Input Period Jitter (pk-pk)			250	ns
$t_{REFH}$	Reference Input Pulse Width (high)	$S0 = 1$ 33 $S0 = 0$ 33		68000 136000	ns
$t_{CLKH}$	CLKA, CLKB output width, high	13			ns
$t_{CLKL}$	CLKA, CLKB output width, low	13			ns
$t_r$	CLKA, CLKB rise time 10% – 90%			4	ns
$t_f$	CLKA, CLKB fall time 90% – 10%			4	ns
$t_{jit(per)}$	CLKA, CLKB period jitter (over 10k cycles)	peak-to-peak RMS		250 20	ps
$t_{jit(cc)}$	CLK_A, CLKB cycle-to-cycle jitter (1k cycles)	peak-to-peak RMS		300 35	ps
$t_{sk(LH)}$	CLKA to CLKB output skew (low-to-high transitions)			700	ps
$t_{sk(HL)}$	CLKA to CLKB output skew (high-to-low transitions)			700	ps
	Power Valid to ENABLEn			10	ms
	ENABLEn to CLKA/CLKB		50	100	ms

NOTE: Device will meet the specifications after thermal equilibrium has been established when mounted in a test socket or printed circuit board with maintained transverse airflow greater than 500 lpm.

4. Outputs loaded with 15 pF max to ground.  $C_{FILT}$  capacitor must be installed; see Figure 4.
5. Maximum time required after power is applied to the MCLK FLL until it is ready to accept ENABLEn active.

# NB3N3010B

## APPLICATION INFORMATION

Figure 1 shows the simplified block diagram of the NB3N3010B device.

The primary function of the NB3N3010B is to accept a selectable 4 kHz or 8 kHz input reference clock, REF, and then multiply it to 12.288 MHz output frequency.

### Frequency Select – S0

Either of two expected input REF frequencies, 4 kHz or 8 kHz, will be multiplied by the FLL to achieve 12.288 MHz at the low-skew CLKA and CLKB outputs by selecting the S0 pin; see Table 6.

The pulse high time ( $T_{HI}$ ) of the input reference signal may vary widely depending on the application. See AC specifications for details.

### Output Enable – ENABLEn

A Low active output enable input pin, ENABLEn, is provided. When the ENABLEn input is High inactive, both clock outputs are driven to a logic Low.

The NB3N3010B implements a delay, specified as ENABLEn to Output Delay in the AC Specifications, from the assertion of ENABLEn to the first rising edges on the clock outputs. This delay insures that CLKA and CLKB output pulses are within specification before the output drivers are enabled. When ENABLEn transitions from Low to High (de-asserts), the current cycle of the clock outputs completes normally then the outputs will be held Low. The ENABLEn signal is asynchronous to either the REF input or CLK\_x outputs.

**Table 6. INPUT FREQUENCY SELECT AND OUTPUT ENABLE FUNCTIONS**

ENABLEn*	S0*	f <sub>REF</sub>	FLL Multiplier	CLKA & CLKB Frequency
0	L	4 kHz	3072	12.288 MHz
0	H	8 kHz	1536	12.288 MHz
1	x	x	x	Disabled Low

\*Defaults High when left open.

### Typical Power On Sequence

1. Power On
2. Reference Clock present; must be switching before ENABLEn goes High.
3. Output Enable, ENABLEn, High-to-Low

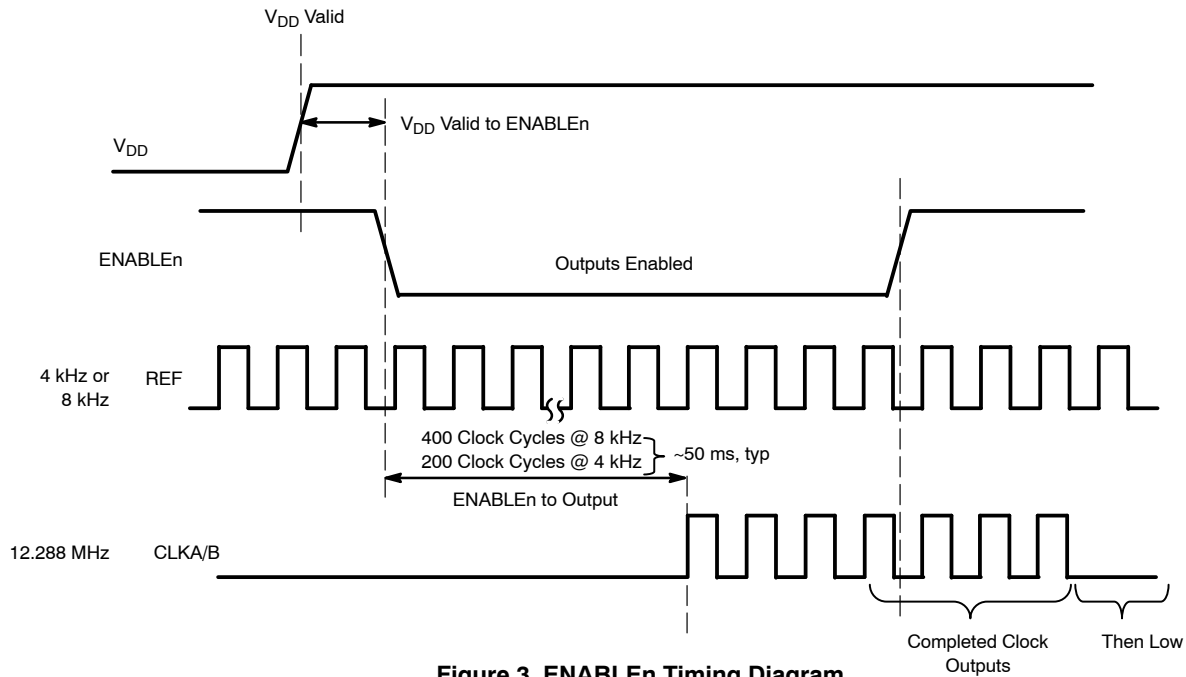

**Figure 3. ENABLEn Timing Diagram**

# NB3N3010B

## CFILT for 1.8 V Regulator

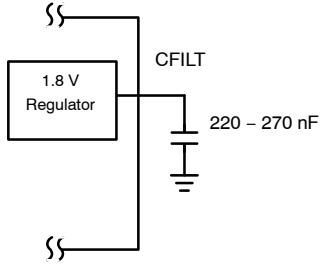

Figure 4. CFILT Capacitor

A low noise 1.8 V LDO/Regulator is integrated to provide a clean supply for the CLKA/CLKB output buffers. The LDO requires a decoupling capacitor in the range of 220 nF to 270 nF for compensation and high frequency PSR, and should be located near the device. The purpose of this design technique is to isolate the high switching noise of the digital outputs from the relatively sensitive internal analog phase-locked loop.

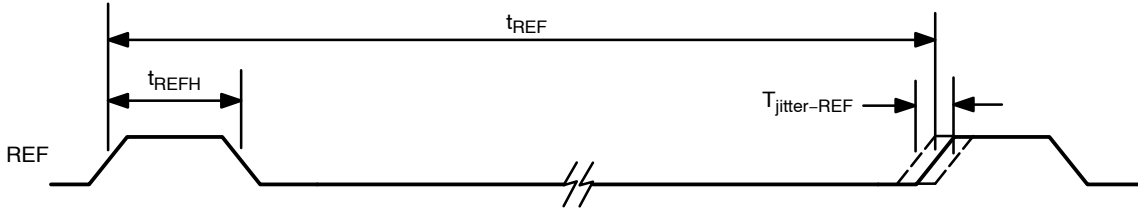

Figure 5. REF Input Timing Diagram

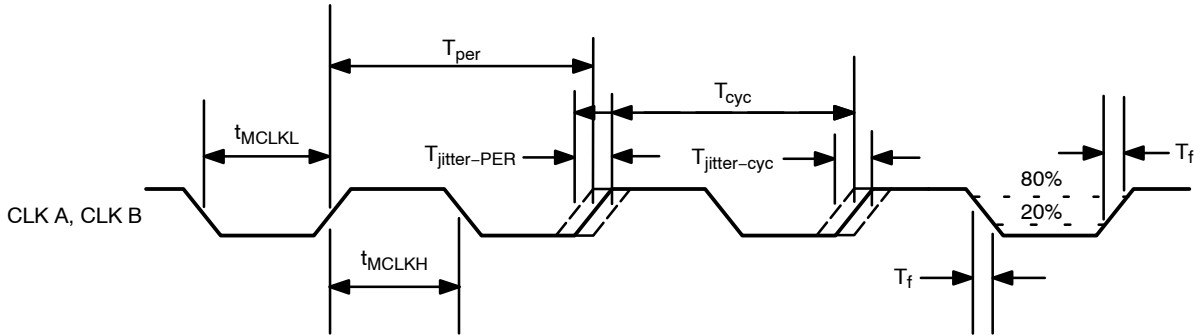

Figure 6. Clock Output Timing Diagram

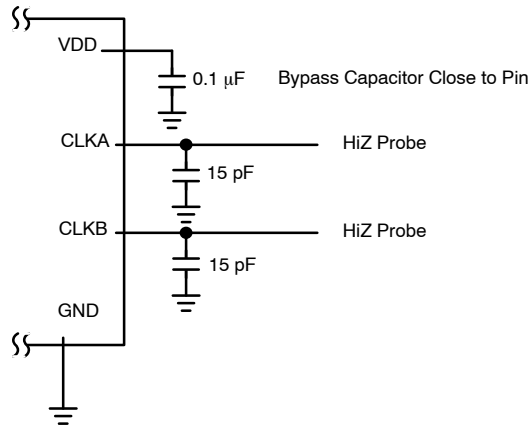

Figure 7. Test Circuit

# MECHANICAL CASE OUTLINE PACKAGE DIMENSIONS

ON Semiconductor®



SCALE 1:1

SOIC-8 NB  
CASE 751-07  
ISSUE AK

DATE 16 FEB 2011

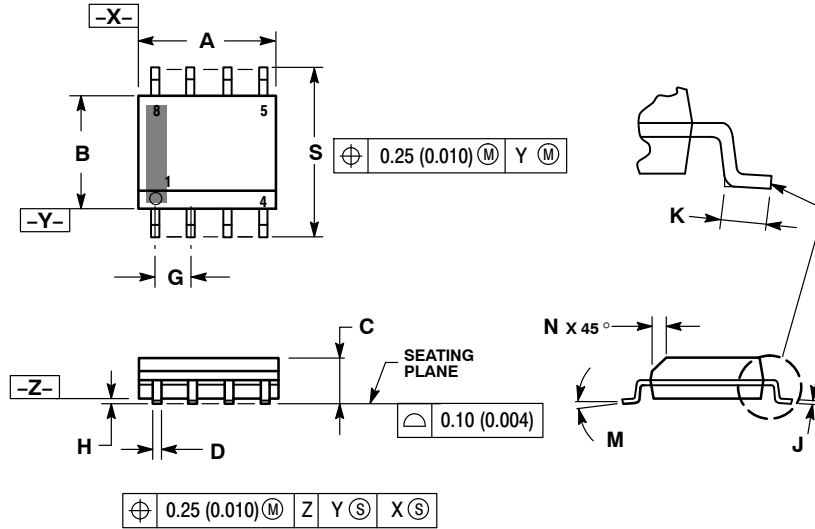

- NOTES:
1. DIMENSIONING AND TOLERANCING PER ANSI Y14.5M, 1982.
  2. CONTROLLING DIMENSION: MILLIMETER.
  3. DIMENSION A AND B DO NOT INCLUDE MOLD PROTRUSION.
  4. MAXIMUM MOLD PROTRUSION 0.15 (0.006) PER SIDE.
  5. DIMENSION D DOES NOT INCLUDE DAMBAR PROTRUSION. ALLOWABLE DAMBAR PROTRUSION SHALL BE 0.127 (0.005) TOTAL IN EXCESS OF THE D DIMENSION AT MAXIMUM MATERIAL CONDITION.
  6. 751-01 THRU 751-06 ARE OBSOLETE. NEW STANDARD IS 751-07.

DIM	MILLIMETERS		INCHES	
	MIN	MAX	MIN	MAX
A	4.80	5.00	0.189	0.197
B	3.80	4.00	0.150	0.157
C	1.35	1.75	0.053	0.069
D	0.33	0.51	0.013	0.020
G	1.27 BSC		0.050 BSC	
H	0.10	0.25	0.004	0.010
J	0.19	0.25	0.007	0.010
K	0.40	1.27	0.016	0.050
M	0°	8°	0°	8°
N	0.25	0.50	0.010	0.020
S	5.80	6.20	0.228	0.244

### SOLDERING FOOTPRINT\*

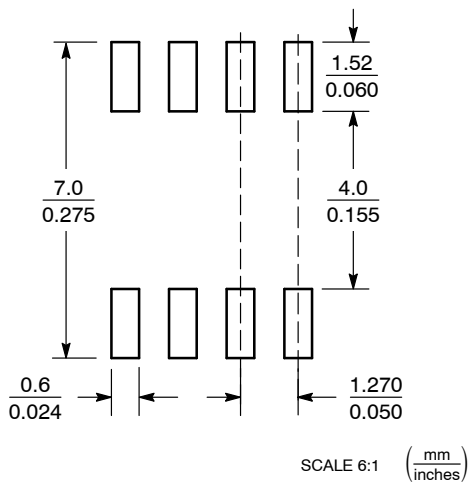

\*For additional information on our Pb-Free strategy and soldering details, please download the ON Semiconductor Soldering and Mounting Techniques Reference Manual, SOLDERRM/D.

### GENERIC MARKING DIAGRAM\*

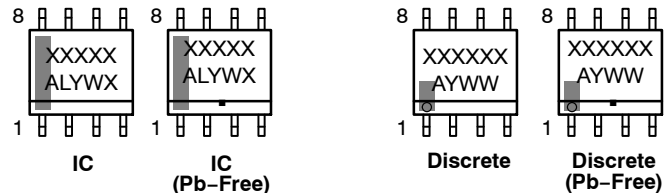

XXXXX = Specific Device Code  
 A = Assembly Location  
 L = Wafer Lot  
 Y = Year  
 W = Work Week  
 ■ = Pb-Free Package

XXXXXX = Specific Device Code  
 A = Assembly Location  
 Y = Year  
 WW = Work Week  
 ■ = Pb-Free Package

\*This information is generic. Please refer to device data sheet for actual part marking. Pb-Free indicator, "G" or microdot "•", may or may not be present. Some products may not follow the Generic Marking.

### STYLES ON PAGE 2

DOCUMENT NUMBER:	98ASB42564B	Electronic versions are uncontrolled except when accessed directly from the Document Repository. Printed versions are uncontrolled except when stamped "CONTROLLED COPY" in red.
DESCRIPTION:	SOIC-8 NB	PAGE 1 OF 2

ON Semiconductor and ON are trademarks of Semiconductor Components Industries, LLC dba ON Semiconductor or its subsidiaries in the United States and/or other countries. ON Semiconductor reserves the right to make changes without further notice to any products herein. ON Semiconductor makes no warranty, representation or guarantee regarding the suitability of its products for any particular purpose, nor does ON Semiconductor assume any liability arising out of the application or use of any product or circuit, and specifically disclaims any and all liability, including without limitation special, consequential or incidental damages. ON Semiconductor does not convey any license under its patent rights nor the rights of others.

**SOIC-8 NB**  
**CASE 751-07**  
**ISSUE AK**

DATE 16 FEB 2011

- |  |   |   |   |
|--|---|---|---|
| <p><b>STYLE 1:</b><br/> PIN 1. EMITTER<br/> 2. COLLECTOR<br/> 3. COLLECTOR<br/> 4. EMITTER<br/> 5. EMITTER<br/> 6. BASE<br/> 7. BASE<br/> 8. EMITTER</p>   | <p><b>STYLE 2:</b><br/> PIN 1. COLLECTOR, DIE, #1<br/> 2. COLLECTOR, #1<br/> 3. COLLECTOR, #2<br/> 4. COLLECTOR, #2<br/> 5. BASE, #2<br/> 6. EMITTER, #2<br/> 7. BASE, #1<br/> 8. EMITTER, #1</p>               | <p><b>STYLE 3:</b><br/> PIN 1. DRAIN, DIE #1<br/> 2. DRAIN, #1<br/> 3. DRAIN, #2<br/> 4. DRAIN, #2<br/> 5. GATE, #2<br/> 6. SOURCE, #2<br/> 7. GATE, #1<br/> 8. SOURCE, #1</p>                            | <p><b>STYLE 4:</b><br/> PIN 1. ANODE<br/> 2. ANODE<br/> 3. ANODE<br/> 4. ANODE<br/> 5. ANODE<br/> 6. ANODE<br/> 7. ANODE<br/> 8. COMMON CATHODE</p>   |
| <p><b>STYLE 5:</b><br/> PIN 1. DRAIN<br/> 2. DRAIN<br/> 3. DRAIN<br/> 4. DRAIN<br/> 5. GATE<br/> 6. GATE<br/> 7. SOURCE<br/> 8. SOURCE</p>   | <p><b>STYLE 6:</b><br/> PIN 1. SOURCE<br/> 2. DRAIN<br/> 3. DRAIN<br/> 4. SOURCE<br/> 5. SOURCE<br/> 6. GATE<br/> 7. GATE<br/> 8. SOURCE</p>  | <p><b>STYLE 7:</b><br/> PIN 1. INPUT<br/> 2. EXTERNAL BYPASS<br/> 3. THIRD STAGE SOURCE<br/> 4. GROUND<br/> 5. DRAIN<br/> 6. GATE 3<br/> 7. SECOND STAGE Vd<br/> 8. FIRST STAGE Vd</p>                    | <p><b>STYLE 8:</b><br/> PIN 1. COLLECTOR, DIE #1<br/> 2. BASE, #1<br/> 3. BASE, #2<br/> 4. COLLECTOR, #2<br/> 5. COLLECTOR, #2<br/> 6. EMITTER, #2<br/> 7. EMITTER, #1<br/> 8. COLLECTOR, #1</p>                              |
| <p><b>STYLE 9:</b><br/> PIN 1. EMITTER, COMMON<br/> 2. COLLECTOR, DIE #1<br/> 3. COLLECTOR, DIE #2<br/> 4. EMITTER, COMMON<br/> 5. EMITTER, COMMON<br/> 6. BASE, DIE #2<br/> 7. BASE, DIE #1<br/> 8. EMITTER, COMMON</p> | <p><b>STYLE 10:</b><br/> PIN 1. GROUND<br/> 2. BIAS 1<br/> 3. OUTPUT<br/> 4. GROUND<br/> 5. GROUND<br/> 6. BIAS 2<br/> 7. INPUT<br/> 8. GROUND</p>  | <p><b>STYLE 11:</b><br/> PIN 1. SOURCE 1<br/> 2. GATE 1<br/> 3. SOURCE 2<br/> 4. GATE 2<br/> 5. DRAIN 2<br/> 6. DRAIN 2<br/> 7. DRAIN 1<br/> 8. DRAIN 1</p>   | <p><b>STYLE 12:</b><br/> PIN 1. SOURCE<br/> 2. SOURCE<br/> 3. SOURCE<br/> 4. GATE<br/> 5. DRAIN<br/> 6. DRAIN<br/> 7. DRAIN<br/> 8. DRAIN</p>   |
| <p><b>STYLE 13:</b><br/> PIN 1. N.C.<br/> 2. SOURCE<br/> 3. SOURCE<br/> 4. GATE<br/> 5. DRAIN<br/> 6. DRAIN<br/> 7. DRAIN<br/> 8. DRAIN</p>  | <p><b>STYLE 14:</b><br/> PIN 1. N-SOURCE<br/> 2. N-GATE<br/> 3. P-SOURCE<br/> 4. P-GATE<br/> 5. P-DRAIN<br/> 6. P-DRAIN<br/> 7. N-DRAIN<br/> 8. N-DRAIN</p>   | <p><b>STYLE 15:</b><br/> PIN 1. ANODE 1<br/> 2. ANODE 1<br/> 3. ANODE 1<br/> 4. ANODE 1<br/> 5. CATHODE, COMMON<br/> 6. CATHODE, COMMON<br/> 7. CATHODE, COMMON<br/> 8. CATHODE, COMMON</p>               | <p><b>STYLE 16:</b><br/> PIN 1. EMITTER, DIE #1<br/> 2. BASE, DIE #1<br/> 3. EMITTER, DIE #2<br/> 4. BASE, DIE #2<br/> 5. COLLECTOR, DIE #2<br/> 6. COLLECTOR, DIE #2<br/> 7. COLLECTOR, DIE #1<br/> 8. COLLECTOR, DIE #1</p> |
| <p><b>STYLE 17:</b><br/> PIN 1. VCC<br/> 2. V2OUT<br/> 3. V1OUT<br/> 4. TXE<br/> 5. RXE<br/> 6. VEE<br/> 7. GND<br/> 8. ACC</p>  | <p><b>STYLE 18:</b><br/> PIN 1. ANODE<br/> 2. ANODE<br/> 3. SOURCE<br/> 4. GATE<br/> 5. DRAIN<br/> 6. DRAIN<br/> 7. CATHODE<br/> 8. CATHODE</p>   | <p><b>STYLE 19:</b><br/> PIN 1. SOURCE 1<br/> 2. GATE 1<br/> 3. SOURCE 2<br/> 4. GATE 2<br/> 5. DRAIN 2<br/> 6. MIRROR 2<br/> 7. DRAIN 1<br/> 8. MIRROR 1</p>   | <p><b>STYLE 20:</b><br/> PIN 1. SOURCE (N)<br/> 2. GATE (N)<br/> 3. SOURCE (P)<br/> 4. GATE (P)<br/> 5. DRAIN<br/> 6. DRAIN<br/> 7. DRAIN<br/> 8. DRAIN</p>   |
| <p><b>STYLE 21:</b><br/> PIN 1. CATHODE 1<br/> 2. CATHODE 2<br/> 3. CATHODE 3<br/> 4. CATHODE 4<br/> 5. CATHODE 5<br/> 6. COMMON ANODE<br/> 7. COMMON ANODE<br/> 8. CATHODE 6</p>  | <p><b>STYLE 22:</b><br/> PIN 1. I/O LINE 1<br/> 2. COMMON CATHODE/VCC<br/> 3. COMMON CATHODE/VCC<br/> 4. I/O LINE 3<br/> 5. COMMON ANODE/GND<br/> 6. I/O LINE 4<br/> 7. I/O LINE 5<br/> 8. COMMON ANODE/GND</p> | <p><b>STYLE 23:</b><br/> PIN 1. LINE 1 IN<br/> 2. COMMON ANODE/GND<br/> 3. COMMON ANODE/GND<br/> 4. LINE 2 IN<br/> 5. LINE 2 OUT<br/> 6. COMMON ANODE/GND<br/> 7. COMMON ANODE/GND<br/> 8. LINE 1 OUT</p> | <p><b>STYLE 24:</b><br/> PIN 1. BASE<br/> 2. EMITTER<br/> 3. COLLECTOR/ANODE<br/> 4. COLLECTOR/ANODE<br/> 5. CATHODE<br/> 6. CATHODE<br/> 7. COLLECTOR/ANODE<br/> 8. COLLECTOR/ANODE</p>                                      |
| <p><b>STYLE 25:</b><br/> PIN 1. VIN<br/> 2. N/C<br/> 3. REXT<br/> 4. GND<br/> 5. IOUT<br/> 6. IOUT<br/> 7. IOUT<br/> 8. IOUT</p>   | <p><b>STYLE 26:</b><br/> PIN 1. GND<br/> 2. dv/dt<br/> 3. ENABLE<br/> 4. ILIMIT<br/> 5. SOURCE<br/> 6. SOURCE<br/> 7. SOURCE<br/> 8. VCC</p>  | <p><b>STYLE 27:</b><br/> PIN 1. ILIMIT<br/> 2. OVLO<br/> 3. UVLO<br/> 4. INPUT+<br/> 5. SOURCE<br/> 6. SOURCE<br/> 7. SOURCE<br/> 8. DRAIN</p>  | <p><b>STYLE 28:</b><br/> PIN 1. SW_TO_GND<br/> 2. DASIC_OFF<br/> 3. DASIC_SW_DET<br/> 4. GND<br/> 5. V_MON<br/> 6. VBULK<br/> 7. VBULK<br/> 8. VIN</p>  |
| <p><b>STYLE 29:</b><br/> PIN 1. BASE, DIE #1<br/> 2. EMITTER, #1<br/> 3. BASE, #2<br/> 4. EMITTER, #2<br/> 5. COLLECTOR, #2<br/> 6. COLLECTOR, #2<br/> 7. COLLECTOR, #1<br/> 8. COLLECTOR, #1</p>                        | <p><b>STYLE 30:</b><br/> PIN 1. DRAIN 1<br/> 2. DRAIN 1<br/> 3. GATE 2<br/> 4. SOURCE 2<br/> 5. SOURCE 1/DRAIN 2<br/> 6. SOURCE 1/DRAIN 2<br/> 7. SOURCE 1/DRAIN 2<br/> 8. GATE 1</p>                           |   |   |

<b>DOCUMENT NUMBER:</b>	<b>98ASB42564B</b>	Electronic versions are uncontrolled except when accessed directly from the Document Repository. Printed versions are uncontrolled except when stamped "CONTROLLED COPY" in red.
<b>DESCRIPTION:</b>	<b>SOIC-8 NB</b>	<b>PAGE 2 OF 2</b>

ON Semiconductor and  are trademarks of Semiconductor Components Industries, LLC dba ON Semiconductor or its subsidiaries in the United States and/or other countries. ON Semiconductor reserves the right to make changes without further notice to any products herein. ON Semiconductor makes no warranty, representation or guarantee regarding the suitability of its products for any particular purpose, nor does ON Semiconductor assume any liability arising out of the application or use of any product or circuit, and specifically disclaims any and all liability, including without limitation special, consequential or incidental damages. ON Semiconductor does not convey any license under its patent rights nor the rights of others.