

ON Semiconductor

Is Now

onsemi™

To learn more about onsemi™, please visit our website at
www.onsemi.com

onsemi and **onsemi** and other names, marks, and brands are registered and/or common law trademarks of Semiconductor Components Industries, LLC dba "**onsemi**" or its affiliates and/or subsidiaries in the United States and/or other countries. **onsemi** owns the rights to a number of patents, trademarks, copyrights, trade secrets, and other intellectual property. A listing of **onsemi** product/patent coverage may be accessed at www.onsemi.com/site/pdf/Patent-Marking.pdf. **onsemi** reserves the right to make changes at any time to any products or information herein, without notice. The information herein is provided "as-is" and **onsemi** makes no warranty, representation or guarantee regarding the accuracy of the information, product features, availability, functionality, or suitability of its products for any particular purpose, nor does **onsemi** assume any liability arising out of the application or use of any product or circuit, and specifically disclaims any and all liability, including without limitation special, consequential or incidental damages. Buyer is responsible for its products and applications using **onsemi** products, including compliance with all laws, regulations and safety requirements or standards, regardless of any support or applications information provided by **onsemi**. "Typical" parameters which may be provided in **onsemi** data sheets and/or specifications can and do vary in different applications and actual performance may vary over time. All operating parameters, including "Typicals" must be validated for each customer application by customer's technical experts. **onsemi** does not convey any license under any of its intellectual property rights nor the rights of others. **onsemi** products are not designed, intended, or authorized for use as a critical component in life support systems or any FDA Class 3 medical devices or medical devices with a same or similar classification in a foreign jurisdiction or any devices intended for implantation in the human body. Should Buyer purchase or use **onsemi** products for any such unintended or unauthorized application, Buyer shall indemnify and hold **onsemi** and its officers, employees, subsidiaries, affiliates, and distributors harmless against all claims, costs, damages, and expenses, and reasonable attorney fees arising out of, directly or indirectly, any claim of personal injury or death associated with such unintended or unauthorized use, even if such claim alleges that **onsemi** was negligent regarding the design or manufacture of the part. **onsemi** is an Equal Opportunity/Affirmative Action Employer. This literature is subject to all applicable copyright laws and is not for resale in any manner. Other names and brands may be claimed as the property of others.

3.3 V USB 3.1 Gen-2 10 Gbps Dual Channel / Single Port Linear Redriver

NB7NPQ1002M

Description

The NB7NPQ1002M is a high performance single-Port linear redriver designed for USB 3.1 Gen 1 and USB 3.1 Gen 2 applications that supports both 5 Gbps and 10 Gbps data rates. Signal integrity degrades from PCB traces, transmission cables, and inter-symbol interference (ISI). The NB7NPQ1002M compensates for these losses by engaging varying levels of equalization at the input receiver, and flat gain amplification on the output transmitter.

The NB7NPQ1002M offers programmable equalization and flat gain to optimize performance over various physical mediums.

The NB7NPQ1002M contains an automatic receiver detect function which will determine whether the output is active. The receiver detection loop will be active if the corresponding channel's signal detector is idle for a period of time. The channel will then move to Unplug Mode if a load is not detected, or it will return to Low Power Mode (Slumber mode) due to inactivity. Both the channels are independent with individual controls.

The NB7NPQ1002M comes in a 2.5 x 4.5 mm WQFN30 package and is specified to operate across the entire industrial temperature range, -40°C to 85°C.

Features

- 3.3 V \pm 0.3 V Power Supply
- 5 Gbps & 10 Gbps Serial Link with Linear Amplifier
- Device Supports USB 3.1 Gen 1 and USB 3.1 Gen 2 Data Rates
- USB 3.1 Super Speed Gen1 & Gen2 Standard Compliant
- Automatic Receiver Detection
- Integrated Input and Output Termination
- Pin Adjustable Receiver Equalization and Flat Gain
- Pin Adjustable Output Linear Swing
- 100 Ω Differential CML I/O's
- Auto Slumber Mode for Adaptive Power Management
- Hot-Plug Capable
- ESD Protection \pm 2 kV HBM
- Operating Temperature Range Industrial: -40°C to +85°C
- Package: WQFN30, 2.5 x 4.5 mm
- This is a Pb-Free Device

Typical Applications

- USB3.1 Type-A and Type-C Signal Routing
- Mobile Phone and Tablet
- Computer, Laptop and Notebook
- External Storage Device
- Docking Station and Dongle
- Active Cable, Back Planes
- Gaming Console, Smart T.V



ON Semiconductor®

www.onsemi.com

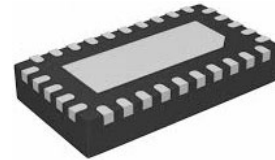

WQFN30
CASE 510CK

MARKING DIAGRAM

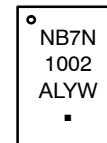

- A = Assembly Location
- L = Wafer Lot
- Y = Year
- W = Work Week
- = Pb-Free Package

ORDERING INFORMATION

Device	Package	Shipping†
NB7NPQ1002MMTTWG	WQFN30 (Pb-Free)	3000 / Tape & Reel

†For information on tape and reel specifications, including part orientation and tape sizes, please refer to our Tape and Reel Packaging Specification Brochure, BRD8011/D.

NB7NPQ1002M

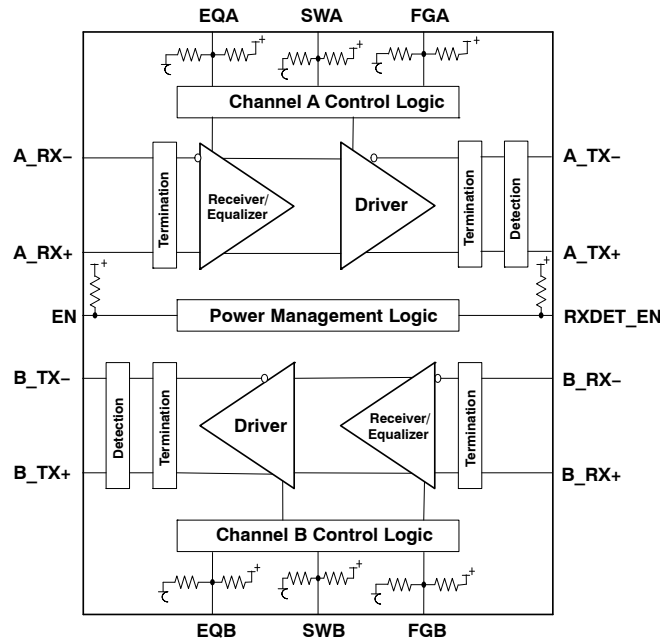

Figure 1. Logic Diagram of NB7NPQ1002M

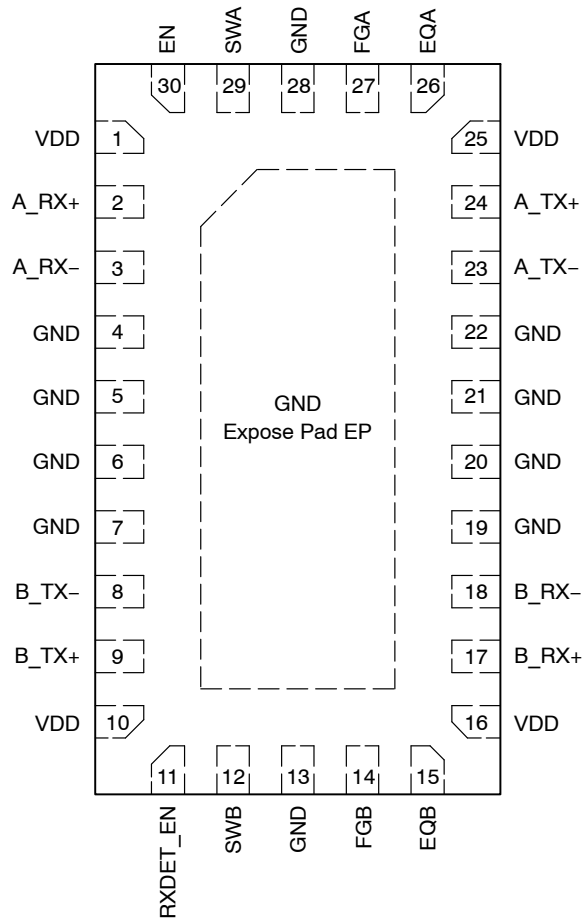

Figure 2. WQFN30 Package Pinout (Top View)

NB7NPQ1002M

Table 1. PIN DESCRIPTION

Pin Number	Pin Name	Type	Description
1, 10, 16, 25	VDD	POWER	3.3 V power supply. V _{DD} pins must be externally connected to power supply.
2	A_RX+	INPUT	Channel A Differential CML input pair for 5 / 10 Gbps USB signals with selectable input termination between 50 Ω to V _{DD} or 67 kΩ to GND. Must be externally AC-coupled in system. UFP/DFP transmitter should provide this capacitor.
3	A_RX-		
4 – 7, 13, 19 – 22, 28	GND	GND	Supply Ground. All GND pins must be externally connected to Ground.
8	B_TX-	OUTPUT	Channel B Differential output for 5 / 10 Gbps USB signals. Must be externally AC-coupled in system.
9	B_TX+		
11	RXDET_EN	INPUT	Pin for Receiver detection Enable having an internal 300 kΩ pull-up resistor. HIGH “1” where pin is connected to V _{DD} , LOW “0” where pin is connected to Ground. Default is “1” Pin is Enabled, Low Pin is disabled.
12	SWB	INPUT	Pin for control of Channel B Swing levels having an internal 100 kΩ pull up and 200 kΩ pull-down resistors. 4 state input: HIGH “H” where pin is connected to V _{DD} , LOW “L” where pin is connected to Ground, FLOAT “F” where the pin is left floating (open) and Rext “R” where an external resistor Rext 68 kΩ is connected from pin to Ground. FLOAT “F” is the default setting.
14	FGB	INPUT	Pin for control of Channel B Flat Gain setting having internal 100 kΩ pull up and 200 kΩ pull-down resistors. 4 state input: HIGH “H” where pin is connected to V _{DD} , LOW “L” where pin is connected to Ground, FLOAT “F” where the pin is left floating (open) and Rext “R” where an external resistor Rext 68 kΩ is connected from pin to Ground. FLOAT “F” is the default setting.
15	EQB	INPUT	Pin for control of Channel B Equalization setting having internal 100 kΩ pull up and 200 kΩ pull-down resistors. 4 state input: HIGH “H” where pin is connected to V _{DD} , LOW “L” where pin is connected to Ground, FLOAT “F” where the pin is left floating (open) and Rext “R” where an external resistor Rext 68 kΩ is connected from pin to Ground. FLOAT “F” is the default setting.
17	B_RX+	INPUT	Channel B Differential CML input pair for 5 / 10 Gbps USB signals with selectable input termination between 50 Ω to V _{DD} or 67 kΩ to GND. Must be externally AC-coupled in system. UFP/DFP transmitter should provide this capacitor.
18	B_RX-		
23	A_TX-	OUTPUT	Channel A Differential output for 5 / 10 Gbps USB signals. Must be externally AC-coupled in system.
24	A_TX+		
26	EQA	INPUT	Pin for control of Channel A Equalization setting having internal 100 kΩ pull up and 200 kΩ pull-down resistors. 4 state input: HIGH “H” where pin is connected to V _{DD} , LOW “L” where pin is connected to Ground, FLOAT “F” where the pin is left floating (open) and Rext “R” where an external resistor Rext 68 kΩ is connected from pin to Ground. FLOAT “F” is the default setting.
27	FGA	INPUT	Pin for control of Channel A Flat Gain setting having internal 100 kΩ pull up and 200 kΩ pull-down resistors. 4 state input: HIGH “H” where pin is connected to V _{DD} , LOW “L” where pin is connected to Ground, FLOAT “F” where the pin is left floating (open) and Rext “R” where an external resistor Rext 68 kΩ is connected from pin to Ground. FLOAT “F” is the default setting.
29	SWA	INPUT	Pin for control of Channel A Swing levels having internal 100 kΩ pull up and 200 kΩ pull-down resistors. 4 state input: HIGH “H” where pin is connected to V _{DD} , LOW “L” where pin is connected to Ground, FLOAT “F” where the pin is left floating (open) and Rext “R” where an external resistor Rext 68 kΩ is connected from pin to Ground. FLOAT “F” is the default setting.
30	EN	INPUT	Pin for device channel Enable having an internal 300 kΩ pull-up resistor. HIGH “1” where pin is connected to V _{DD} , LOW “0” where pin is connected to Ground. Default is “1” Pin is Enabled, Low Pin is disabled.
EP	GND	GND	Exposed pad (EP). EP on the package bottom is thermally connected to the die for improved heat transfer out of the package. The exposed pad is electrically connected to the die and must be soldered to GND on the PC Board.

Power Management

The NB7NPQ1002M has an adaptive power management feature in order to minimize power consumption. When there is no termination detected, the corresponding channel will change to low power slumber mode. Accordingly, both channels will move to low power slumber mode individually. Both the channels are independent with separate controls.

While in the low power slumber mode, the receiver signal detector will continue to monitor the input channel. If a channel is in low power slumber mode, the receiver detection loop will be active again. If a load is not detected, then the channel will move to Device Unplug Mode and continuously monitor for the load. When a load is detected, the channel will return to Low Power Slumber Mode and receiver detection will be active again per 6 ms.

NB7NPQ1002M

Table 2. OPERATING MODES

Modes	RIN	ROUT
Power Down Mode	67 k Ω to Ground	High Z
Unplug Mode	High Z	40 k Ω to V _{DD}
Low Power Slumber Mode	50 Ω to V _{DD}	40 k Ω to V _{DD}
Active Mode	50 Ω to V _{DD}	50 Ω to V _{DD}

Table 3. EQUALIZATION SETTINGS:

EQA/ EQB	EQ (dB)	
	@ 2.5 GHz	@ 5 GHz
Low "L" (Pin tied to Ground)	5.1	10.9
Rext "R" (68 k Ω tied from pin to Ground)	1.9	6.7
FLOAT "F" (Pin open)	3.5	8.9 (Default)
HIGH "H" (Pin tied to V _{DD})	6.8	13.1

Table 4. FLAT GAIN SETTING

FGA/ FGB	FG (dB)
Low "L" (Pin tied to Ground)	-3
Rext "R" (68 k Ω tied from pin to Ground)	-1.5
FLOAT "F" (Pin open)	0 (Default)
HIGH "H" (Pin tied to V _{DD})	+2

Table 8. ATTRIBUTES

Parameter		
ESD Protection	Human Body Model Charged Device Model	± 2 kV > 1.5 kV
Moisture Sensitivity, Indefinite Time Out of Dry pack (Note 1)		Level 1
Flammability Rating	Oxygen Index: 28 to 34	UL 94 V-O @ 0.125 in
Transistor Count		40517
Meets or exceeds JEDEC Spec EIA/JESD78 IC Latch-up Test		

1. For additional information, see Application Note AND8003/D.

Table 9. ABSOLUTE MAXIMUM RATINGS Over operating free-air temperature range (unless otherwise noted)

Parameter	Description	Min	Max	Unit
Supply Voltage (Note 2)	V _{DD}	-0.5	4.6	V
Voltage range at any input or output terminal	Differential I/O	-0.5	V _{DD} + 0.5	V
	LVC MOS inputs	-0.5	V _{DD} + 0.5	V
Output Current		-25	+25	mA
Power Dissipation, Continuous			1.0	W
Storage Temperature Range, T _{SG}		-65	150	$^{\circ}$ C
Maximum Junction Temperature, T _J			125	$^{\circ}$ C
Junction-to-Ambient Thermal Resistance @ 500 lfm, θ_{JA} (Note 3)			TBD	$^{\circ}$ C/W
Wave Solder, Pb-Free, T _{SOL}			265	$^{\circ}$ C

Stresses exceeding those listed in the Maximum Ratings table may damage the device. If any of these limits are exceeded, device functionality should not be assumed, damage may occur and reliability may be affected.

2. All voltage values are with respect to the GND terminals.

3. JEDEC standard multilayer board - 2S2P (2 signal, 2 power).

Table 5. SWING SETTING

SWA/ SWB	SW (mVppd)
Low "L" (Pin tied to Ground)	800
Rext "R" (68 k Ω tied from pin to Ground)	1200
FLOAT "F" (Pin open)	1000 (Default)
HIGH "H" (Pin tied to V _{DD})	1100

Table 6. CHANNEL ENABLE SETTING

EN	Status
Low "0" (Pin tied to Ground)	Disabled
HIGH "1" (Pin tied to V _{DD})	Enabled (Default)

Table 7. RECEIVER DETECTION SETTING

RXDET_EN	Status
Low "0" (Pin tied to Ground)	Disabled
HIGH "1" (Pin tied to V _{DD})	Enabled (Default)

NB7NPQ1002M

Table 10. RECOMMENDED OPERATING CONDITIONS Over operating free-air temperature range (unless otherwise noted)

Parameter	Description	Min	Typ	Max	Unit
V _{DD}	Main power supply	3.0	3.3	3.6	V
T _A	Operating free-air temperature	Industrial Temperature Range		+85	°C
C _{AC}	AC coupling capacitor	75	100	265	nF
R _{ext}	External Resistor for input control setting "R", ± 5%		68		kΩ

Functional operation above the stresses listed in the Recommended Operating Ranges is not implied. Extended exposure to stresses beyond the Recommended Operating Ranges limits may affect device reliability.

Table 11. POWER SUPPLY CHARACTERISTICS and LATENCY

Symbol	Parameter	Test Conditions	Min	Typ (Note 4)	Max	Unit
V _{DD}	Supply Voltage		3.0	3.3	3.6	V
I _{DDActive}	Active mode current	EN = 1, 10 Gbps, compliance test pattern		115		mA
I _{DDLPSlumber}	Low Power Slumber mode current	EN = 1, no input signal longer than TLP-Slumber		0.4	0.64	mA
I _{DDUnplug}	Unplug mode current	EN = 1, no output load is detected		0.36	0.45	mA
I _{DDpd}	Power-down mode current	EN = 0		10	50	μA
tpd	Latency	From Input to Output			2	ns

4. TYP values use V_{DD} = 3.3 V, T_A = 25°C

Table 12. CML RECEIVER AC/DC CHARACTERISTICS

V_{DD} = 3.3 V ± 0.3 V Over operating free-air temperature range (unless otherwise noted)

Symbol	Parameter	Test Conditions	Min	Typ	Max	Unit
R _{RX-DIFF-DC}	Differential Input Impedance (DC)		72	100	120	Ω
R _{RX-SINGLE-DC}	Single-ended Input Impedance (DC)	Measured with respect to GND over a voltage of 500 mV max.	18		30	Ω
Z _{RX-HIZ-DC-PD}	Common-mode input impedance for V>0 during reset or power-down (DC)	VCM = 0 to 500 mV	25			kΩ
V _{RX-CM-AC-P}	Common mode peak voltage	AC up to 5 GHz			150	mVpeak
V _{RX-CM-DC-Active-Idle-Delta-P}	Common mode peak voltage	Between U0 and U1. AC up to 5 GHz			200	mVpeak
	$ AvgU0(V_{RX-D+}+V_{RX-D-})/2 - AvgU1(V_{RX-D+}+V_{RX-D-})/2 $					

Product parametric performance is indicated in the Electrical Characteristics for the listed test conditions, unless otherwise noted. Product performance may not be indicated by the Electrical Characteristics if operated under different conditions.

Table 13. LVCMOS CONTROL PIN CHARACTERISTICS

V_{DD} = 3.3 V ± 0.3 V Over operating free-air temperature range (unless otherwise noted)

Symbol	Parameter	Test Conditions	Min	Typ	Max	Unit
--------	-----------	-----------------	-----	-----	-----	------

2-LEVEL CONTROL PINS LVCMOS INPUTS (EN, RXDET_EN)

V _{IH}	DC Input Logic HIGH "1"		0.65 * V _{DD}	V _{DD}	V _{DD}	V
V _{IL}	DC Input Logic LOW "0"		GND	GND	0.35 * V _{DD}	V
I _{IH}	High-level input current				25	μA
I _{IL}	Low-level input current		-25			μA

4-LEVEL CONTROL PINS LVCMOS INPUTS (EQA/EQB, FGA/FGB, SWA/SWB)

V _{IH}	DC Input Logic HIGH; Setting "H"	Input pin connected to V _{DD}	0.92 * V _{DD}	V _{DD}		V
V _{IF}	DC Input Logic FLOAT; Setting "F"	Input pin FLOAT (open) (Note 5), Logic 2/3 * V _{DD}	0.59 * V _{DD}	0.67 * V _{DD}	0.75 * V _{DD}	V
V _{IR}	DC Input Logic Rext; Setting "R"	Rext resistor 68 kΩ must be connected between pin and GND, Logic 1/3 * V _{DD}	0.25 * V _{DD}	0.33 * V _{DD}	0.41 * V _{DD}	V
V _{IL}	DC Input Logic LOW; Setting "L"	Input pin connected to GND		GND	0.08 * V _{DD}	V
I _{IH}	High-level input current				50	μA
I _{IL}	Low-level input current		-50			μA

5. Floating refers to a pin left in an open state, with no external connections.

NB7NPQ1002M

Table 14. TRANSMITTER AC/DC CHARACTERISTICS

$V_{DD} = 3.3 \text{ V} \pm 0.3 \text{ V}$ Over operating free-air temperature range (unless otherwise noted)

Parameter		Test Conditions	Min	Typ	Max	Unit
$V_{TX-DIFF-PP}$	Output differential p-p voltage swing at 100 MHz	Differential Swing $ V_{TX-D+} - V_{TX-D-} $			1.2	V_{PPd}
$R_{TX-DIFF-DC}$	Differential TX impedance (DC)		72		120	Ω
$V_{TX-RCV-DET}$	Voltage change allowed during receiver detect				600	mV
Cac_coupling	AC coupling capacitance		75		265	nF
TTX-EYE (10 Gbps)	Transmitter eye, Include all jitter	At the silicon pad. 10 Gbps	0.646			UI
TTX-EYE (5 Gbps)	Transmitter eye, Include all jitter	At the silicon pad. 5 Gbps	0.625			UI
TTX-DJ-DD (10 Gbps)	Transmitter deterministic jitter	At the silicon pad. 10 Gbps			0.17	UI
TTX-DJ-DD (5 Gbps)	Transmitter deterministic jitter	At the silicon pad. 5 Gbps			0.205	UI
Ctxparasitic	Parasitic capacitor for TX				1.1	pF
$R_{TX-DC-CM}$	Common-mode output impedance (DC)		18		30	Ω
$V_{TX-DC-CM}$	Instantaneous allowed DC common mode voltage at the connector side of the AC coupling capacitors	$ V_{TX-D+} + V_{TX-D-} /2$	0		2.2	V
V_{TX-C}	Common-mode voltage	$ V_{TX-D+} + V_{TX-D-} /2$	$V_{DD} - 1.5$		V_{DD}	V
$V_{TX-CM-AC-PP-Active}$	TX AC common-mode peak-to-peak voltage swing in active mode	$V_{TX-D+} + V_{TX-D-}$ for both time and amplitude			100	mV _{PP}
$V_{TX-CM-DC-Active_Idle-Delta}$	Common mode delta voltage $ \text{Avg}U0(V_{TX-D+} + V_{TX-D-})/2 - \text{Avg}U1(V_{TX-D+} + V_{TX-D-})/2 $	Between U0 to U1			200	mV-peak
$V_{TX-Idle-DIFF-AC-pp}$	Idle mode AC common mode delta voltage $ V_{TX-D+} - V_{TX-D-} $	Between TX+ and TX- in idle mode. Use the HPF to remove DC components. 1/LPF. No AC and DC signals are applied to RX terminals.			10	mV _{ppd}
$V_{TX-Idle-DIFF-DC}$	Idle mode DC common mode delta voltage $ V_{TX-D+} - V_{TX-D-} $	Between TX+ and TX- in idle mode. Use the LPF to remove DC components. 1/HPF. No AC and DC signals are applied to RX terminals.			10	mV

CHANNEL PERFORMANCE

Gp	Peaking gain (Compensation at 5 GHz, relative to 100 MHz, 100 mVp-p sine wave input)	EQx = L		10.9	dB
		EQx = R		6.7	
		EQx = F		8.9	
		EQx = H		13.1	
	Variation around typical		-3	+3	dB
Gf	Flat Gain (100 MHz, EQx=F, SWx=F)	FGx = L		-3	dB
		FGx = R		-1.5	
		FGx = F		0	
		FGx = H		+2	
	Variation around typical		-3	+3	dB
V_{SW_100M}	-1 dB compression point output swing (100MHz)	SWx = L		800	mV _{ppd}
		SWx = R		1200	
		SWx = F		1000	
		SWx = H		1100	

NB7NPQ1002M

Table 14. TRANSMITTER AC/DC CHARACTERISTICS

$V_{DD} = 3.3\text{ V} \pm 0.3\text{ V}$ Over operating free-air temperature range (unless otherwise noted)

Parameter	Test Conditions	Min	Typ	Max	Unit
CHANNEL PERFORMANCE					
V_{SW_5G}	-1 dB compression point output swing (5 GHz)	SWx = L SWx = R SWx = F SWx = H		600 900 750 825	mVppd
DDNEXT	Differential near-end crosstalk (Note 6)	100MHz to 5GHz, RXDET_EN = 1 Figure 3		-40	dB

SIGNAL AND FREQUENCY DETECTORS

V_{th_dsm}	Low power slumber mode detector threshold	LFPS signal threshold in Low power Slumber mode	100		600	mVppd
V_{th_am}	Active mode detector threshold	Signal threshold in Active and Slumber mode	45		175	mVppd

6. Measured using a Vector Network Analyzer (VNA) with -15 dbm power level applied to the adjacent input. The VNA detects the signal at the output of the victim channel. All other inputs and outputs are terminated with 50-Ω.

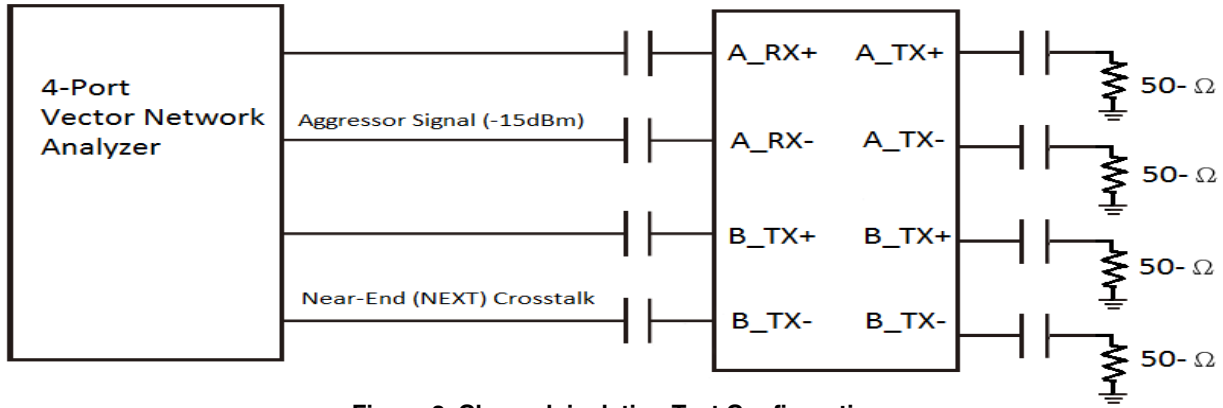

Figure 3. Channel-isolation Test Configuration

NB7NPQ1002M

Typical Application:

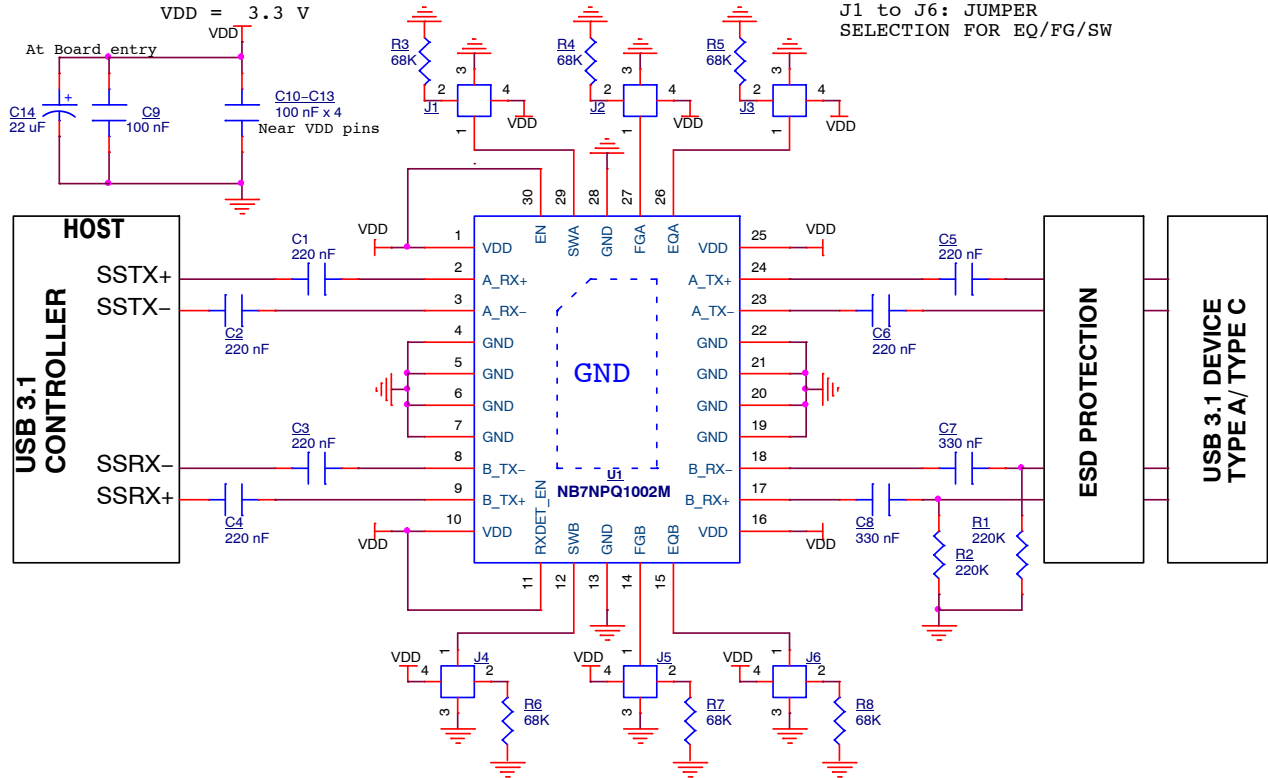

Figure 4. USB 3.1 Host Side NB7NPQ1002M Application

Table 15. DESIGN REQUIREMENTS

Design Parameter	Value
Supply Voltage	3.3 V nominal, (3.0 V to 3.6 V)
Operation Mode (Control Pin Selection)	Default FLOAT "F", adjust based on application losses. Refer Page 3 for different EQ, FG and SW settings.
TX AC Coupling Capacitors	220 nF nominal, 75 nF to 265 nF, see Figure 4
RX AC Coupling Capacitors	330 – 470 nF nominal, see Figure 4
R _{ext}	68 kΩ ± 5%
RX Pull Down Resistors at Receptacle	200 kΩ to 220 kΩ
Power Supply Capacitors	100 nF to GND close to each Vcc pin, and 22 uF to GND on the Vcc plane
Trace loss of FR4 before NB7NPQ7022M	Up to 13 dB losses
Trace loss of FR4 after NB7NPQ7022M	Up To 3 dB losses. Keep as short as possible for best performance.
DC Flat Gain Options	-3 dB, -1.5 dB, 0 dB, 2 dB
Equalization Options	6.7 to 13.1 dB
Swing Options	800 to 1200 mV
Differential Trace Impedance	90 Ω ± 10%

Typical Layout Practices

- RX and TX pairs should maintain as close to a 90 Ω Differential impedance as possible.
- Limit the number of vias used on each data line. It is suggested that 2 or fewer are used.
- Traces should be routed as straight and symmetric as possible.
- RX and TX differential pairs should always be placed and routed on the same layer directly above a ground plane. This will help reduce EMI and noise on the data lines.
- Routing angles should be obtuse angles and kept to 135 degrees or larger.
- To minimize crosstalk, TX and RX data lines should be kept away from other high speed signals.

NB7NPQ1002M

PACKAGE DIMENSIONS

WQFN30 2.50x4.50, 0.4P
CASE 510CK
ISSUE B

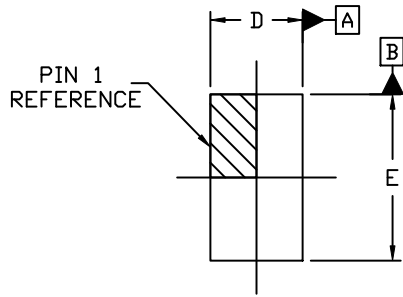

TOP VIEW

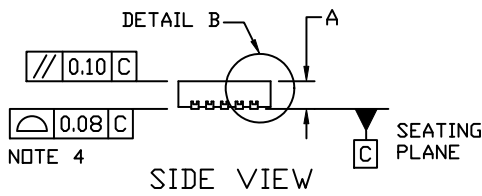

SIDE VIEW

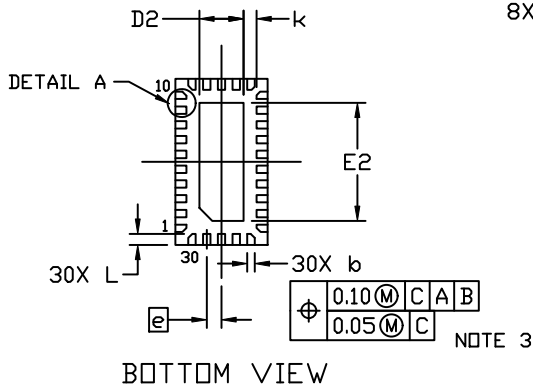

BOTTOM VIEW

NOTES:

1. DIMENSIONING AND TOLERANCING PER ASME Y14.5M, 1994.
2. CONTROLLING DIMENSION: MILLIMETERS
3. DIMENSION b APPLIES TO PLATED TERMINAL AND IS MEASURED BETWEEN 0.15 AND 0.30 MM FROM THE TERMINAL TIP.
4. COPLANARITY APPLIES TO THE EXPOSED PAD AS WELL AS THE TERMINALS.

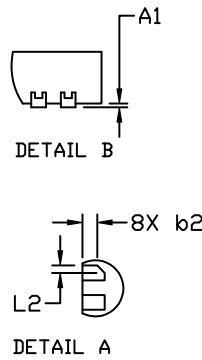

DIM	MILLIMETERS		
	MIN.	NOM.	MAX.
A	0.70	0.75	0.80
A1	---	---	0.05
b	0.15	0.20	0.25
b2	0.20 REF		
D	2.40	2.50	2.60
D2	1.15	1.20	1.25
E	4.40	4.50	4.60
E2	3.15	3.20	3.25
e	0.40 BSC		
K	0.20 REF		
L	0.25	0.30	0.35
L2	0.10 REF		

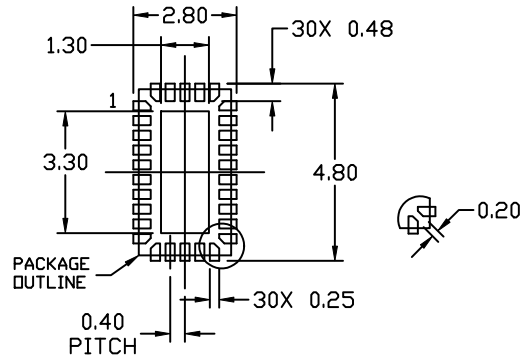

RECOMMENDED MOUNTING FOOTPRINT