

Overview

KEMET's Langevin-type transducers are used wherever powerful ultrasonic waves must be generated. For application flexibility and ease of installation, these transducers are mounted in a structure that can be bolted virtually anywhere.

KEMET's high-performance ceramic material NEPEC® N-61 is excellent for use in these Langevin transducers. KEMET produces a number of this type of transducers, all featuring high quality and excellent output levels, and all based on a unique proprietary design.

Applications

- Cleaning equipment
- Ultrasonic treatment machines
- Welders for plastic

Benefits

- High mechanical Q and excellent electro-acoustic conversion efficiency, providing a high output amplitude
- High speed of vibration due to piezoelectric element
- Fast and easy installation
- High reliability
- Operating temperature range from -40°C to +120°C
- Good amplitude linearity due to N-61 ceramics' extended temperature range
- RoHS/REACH compliant



Ordering Information

NBL	45	28	2	H	A	3
Series	Diameter of Acoustic Wave Radiation	Resonant Frequency	Number of Piezoelectric Elements	Construction Type	Radiation Surface	Model Type
NBL	15 = \varnothing 15 mm 20 = \varnothing 20 mm 45 = \varnothing 45 mm	28 = 28 kHz 40 = 40.2 kHz 60 = 60 kHz	2 = 2 elements	H = Horn construction (output surface has step or horn shape) S = Straight construction	Blank = Not available for treatment machines type A = Threaded type for cleaning equipment	Blank 3

Dimensions in mm

NBL45282H-A3

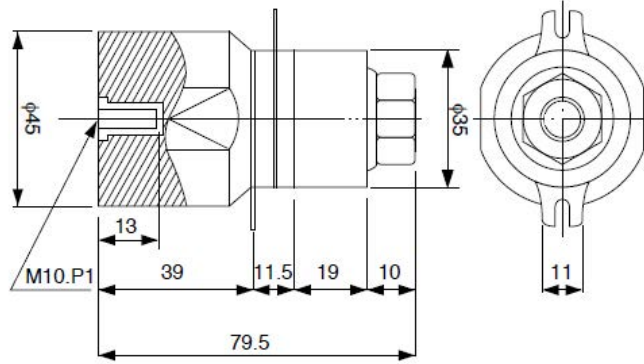

NBL45402H-A

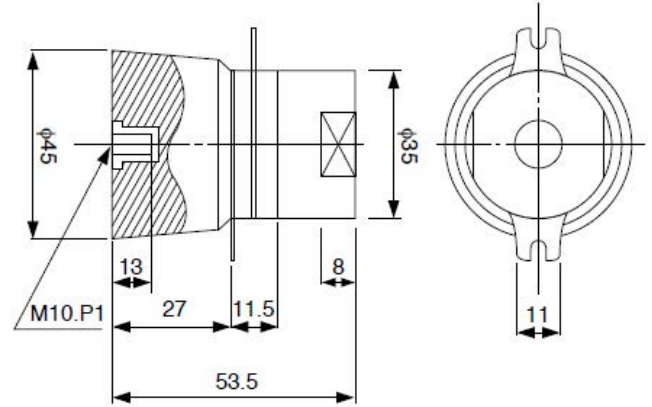

NBL15602S

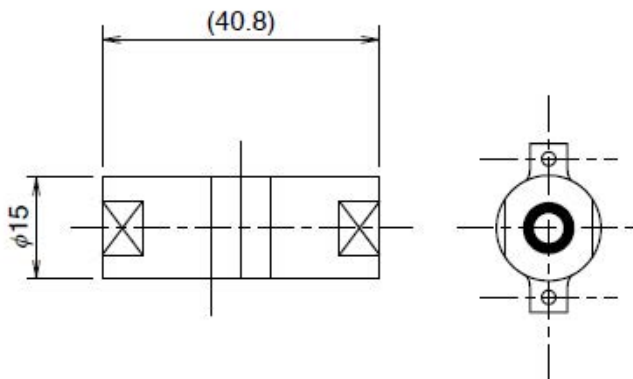

NBL20602S

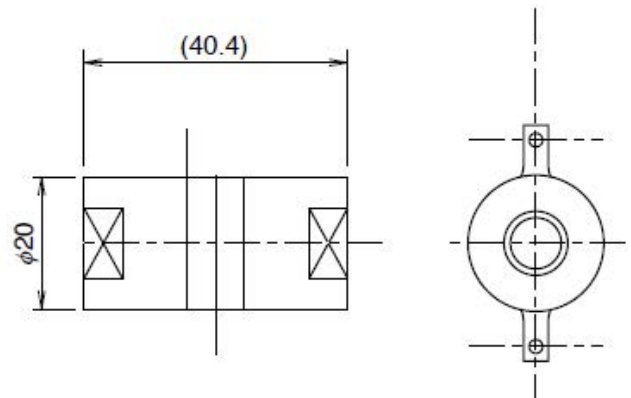

Environmental Compliance

All KEMET Piezoelectric Transducers are RoHS and REACH compliant.

Article 33(1) of the REACH Regulation states that manufacturers and importers of articles (products) are required to notify their customers of the presence of any Substances of Very High Concern (SVHC) in their products exceeding 0.1% by weight and provide instructions on safe use of the product.

KEMET Corporation reports regarding the Article 33(1) of REACH Regulation as follows:

1. Applicable Product:

Piezoelectric transducers (NBL Series).

2. Report for content of REACH SVHC list:

The product(s) above contain a substance by more than 0.1wt% per product weight that was published in the 8th update of the REACH SVHC substances (December 19, 2012).

3. Regarding safety of the piezoelectric transducers (Piezoceramic products):

The Piezoceramic that is used in this product becomes ceramic by sintering powder containing PZT as a main ingredient. It is chemically stable, with minimum risks toward the human body or environment within the intended use of the product. Please note that risks could occur in the case of inhalation or accidental oral uptake of powder ceramics.

4. Technical product information on the piezoelectric transducers (Piezoceramic products):

The manufacturing technique of the “piezoceramic products” whose main ingredient is Lead Titanium Zirconium Oxide (PZT) has been established, and there is no alternative material that can exhibit superior performance than PZT at this moment. Please note that the piezoceramic is listed as an exempt on RoHS (2011/65/EU) Annex III (7c.1).

5. Responsibility of piezoceramic manufacturers:

Piezoceramic manufacturers report information regarding PZT containment in their products to the customers to obey the article 33 of the REACH regulation.



Performance Characteristics

Item	Performance Characteristics
Operating Temperature Range	-40 to +120°C
Recommended Storage Condition	-20 to +80°C
Resonant Frequency Range	28 – 60 kHz
Maximum Allowable Power Range	2.5 – 50.0 W

Table 1 – Ratings & Part Number Reference

Part Number	Resonant Frequency (kHz)	Dynamic Admittance (mS)	Mechanical Q	Static Capacitance (pF)	Maximum Allowable Velocity (cm/S)	Maximum Allowable Power (W)	Application	Horn Plate	Backing Plate	Weight (g)
NBL45282H-A3	28.0	40	500	4,000	40	50 ¹	Cleaning equipment	Aluminium	Stainless Steel	400
NBL45402H-A	40.2	15	500	4,000	50	50 ¹	Cleaning equipment	Aluminium	Stainless Steel	240
NBL15602S	60.0	25	500	850	50	2.5 ²	Treatment machines	Aluminium	Aluminium	30
NBL20602S	60.0	20	400	1,250	40	3.7 ²	Treatment machines	Aluminium	Aluminium	35

¹ Maximum allowable power based on data where one unit is measured with a water load on one side.

² Maximum allowable input in no-load state.

Electrical Characteristics

Temperature Characteristics

NBL45282H-A3 & NBL45402H-A

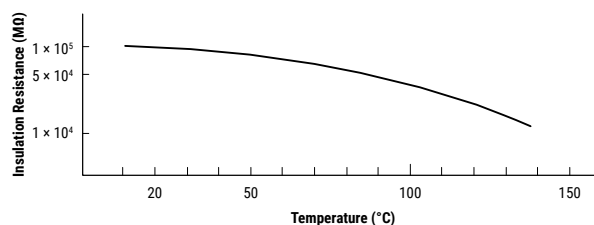
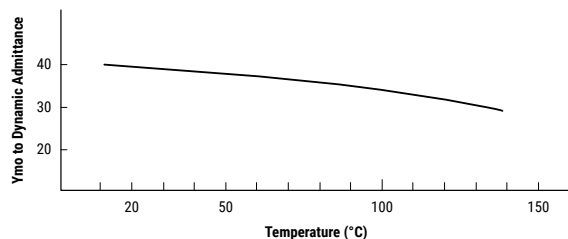
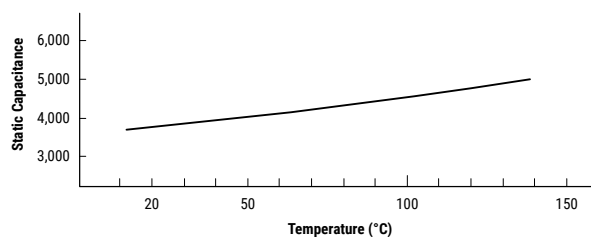
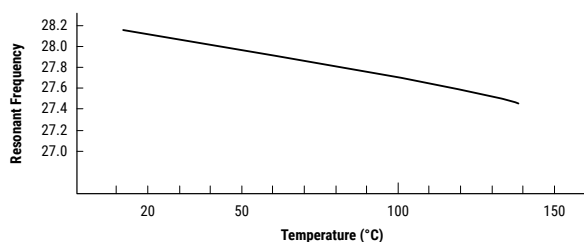

Electrical Characteristics cont.

Horn Installation Reference Example

NBL15602S

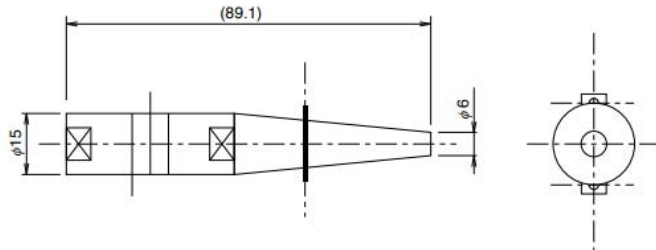

NBL20602S

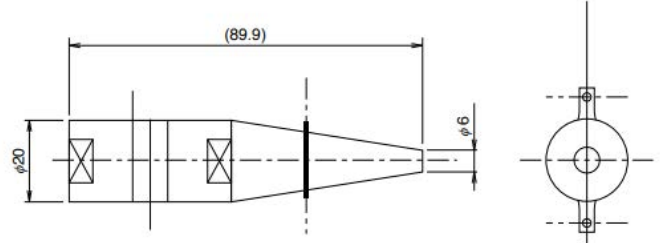

Vibration

NBL15602S

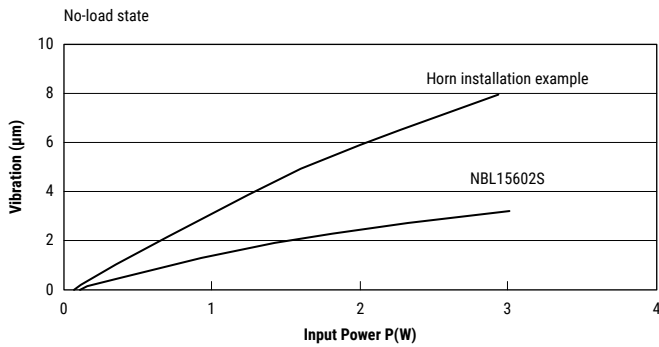

NBL20602S

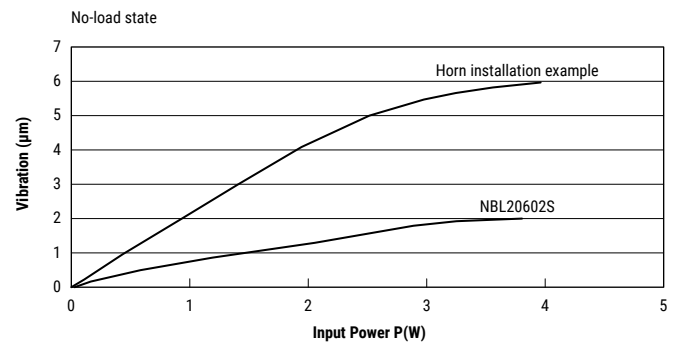

Packaging

Part Type	Packaging Type	Pieces per Box
NBL45282H-A3	Tray	30
NBL45402H-A		
NBL15602S		160
NBL20602S		

Handling Precautions

Precautions to be taken when using piezoelectric transducers (Please read these precautions before using our products)

Material selection, installation and activation of piezoelectric ceramics should be decided upon by users according to the applications. For proper evaluation and decision, products should be tested repeatedly in both realistic and abnormal operating conditions.

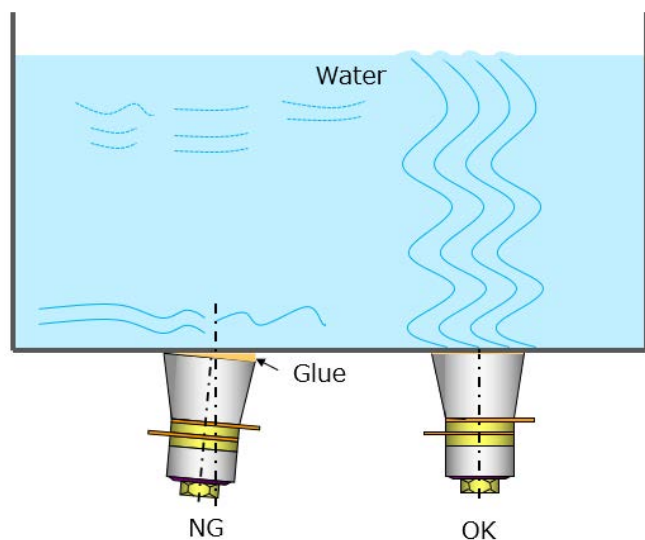

- Do not disassemble the product or remove the screw.
- Avoid excessive physical shock. Otherwise, the internal piezoelectric ceramic element may be damaged.
- Do not apply power exceeding its maximum allowance.
- Store the transducers preferably at ordinary temperatures (-20°C to +80°C). Avoid condensation on the product's surface.
- Handle products properly as industrial waste. When disposing, please contact your local waste disposal service and make sure the disposal methods meet all legal requirements.
- Transducers' stock should be used promptly, preferably within 1 year of receipt.

Export Control

For customers in Japan

For products which are controlled items subject to the "Foreign Exchange and Foreign Trade Law" of Japan, the export license specified by the law is required for export.

For customers outside Japan

Piezoelectric Transducers should not be used or sold for use in the development, production, stockpiling or utilization of any conventional weapons or mass-destructive weapons (nuclear weapons, chemical or biological weapons, or missiles), or any other weapons.