

NCN8026AMNGEVB

NCN8026A Evaluation Board User's Manual



ON Semiconductor®

<http://onsemi.com>

EVAL BOARD USER'S MANUAL

INTRODUCTION

This document gives a detailed description of the NCN8026A Evaluation Board (QFN-24) with the bill of materials (BOM), board schematic, and layout. The appropriate laboratory test setups are also provided. The NCN8026A Evaluation Board has been designed to help for a quick evaluation of the NCN8026A Smart Card Interface device.

This document has to be used with the NCN8026A datasheet. The datasheet contains full technical details regarding the NCN8026A specifications and operation. The board (FR4 material) is implemented in two metal layers. The top and bottom layers have thicknesses of 35 µm. The PCB thickness is 1.6 mm with dimensions of 89 mm by 68 mm (see Figure 1).



Figure 1. Evaluation Board

TEST EQUIPMENT

The following equipment listed in Table 1 is suggested for the evaluation.

Table 1. TEST EQUIPMENT

Description	Main Features	Example of Equipment (Note 1)	Qty.
Regulated Power Supply	200 mA DC current capability	Tektronix PS2520G	2
Multimeter		Keithley 2000 or 2001	2
Sourcemeeter		Keithley 2400	1
Oscilloscope	500 MHz bandwidth, four channel scope, minimum 1MB memory per channel (Note 2)	Tektronix TDS744, 754 or 784 / TDS5054 series or LeCroy WR5060, TDS5104B, 1 Ghz, 5 GS/s	1
Voltage probe	4 probes, 500MHz bandwidth	Tektronix or LeCroy	4
Waveform generator	Pattern generator	Agilent 81104A 80 MHz or HP8110A 150 MHz 2 outputs	1
SMB Cable			1

1. Equipment used in the context of this Evaluation Board User's Manual
2. Greater scope memory per channel offers better resolution

TEST PROCEDURE

Refer to Figure 2 for an overview of the main features of the evaluation board.

Initial Setup

The initial setup given here is recommended before starting measurements on the board.

- Set the CMDVCC/ in the OFF position (High).
- Set CS/ in the ON position: Chip selected, position Low.
- Set CLKDIV1 and CLKDIV2 into low position (lowest frequency f_{CLKIN})
- VSEL0 and VSEL1 are used to change the output CVCC (card power supply) or the smart card interface mode which can be 1.8 V, 3.0 V or 5.0 V. Change VSEL0 and VSEL1 using the switches (see Figure 2) according to Table 2 below. When VSEL0 = 0 then VSEL1 is in the mode 5 V / 3 Vbar, when VSEL0=1 then VSEL1 is in the mode 1.8 V / 3 Vbar. The initial setup can be VSEL0 = 0 and VSEL1 = 1 for selecting the 5 V mode. The CVCC output voltage can be changed on the fly when the smart card interface is active (/CMDVCC = Low). Nevertheless, it is recommended to change CVCC after having deactivated the device then reconfiguring CVCC by setting the appropriate VSEL0 and VSEL1 and reactivating the smart card interface.

Table 2. CVCC PROGRAMMING

VSEL0	VSEL1	CVCC
0	0	3.0 V
0	1	5.0 V
1	0	3.0 V
1	1	1.8 V

- As a precaution, if using the built-in resistive load, turn the 1 k Ω potentiometer to obtain a resistor output value of 1 k Ω , and then connect the jumper.

DC Power Supplies

Two power supplies are used to bias the demo board. VDDP is the input voltage of LDO Regulator. VDD is the “digital” power supply which biases the input stages of the NCN8026A device (control and signal inputs).

VDD and VDDP must be connected to the board to ensure correct operation. Connect the VDD and VDDP power supplies using the 2 pin male connectors J4 and J3

respectively. Refer to the recommended operating ranges for VDD and VDDP in the datasheet. Use VDD = VDDP = 5 V to get started.

Clock Frequency

CLKDIV1 and CLKDIV2 select the frequency divider for the card clock CCLK according to Table 3 given below.

Table 3. CVCC PROGRAMMING

CLKDIV1	CLKDIV2	CCLK Frequency
1	0	$f_{CLKIN} / 1$
1	1	$f_{CLKIN} / 2$
0	1	$f_{CLKIN} / 4$
0	0	$f_{CLKIN} / 8$

The Clock

The clock is applied externally (SMB connector). Refer to the datasheet for the recommended frequency and voltage levels that can be applied at CLKIN.

Card Presence

The typical socket is normally open, so PRES/ has been chosen; nevertheless the PRES and PRES/ test points can also be used for signaling the presence of a card and starting up the circuit. If not using a smart card, connect PRES/ to ground.

Start the measurement

To start the measurements, set the board as it follows:

1. Set CLKDIV1 and CLKDIV2 to select the correct frequency.
2. Set VSEL0 and VSEL1 to select the correct output voltage.
3. Check that the 1 k Ω potentiometer jumper is turned to 1 k Ω .
4. Set /CS low.
5. Set CMDVCC/ high.
6. Check that VDD and VDDP are set to 5 V, and set the current limit to 100 mA. Turn on the power supplies VDD and VDDP.
7. Toggle /CMDVCC from High to Low to start the device (activation sequence run).
8. Change the CVCC output voltage with the VSEL0 and VSEL1 switches.
9. Apply a clock to CLKIN and observe the card clock at CCLK. Use CLKDIV1 and CLKDIV2 to change the clock frequency.

NCN8026AMNGEVB

EVALUATION BOARD DESCRIPTION

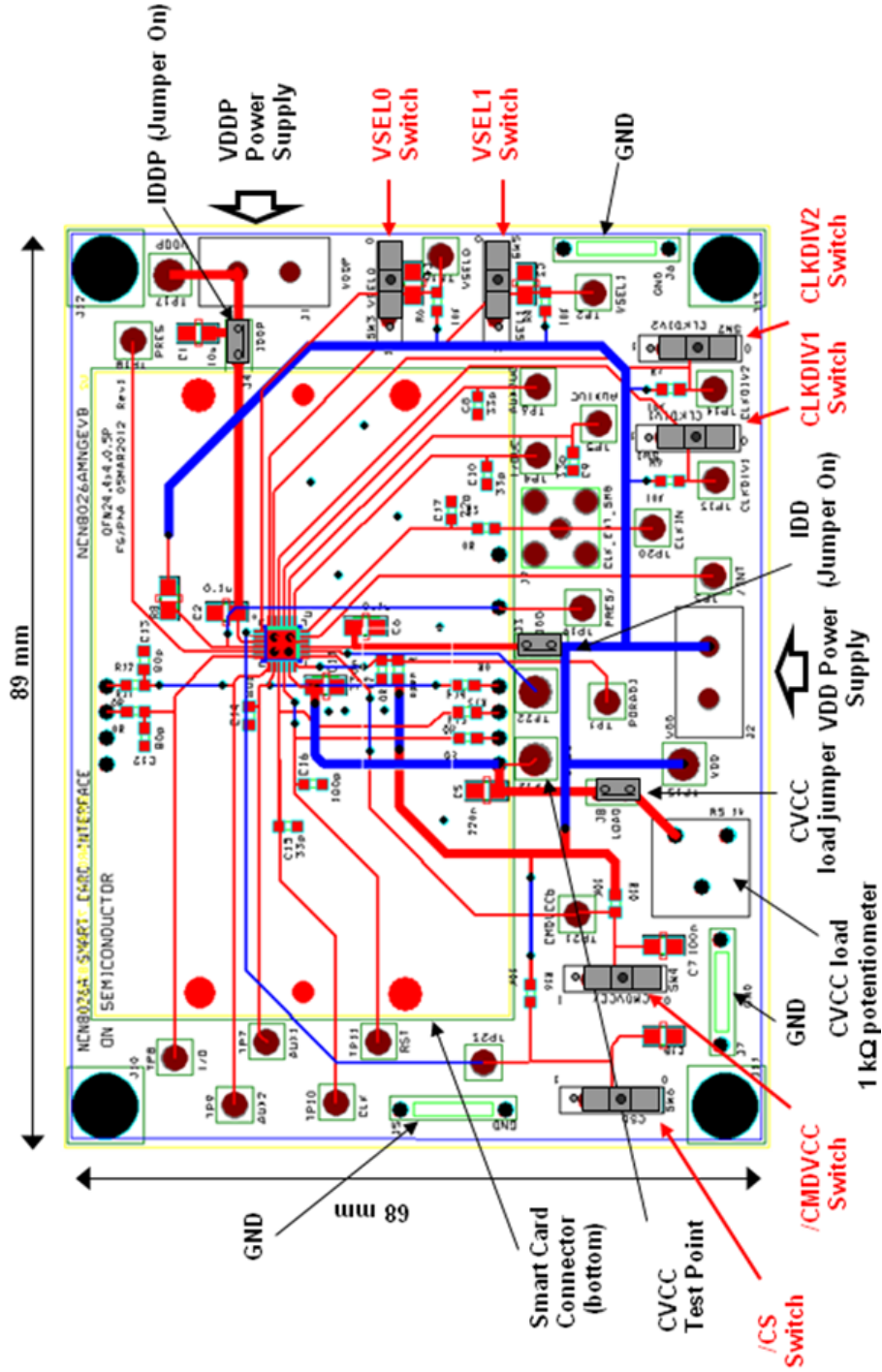

Figure 2. Board Description

NCN8026AMNGEVB

EVALUATION BOARD SCHEMATIC

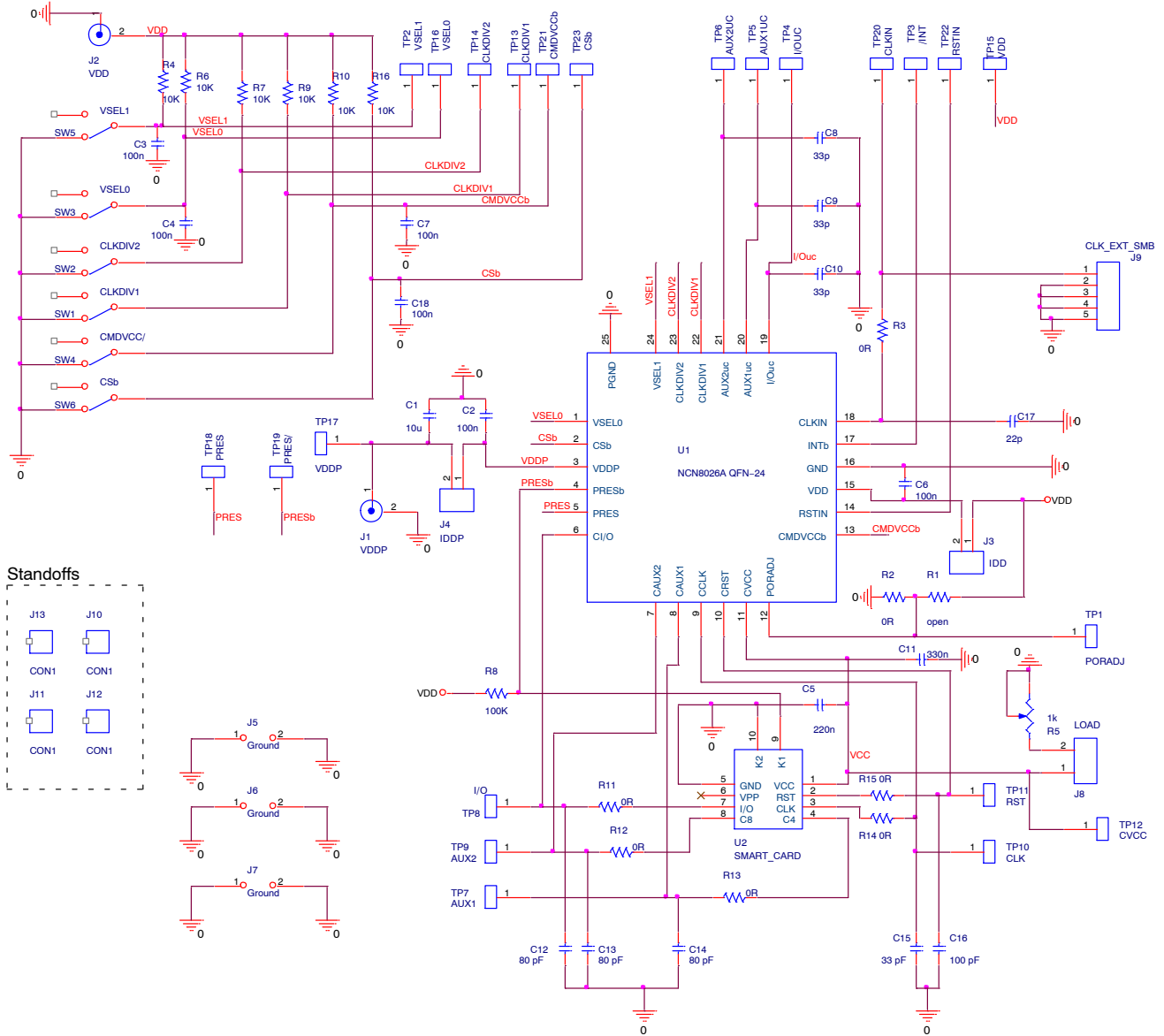

Figure 3. Board Schematic

NCN8026AMNGEVB

BILL OF MATERIALS – NCN8026A EVALUATION BOARD

Table 4. BILL OF MATERIALS

Designator	Qty	Description	Value	Tol	Footprint	Manufacturer	Manufacturer Part #	Lead Free
C1	1	CAP CER 10 UF 6.3 V 20% X5R 0805	10 uF	20%	0805	Murata	GRM21BR60J106ME19L	Yes
C2, C6, C7, C18	3	CAP CER .1 UF 25 V 10% X7R 0805	100 nF	10%	0805	Murata	GRM21BR71E104KA01L	Yes
C3, C4	2	CAP CER .1 UF 25 V 10% X7R 0603	100 nF	10%	0603	Murata	GRM188R71E104KA01	Yes
C5	1	CAP CER .22 UF 16 V X7R 10% 0805	220 nF	10%	0805	TDK Corporation	C2012X7R1C224K	Yes
C8, C9, C10, C15	4	CAP CER 33 PF 16 V X7R 0603	33 pF	5%	0603	AVX Corporation	Do not populate	Yes
C11	1	CAP CER .33 UF 16 V X7R 10% 0805	330 nF	10%	0805	TDK Corporation	C2012X7R1C334K/1.25	Yes
C12, C13, C14	3	Do not populate	80 pF	-	0603	Do not populate	Do not populate	-
C16	1	Do not populate	100 pF	-	0603	Do not populate	Do not populate	-
C17	1	CAP CERAMIC 22 PF 50 V NP0 0603	22 pF	5%	0603	Yageo	CC0603JRNP09BN220	Yes
R1	1	Do not populate	Open	-	0805	Do not populate	Do not populate	-
R2, R3, R11, R12, R13, R14, R15	7	RES 0.0 OHM 1/8 W 0603 SMD	0R	-	0603	Stackpole Electronics Inc	RMCF0805ZT0R00	Yes
R4, R6, R7, R9, R10, R16	5	CMS resistor 1%, 1/4 W	10k	1%	0603	Philips Components	232272461003	Yes
R5	1	Single turn Cermet trimmer, 1k, 0.5 W, 10%	1k	-	CERMET-72PT	Bourns	3386F-102LF-ND	Yes
R8	1	CMS resistor 1%, 1/4 W	100k	1%	0805	Philips Components	232272461004	Yes
SW1 to SW6	5	PCB slide switches	-	-	INTER3-2,54	EAO	09.03290.01	Yes
TP1 to TP11, TP13, TP14, TP16, TP18 to TP21, TP23	18	Clip Test Point, Hole Diameter 1.0 mm (0.040 mil)	-	-	TP_1.0MMHOLE_ KEYSTONE_5000	Keystone	5000	Yes
TP12, TP15, TP17, TP22	4	Clip Test Point, Hole Diameter 1.6 mm (0.063 mil)	-	-	TP_1.6MMHOLE_ KEYSTONE_5010	Keystone	5010	Yes
J1,J2	2	VDD, VDDP, 2-Pins Male Connector, 5.08 mm Step	-	-	MSTBA2	Phoenix Contact	MSTBA2.52G5.08	Yes
J3, J4, J8	3	IDD, IDDP, LOAD, Breakable Single Row Header (2 Pins)	-	-	CON2-2.54	TYCO Amp	5-826629-0	Yes
J5, J6, J7	3	Ground Strap, Brass, Diameter 1.0 mm, Pitch 10.16 mm, Height 9.9 mm	-	-	GND_STRP	HARWIN	D3082-46	Yes
J9	1	SMB connector	-	-	SMB/V	IMS	111510001	Yes
U1	1	NCN8026A Smart Card Interface	-	-	QFN 24 4X4 ENGINEERING	ON Semiconductor	NCN8026AMNTXG	Yes
U2	1	Smart card socket	-	-	SMARTCARD_FC I_74343L0825S01	FCI	7434L0825S01LF	Yes
none	4	Standoff nut	-	-	STANDOFF HOLE	Keystone Electronics	1903C	Yes
none	4	Standoff screw	-	-	STANDOFF HOLE	Keystone Electronics	4814K-ND	Yes