

# NCN9252MUGEVB

## High-Speed USB 2.0 (480 Mbps) DP3T Switch for USB/UART/Data Multiplexing Evaluation Board User's Manual



ON Semiconductor®

<http://onsemi.com>

### EVAL BOARD USER'S MANUAL

#### OVERVIEW

The NCN9252 is a DP3T switch for combined UART and USB 2.0 high-speed data applications. It allows portable systems to use a single external port to transmit and receive signals to and from three separate locations within the portable system. It is comprised of two switches, each with a single common I/O that alternates between three terminals. They are operated together to allow three data sources, such as a USB or UART transceiver, to pass differential data through a shared USB connector port.

The NCN9252 features low RON— 4  $\Omega$  (max) at 4.2 V  $V_{CC}$ , 5  $\Omega$  (typ) at a 3.3 V  $V_{CC}$ . It also features low CON,

< 30 pF (max) across the supply voltage range. This performance makes it ideal for both USB full-speed and high-speed applications that require both low RON and CON for effective signal transmission. The NCN9252 is capable of accepting control input signals down to 1.4 V, over a range of  $V_{CC}$  supply voltages with minimal leakage current. The NCN9252 is offered in a Pb-Free, 12 pin, 1.7 x 2.0 x 0.5 mm, UQFN package.



Figure 1. Board Photo

## NCN9252MUGEVB

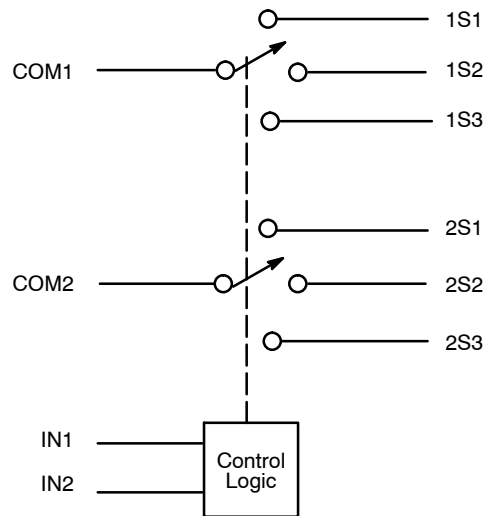

**Figure 2. Functional Block Diagram**

**Table 1. FUNCTION TABLE**

IN1 [0]	IN2 [1]	COM1 Closed to:	COM2 Closed to:
0	0	No Connect	No Connect
1	0	1S1	2S1
0	1	1S2	2S2
1	1	1S3	2S3

### Get Started...

#### Equipment needed

- Power Supply
- 2 Banana Cables
- Computer
- USB Flash Drive
- USB Cable

#### Procedure

1. Set the power supply to 3.3 V. Connect the power supply from  $V_{CC}$  to GND using the banana cables. The supply current should be less than  $1 \mu A$ .
2. Connect the USB drive to the common I/O USB port, J1.
3. Connect the USB cable from the desired output port to the computer
4. Select the output port by moving the jumpers to the appropriate logic level for IN1 and IN2, as shown in the function table in Table 1.

# NCN9252MUGEVB

## BOARD SCHEMATIC

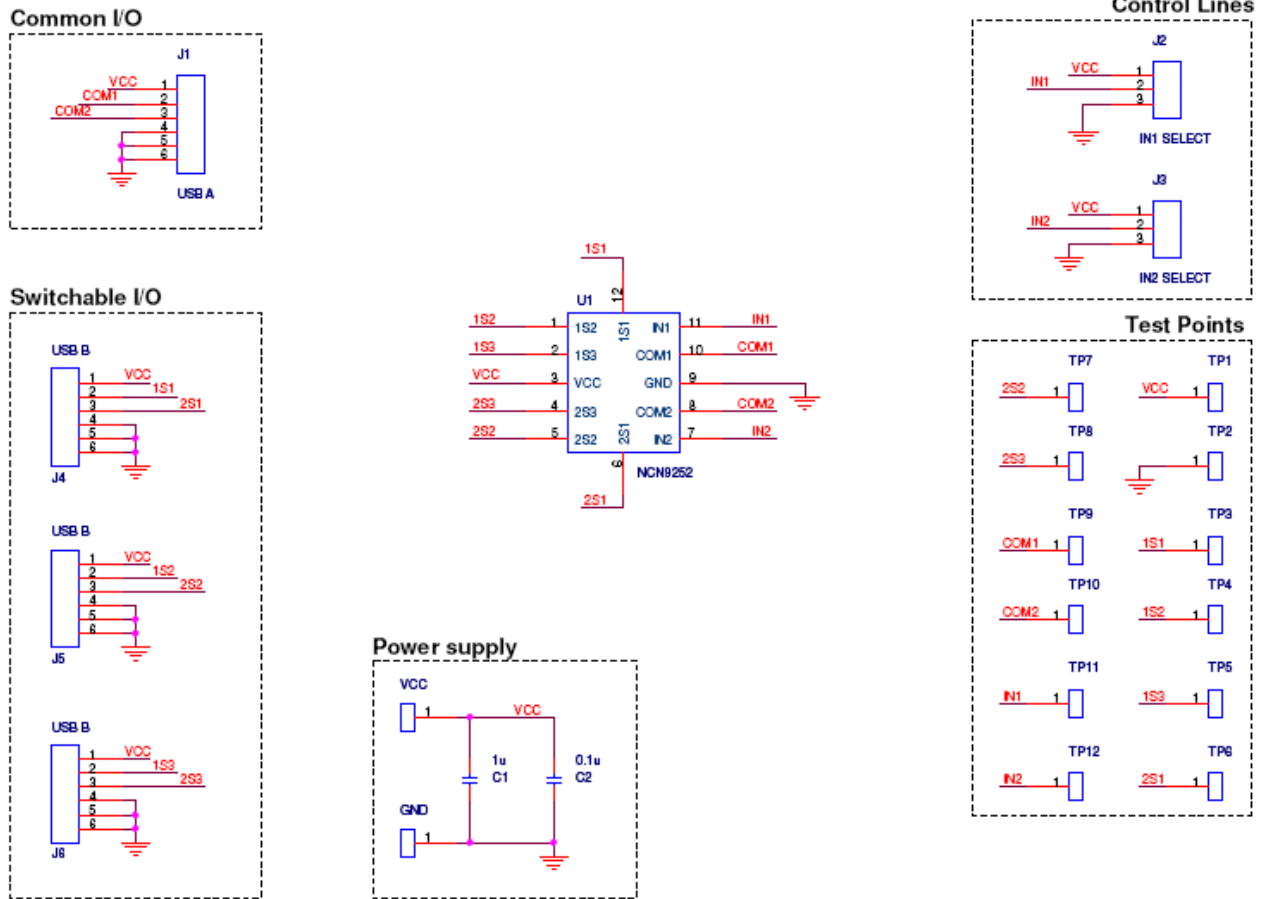

Figure 3. Board Schematic

Table 2. BILL OF MATERIALS

Designator	Qty	Description	Value	Tolerance	Footprint	Manufacturer	Manufacturer Part Number	Substitution Allowed	Lead Free
C1	1	Ceramic Capacitor SMD	1µF	10%	805	AVX Corporation	GRM155R60J105	Yes	Yes
C2	1	Ceramic Capacitor SMD	0.1µF	10%	603	AVX Corporation	0603YC104KAT2A	Yes	Yes
J1	1	USB TypeA connector surface mount	n/a	n/a	USB TypeA	Mill-Max	896-43-004-00-000000	Yes	Yes
J2, J3	2	3-pin header	n/a	n/a	Header3	Tyco Electronics	5-826629-0	Yes	Yes
J2, J4	2	2-pin jumper	n/a	n/a	n/a	Tyco Electronics	4-881545-2	Yes	Yes
J4, J5, J6	3	USB TypeB Connector through-hole	n/a	n/a	USB TypeB	Adam Tech	USB-B-S-RA	Yes	Yes
J7, J8	2	Banana Connector	n/a	n/a	7mm Hole	Johnson Components	111-2223-001	Yes	Yes
J9, J10, J11, J12	4	Standoff nut	n/a	n/a	n/a	Keystone Electronics	1903C	Yes	Yes
J9, J10, J11, J13	4	Standoff screw	n/a	n/a	n/a	Keystone Electronics	4814K-ND	Yes	Yes
TP1, TP3, TP4, TP5, TP6, TP7, TP8, TP9, TP10, TP11, TP12	11	Test Point PC Multi Purpose	n/a	n/a	1mm hole	Keystone Electronics	5000	Yes	Yes
TP2	1	PCB shorting link	n/a	n/a	GND_Strap	Harwin	D3082-46	Yes	Yes
U1	1	NCN9252	n/a	n/a	UQFN12	ON Semiconductor	NCN9252MUTAG	No	Yes

# NCN9252MUGEVB

## PCB LAYOUT GUIDELINES

### Electrical Layout Considerations

Implementing a high speed USB device requires paying attention on USB lines and traces to preserve signal integrity. The demonstration board serves as a layout example and can support the design engineers to preserve high speed performances.

Electrical layout guidelines are:

- The bypass capacitor must be placed as close as possible to the V<sub>CC</sub> input pin for noise immunity.
- The characteristic impedance of each High Speed USB segment must be 45 Ω.

- The ground plane of the PCB will be used to determine the characteristic impedance of each line.
- All corresponding D+ / D- line segment pairs must be the same length.
- The use of vias to route these signals should be avoided when possible.
- The use of turns or bends to route these signal should be avoided when possible.

### EVALUATION BOARD PCB LAYOUT

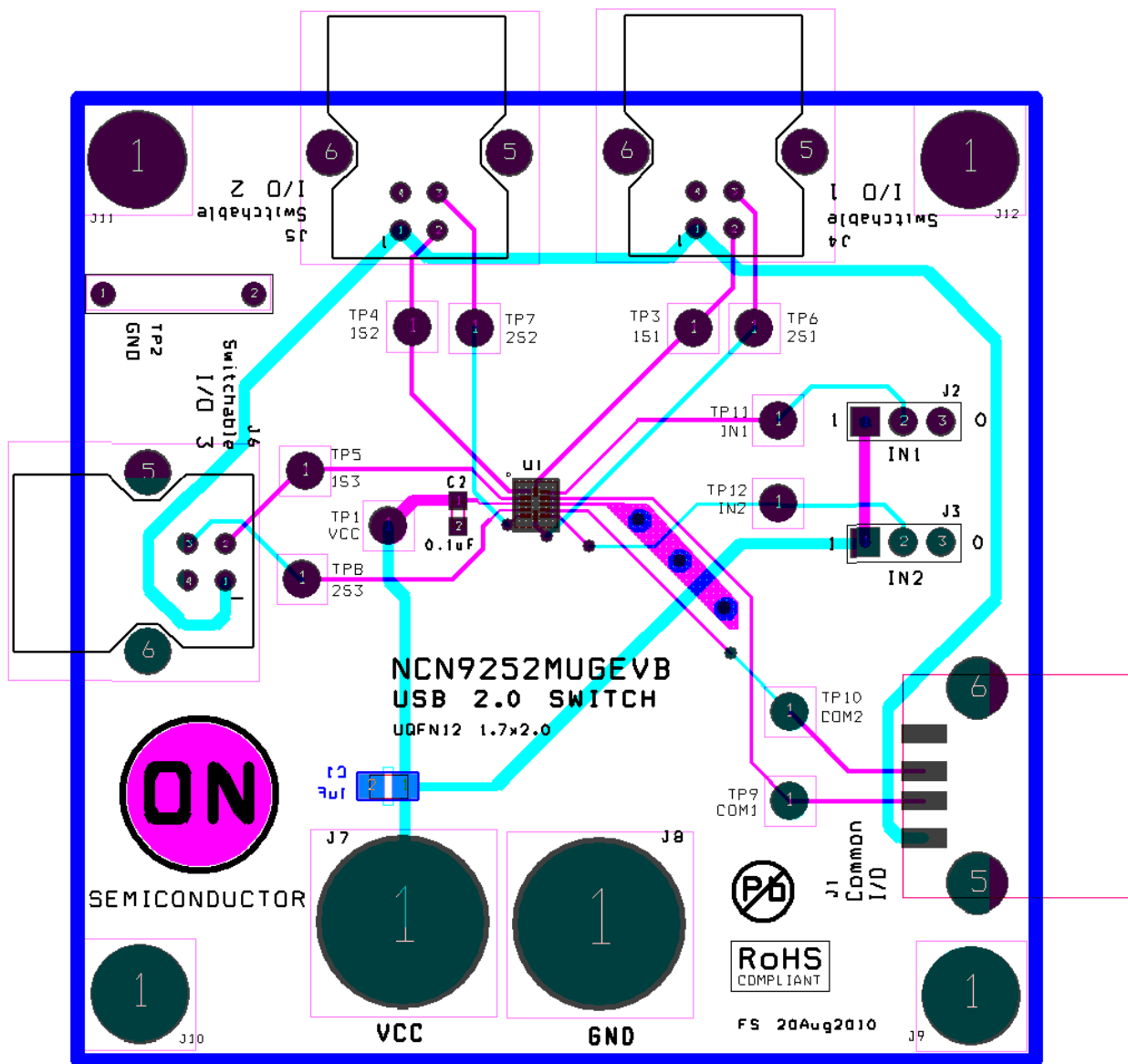

Figure 4. Evaluation Board Layout. Top Layer: Magenta. Bottom Layer: Cyan.