



## Test Procedure for the NCP1075SOTGEVB Evaluation Board

**Introduction:** The NCP1075 EVAL demo board is a universal input, off-line, 10 watt output, constant voltage power supply for powering E-meters or white goods applications. The output can be configured easily with a few component changes for 12V<sub>out</sub> or 5V<sub>out</sub>. The switching topology is a discontinuous mode flyback converter utilizing the ON Semi NCP1075 monolithic controller with internal MOSFET. The specific default demo board has an output rating of 12 volts at 0.8 amps max. Info for modification and testing for a 5V<sub>out</sub> board is below.

### Equipment Required:

1. Adjustable, isolated AC power source capable of zero to 265 Vac output up to 500 mA. AC source should have the capability of measuring input power in watts. If not, an AC line analyzer or AC wattmeter should be used. Wattmeter should be capable of reading down to 50 mW (for standby power measurements.)
2. Digital volt/amp meters to measure output current and voltage to the electronic load.
3. A variable electronic load or rheostat capable of up to a 3 amp load. If an electronic load is used it is preferable to have a constant resistance load mode. The current meter on the electronic load can be used in lieu of a series, in-line ammeter.
4. Oscilloscope with probe to monitor output ripple on the demo converter.



**Setup Procedure:** Set the equipment as shown in the diagram below so that the output voltage and current to the demo board can be measured and the output ripple can be monitored.

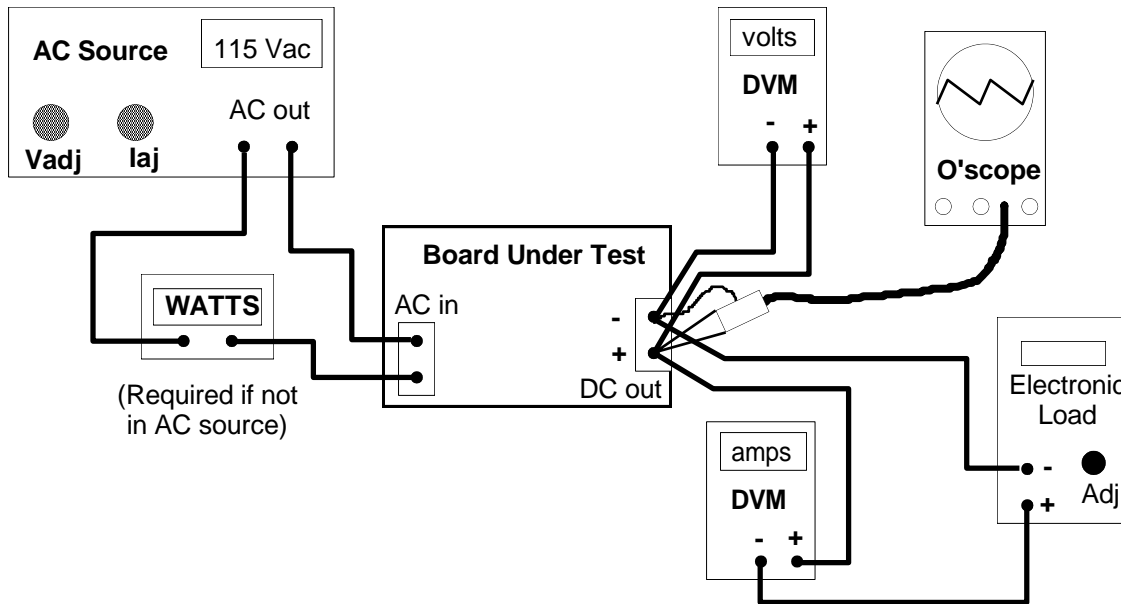

Note: Indicated output polarity on above drawing of demo board may not correspond to actual demo board. Please note output polarity as marked on demo board.

### Test Procedure:

1. Switch the electronic load on and set to zero load; switch all of the digital meters on (assuming they are wired properly for voltage and current sensing); turn the oscilloscope on with sensing in AC mode and 100 mV per division vertical and a sweep rate of 5  $\mu$ S per division. Connect the scope probe to the demo board's output terminals.
2. With the AC source OFF, set the current limit on the AC source to 250 mA and the output voltage to 120 Vac.
3. Turn on the AC source and the power supply output voltage should be 12 Vdc + 0.3 V, - 0.2V on the DVM (11.8 to 12.3 V is default output voltage setup for this demo board).
4. Adjust the electronic load from no load slowly up to 0.8A (full load). The output voltage should remain within 120 mV (1%) of nominal if properly regulating. The output ripple (switching frequency) on the oscilloscope should be less than 150 mV peak-to-peak at full load. (Note – scope probe tip should be decoupled with a