

NCP11187A65P45WGEVB



ON Semiconductor®

www.onsemi.com

45 W Auxiliary Power Supply for White Goods and Industrial Equipment with NCP11187A65

EVAL BOARD USER'S MANUAL

GENERAL SPECIFICATIONS

Devices	Applications	Topology	Output Power	Input Voltage	Output Spec.
NCP11187A65	White Goods and Industrial Power Supplies	Isolated Flyback	45 W	85–265 Vac	12 V/3.5 A & 16 V/0.2 A
Efficiency	Standby Power	Package Temperature	Operating Temperature	Cooling Method	Board Size
> 88% @ Full-load	< 50 mW @ 230 Vac	90°C	0–50°C	Natural Convection In Open Frame	145 x 60 x 30 mm 2.83 W/inch ³

Description

This user's manual introduces not only performance of a reference design with 45 W isolated flyback converter using NCP11187 for auxiliary power supplies but also provides key experimental results and information.

NCP1118x is a highly enhanced switcher integrating a peak current mode PWM controller employing mWSaver™ and frequency reduction technology and a highly robust 800 V Super-junction II MOSFET. Additionally, it features a high-voltage startup circuit, frequency reduction, slope compensation, constant output power limit, and highly reliable and various protections. As a result, it allows designing cost-effective off-line power supplies using NCP1118x with less BOM counts and smaller PCB size and high efficiency as well. Additionally, it could get low standby power consumption less than typically 50 mW despite of multiple outputs.

On top of that, NCP1118x features variety of protections for highly reliable power supply design such as a feedback pin open-loop protection (OLP), current-sense resistor short protection (CSSP), brown-out, line over-voltage protection (Line-OVP) using an line voltage sensing pin operated with auto-recovery operation and constant over-power protection. This user's manual demonstrates those protections under various conditions.

Key Features

- Peak Current Mode Controller Integrated 800 V SJ-II MOSFET, High Voltage Start-up, Soft-Start, and Slope Compensation
- mWSaver Technology Provides Industry's Best-in-Class Standby Power
- Switching Frequency Option: 65/100/130 kHz
- Proprietary Asynchronous Frequency Hopping Technique for Low EMI
- Programmable Constant Output Power Limit for Entire Input Voltage Range
- Precise Brown-out Protection and Line Over-voltage Protection (LOVP) with Hysteresis
- Current Sense Short Protection (CSSP) and Abnormal Over-Current Protection (AOCP)
- Thermal Shutdown (TSD) with Hysteresis
- All Protections Operated by Auto-recovery: VCC Under-voltage Lockout (UVLO), Feedback Open-Loop Protection (OLP), VCC Over-Voltage Protection (OVP)

NCP11187A65P45WGEVB

REFERENCE BOARD SCHEMATIC & DESCRIPTION

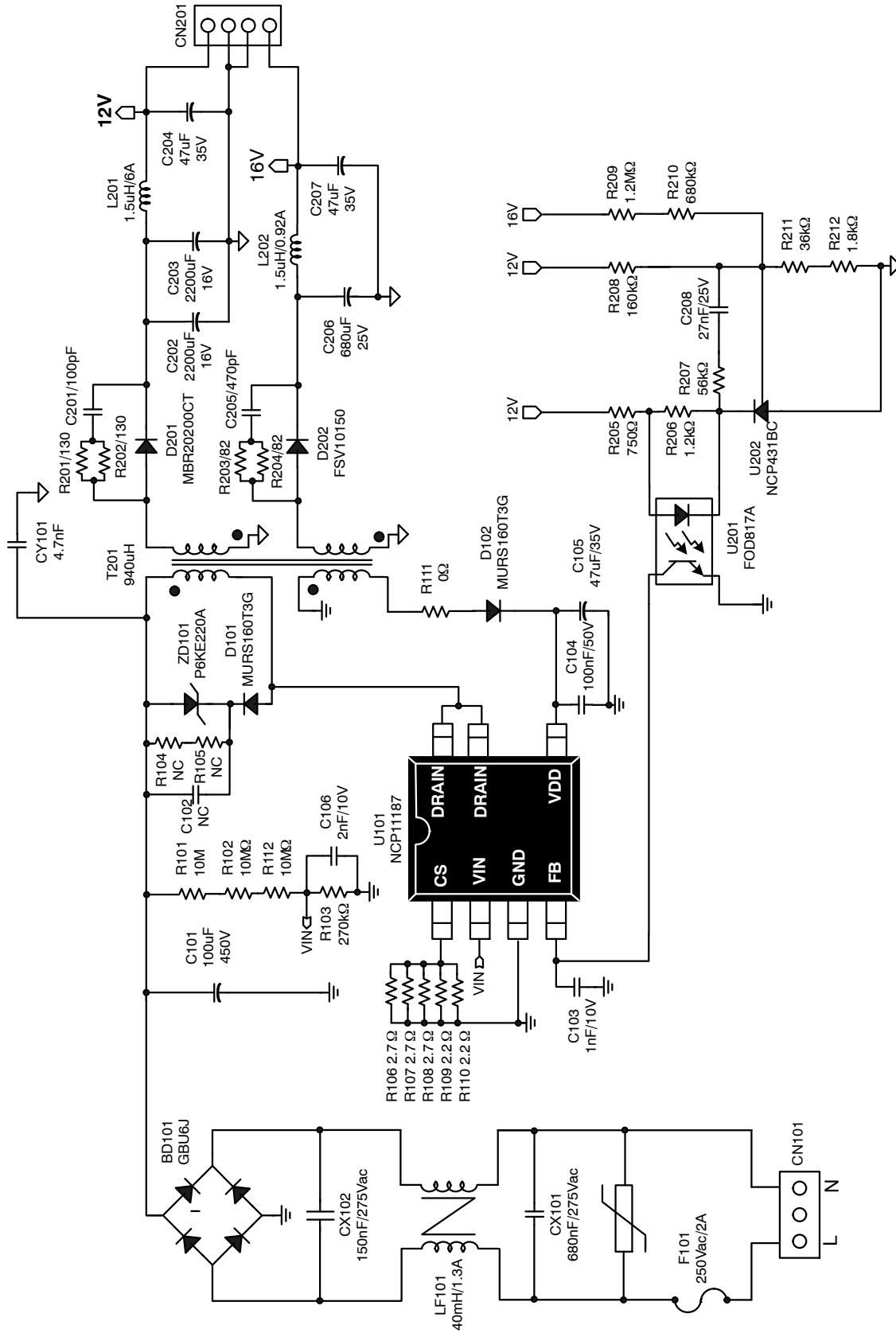

Figure 1. Reference Board Schematic

NCP11187A65P45WGEVB

This reference board comprises four parts overall, EMI filter, primary side control, secondary output and feedback circuit part. For more detail, these parts could be described as following.

1. *EMI filter* is formed by components of a common-mode filter LF101, X-capacitors CX101 and CX102, and Y-capacitor CY101.
2. *Primary side control part* in flyback converter consists of NCP11187 switcher U101, a power transformer T201, a bulk capacitor C101, a full-wave rectifier BD101, a snubber circuit ZD101 and D101 and line input voltage sensing R101~R103, R112 and C106. Additionally, V_{CC} bias is powered for from the auxiliary winding of T201 and related components of D102, C104 and C105 during normal operations. The resistor array of R106~R110 is for drain current sensing resistor and connected to CS pin. The sensed drain current is used in peak current mode control and some protections e.g. pulse-by-pulse current limit, AOCP (Abnormal Over-current Limit) and CSSP (Current-sensing Short Protection) and etc. In this reference board, TVS (Transient Voltage Suppressor) is utilized for a snubber to suppress voltage spike produced by leakage inductance at MOSFET turn-off. Optionally, RCD snubber can be used since component places of R104, R105 and C102 is already assigned, if needed. Meanwhile, C106 is used to decouple high frequency switching noise from line sensing signals. It is typically 1 nF~3.3 nF in this sensing method, but should be adjusted considering real noises in an actual experiment.
3. *Secondary side output stage* has two output terminals (12 V/3.5 A and 16 V/0.2 A) and associated components such as output diodes D201, D202, output capacitors C202~C204, C206, C207 with filter inductors L201, L202, and RC snubber R201, C201, R203, C205 for the output diodes. The output capacitors and filter inductors are formed as pi-type filter to reduce output voltage ripple while rejecting high frequency switching noise.
4. *Feedback circuit at the secondary side* employs dual feedback circuit with two poles & one zero to increase feedback loop response and reduce voltage variation on the unregulated output voltage caused by cross-regulation depending on load variation. Main regulated output is 12 V-output through feedback circuits of resistors R208, R211, R212 and R205, a voltage reference U202 and an opto-coupler U201. The 16 V-output voltage can be also sensed and affect feedback loop with low weight through R209 and R210. R207 and C208 provides one pole and zero and should be adjusted considering feedback response in an actual experiment.

NCP11187A65P45WGEVB

PCB LAYOUT

The PCB is composed of bottom side single layer with FR4 and 1 oz. copper cladding.

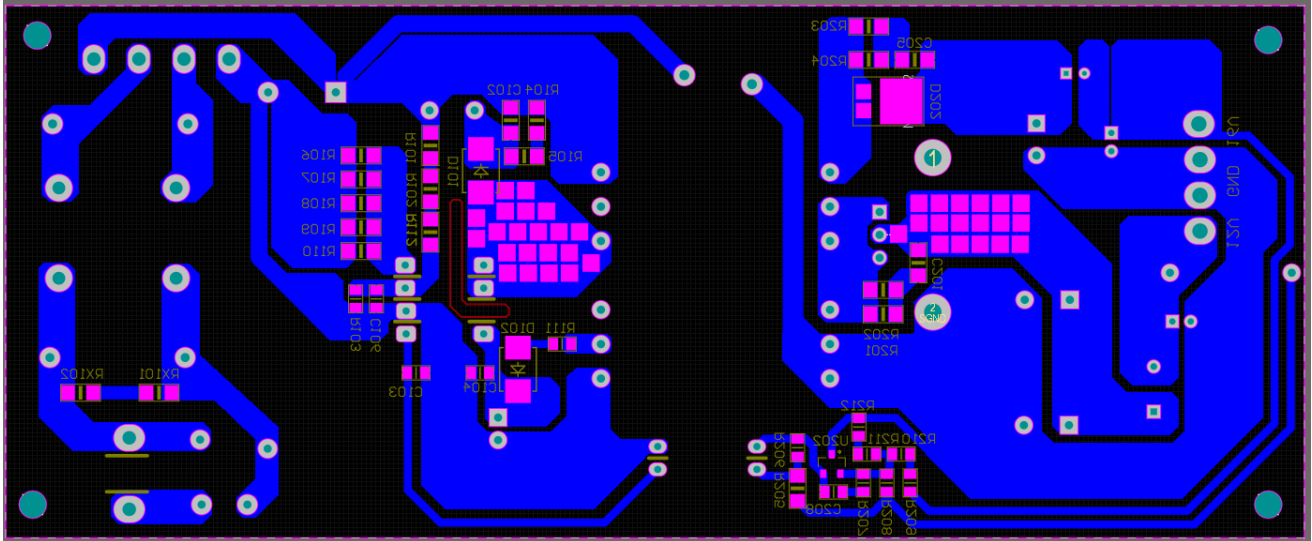

Figure 2. PCB Bottom Side Layer and Silk Screen

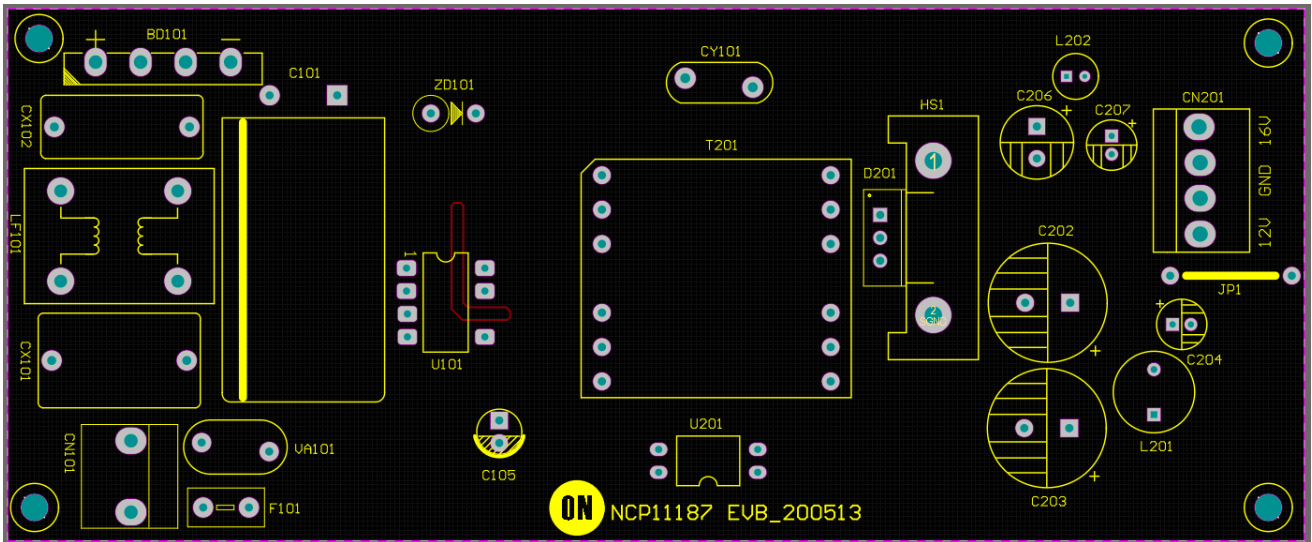

Figure 3. Top Side Silk Screen of the PCB

NCP11187A65P45WGEVB

PHOTOGRAPH OF REFERENCE BOARD

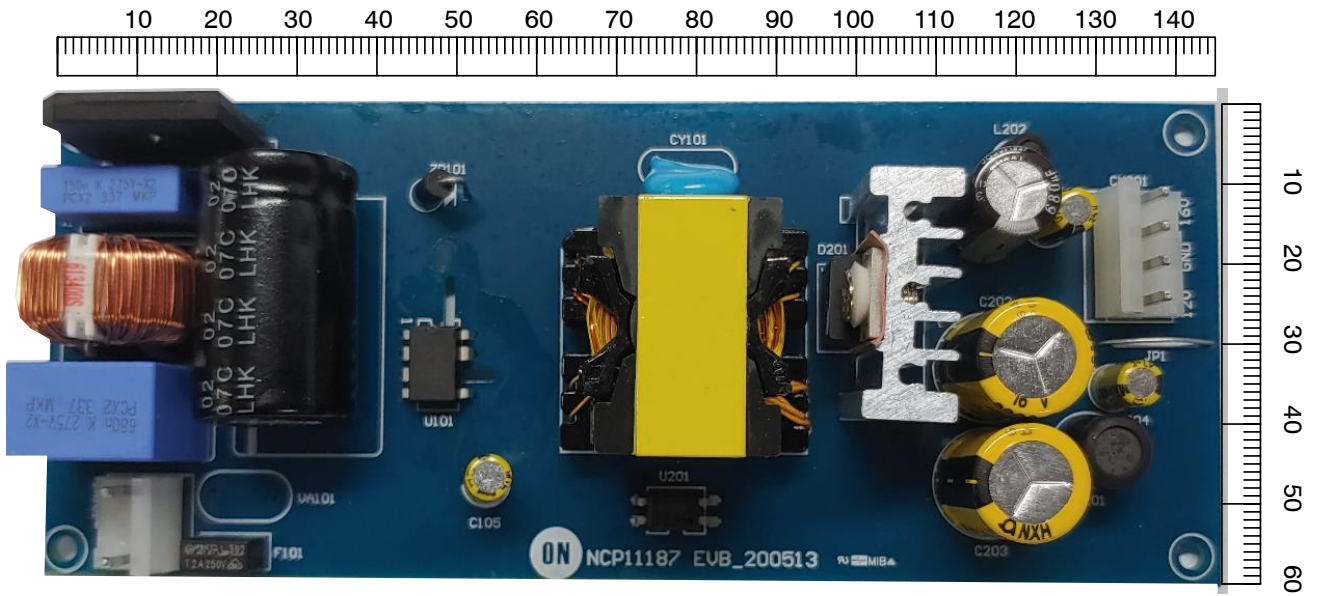

Figure 4. Photograph of Reference Board (Top)

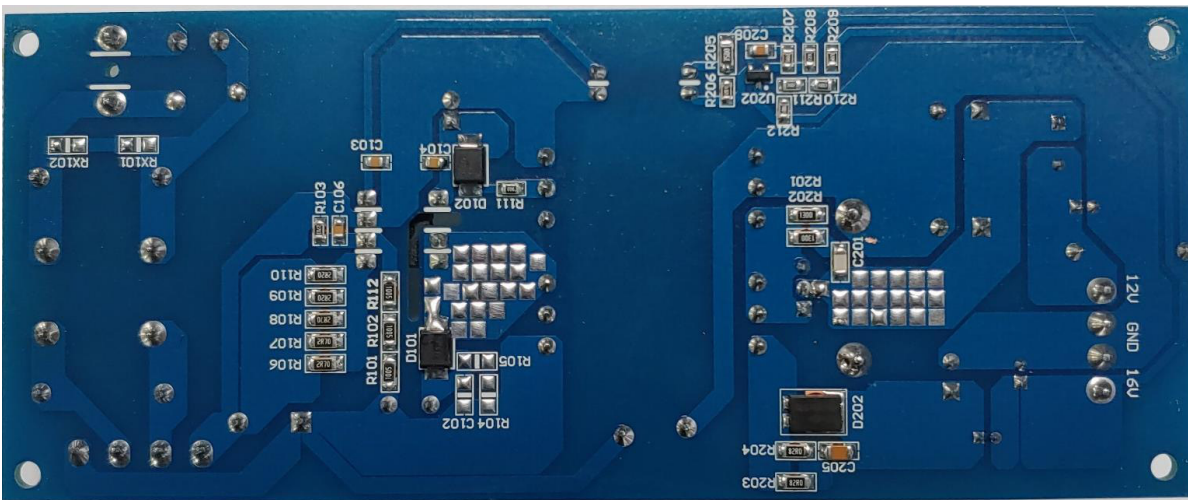

Figure 5. Photograph of Reference Board (Bottom)

NCP11187A65P45WGEVB

TRANSFORMER SPECIFICATION

- Transformer Overall Specification

	Value	Note
Core	PQ2625	TDK
Bobbin	PQ2625 bobbin	SUMMITOMO BAKELITE CO LTD
Primary-side inductance	940 μ H (typ)	Measure pin 1 to 3 @ 100 kHz & 1 V
Leakage inductance	6 μ H	Short all pin except primary-side winding

- Transformer Overall Specification

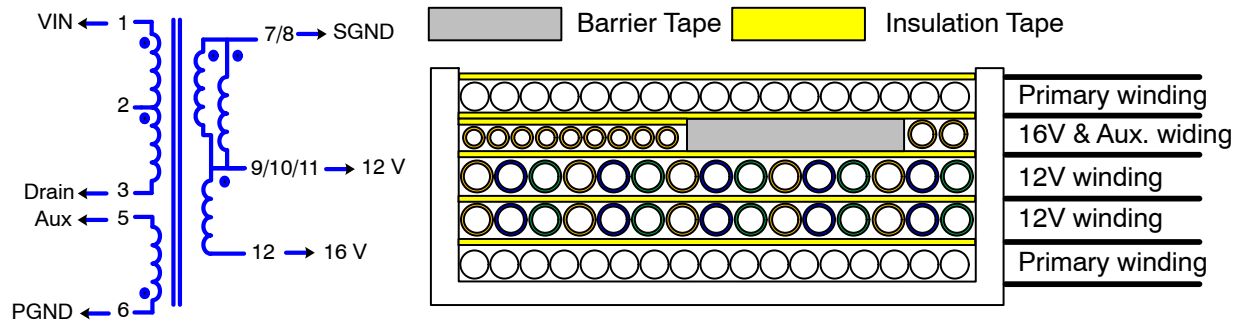

Figure 6. Transformer Specification

- Transformer Winding Method

Order	Winding Name	Wire - Diameter	Number of Strands	Start - Finish	Turns	Insulation Tape Turns
1	N_p	UEW - ϕ 0.45	1	1-2	24	1 ^{TS}
2	N_{12V}	TIW - ϕ 0.4	3	7-9	7	1 ^{IS}
3	N_{12V}	TIW - ϕ 0.4	3	8-10	7	1 ^{IS}
4	N_{16V}	TIW - ϕ 0.25	1	11-12	2	1 ^{IS}
5	N_{Aux}	TIW - ϕ 0.2	1	6-5	8	1 ^{IS}
6	N_p	UEW - ϕ 0.45	1	2-3	24	1 ^{IS}

NCP11187A65P45WGEVB

STANDBY POWER

1. STBY @ No Load

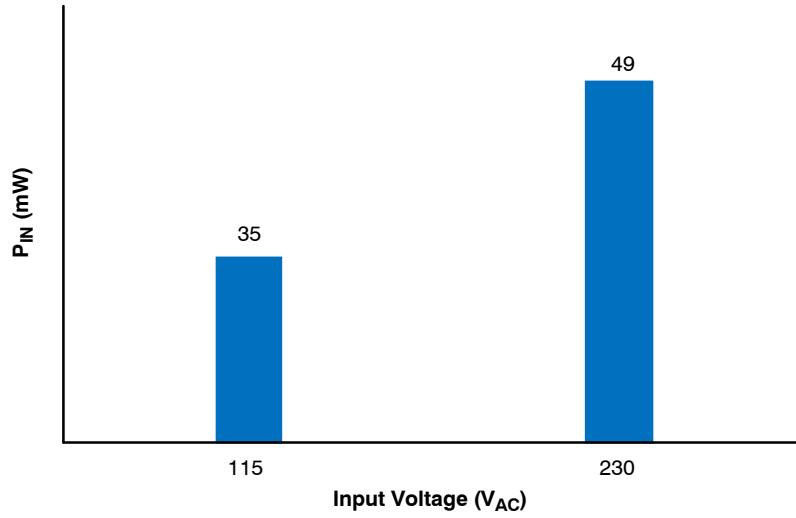

Figure 7. No Load Power Consumption

2. STBY @ Load Variation from 0.5 W to 10 W

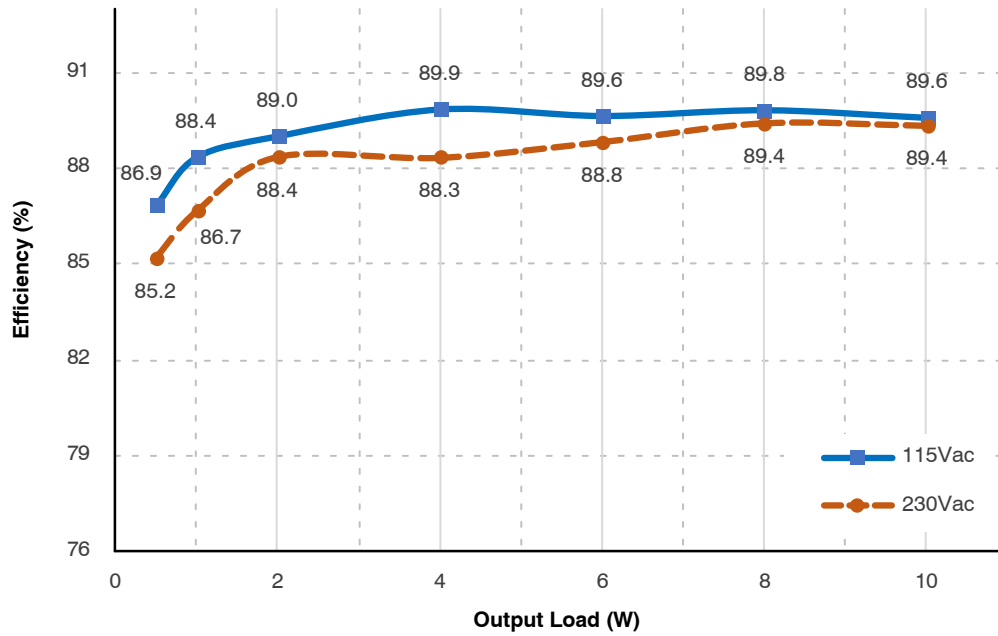

Figure 8. Stand-by Power at Light Load Condition

NCP11187A65P45WGEVB

EFFICIENCY

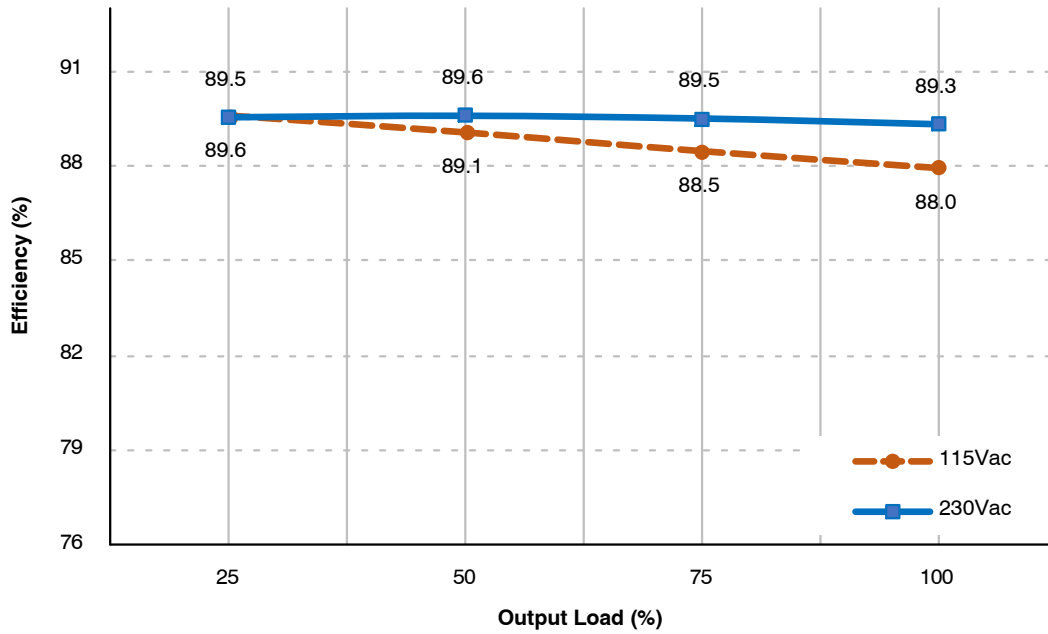

Figure 9. Efficiency at 4 Points Load

CONSTANT OVER-POWER LIMIT (COPL)

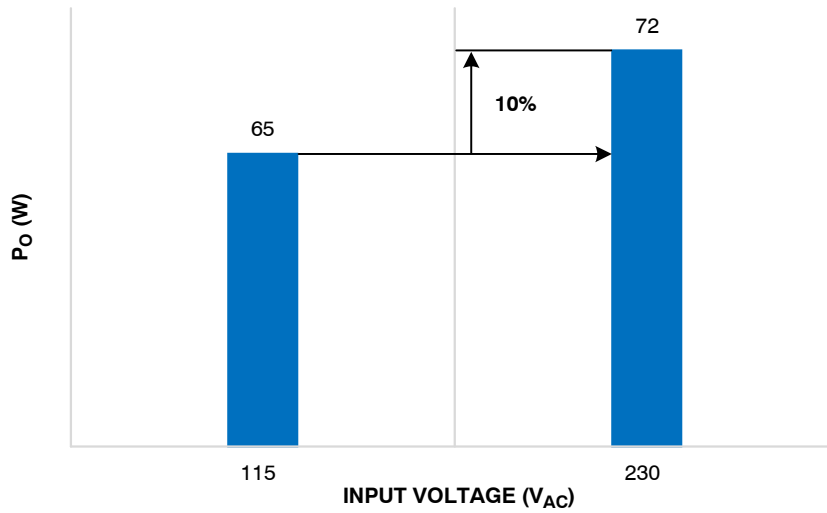

Figure 10. Over-Power-Limit Depending on Input Voltage

NCP11187A65P45WGEVB

TEMPERATURE OF COMPONENTS

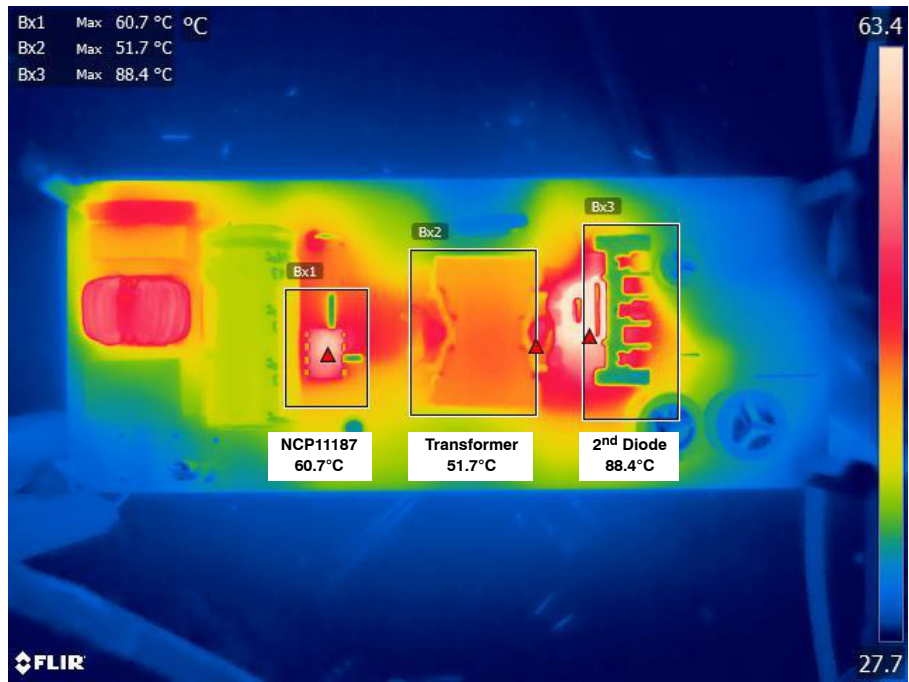

Figure 11. Temperature of the Reference Board @115 V_{AC}/60 Hz

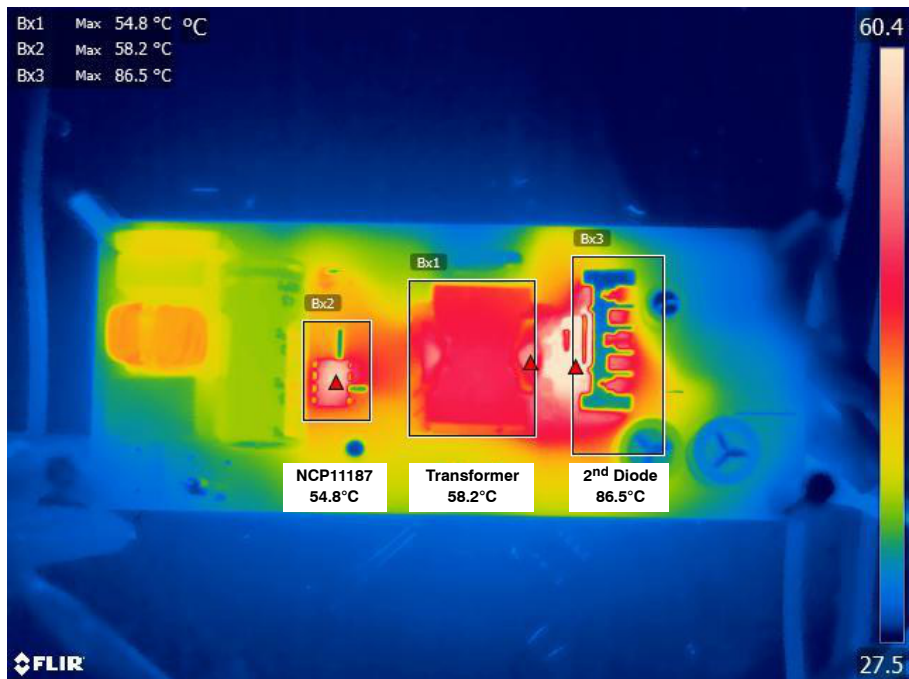

Figure 12. Temperature of the Reference Board @230 V_{AC}/60 Hz

NCP11187A65P45WGEVB

KEY OPERATIONS OF EVB

Nomenclature

Name	Description
V_{AC}	Line Input Voltage
V_D	Drain Voltage
I_D	Drain Current
V_{CC}	VCC Pin Voltage
V_{FB}	Feedback Voltage
V_{LINE}	Line Pin Voltage
V_{O-12V}	12 V Output Voltage
V_{O-15V}	15 V Output voltage
$t_{startup}$	Time from when the AC switch is turned on until the output voltage reaches 90%
f_s	Operation Frequency
V_{FB-BUR}	Burst-mode Start Threshold Voltage
$V_{FB-BURH}$	Burst-mode End Threshold Voltage
$t_D-VNOFF$	Brown-out Debounce Time
N_{VINOV}	VIN OVP Debounce Counting Number
t_D-OLP	FB OLP Debounce Time
N_{CSSP}	CSSP Debounce Counting Number

Operation Contents

1. Startup Operation
2. Normal Operation
3. Output Ripple Voltage
4. Burst Mode In/Out
5. Load Transient
 - a. Load Change: 20% → 80%
 - b. Load Change: 80% → 20%
6. Protection
 - a. Brown Out
 - b. Line Over Voltage Protection (LOVP)
 - c. Vcc Over Voltage Protection (OVP)
 - d. Over Load Protection (OLP)
 - e. Current Sense Short Protection (CSSP)
 - Startup at sensing resistor short
 - Short sensing resistor during normal operation
 - f. Thermal Shutdown Protection (TSD)

NCP11187A65P45WGEVB

1. Start-up Operation

CH1: V_{AC} , 400 V/div, CH2: V_{FB} , 5 V/div, CH3: I_D , 1 A/div, CH4: V_{O-12V} , 5 V/div

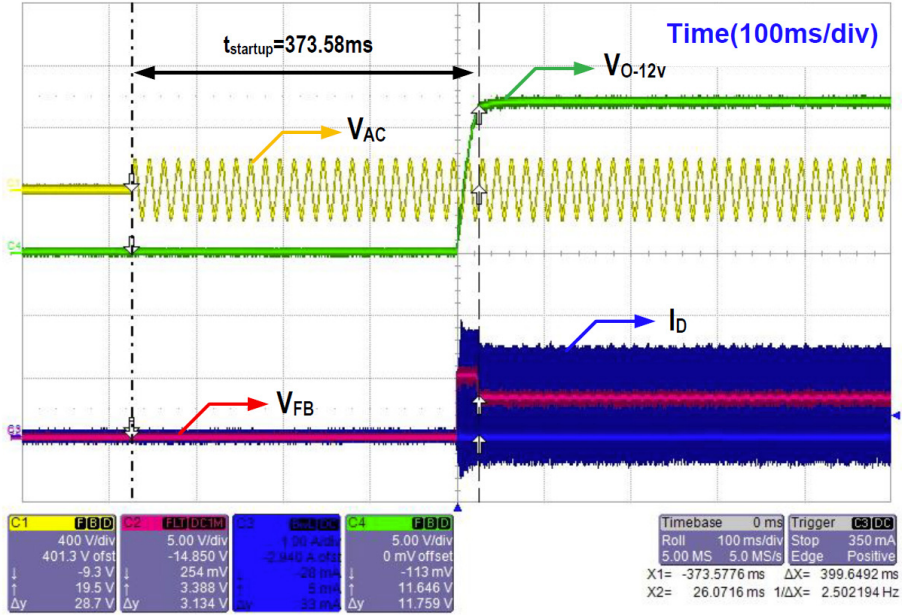

Figure 13. Start-up Operation @115 V_{AC} /60 Hz, Full Load

CH1: V_{AC} , 400 V/div, CH2: V_{FB} , 5 V/div, CH3: I_D , 1 A/div, CH4: V_{O-12V} , 5 V/div

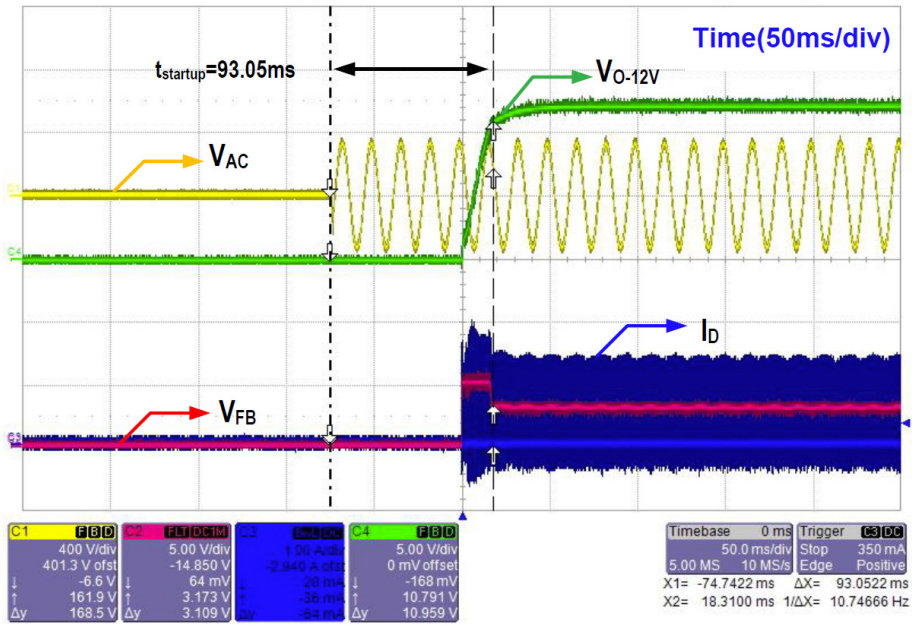

Figure 14. Start-up Operation @230 V_{AC} /60 Hz, Full Load

NCP11187A65P45WGEVB

2. Normal Operation

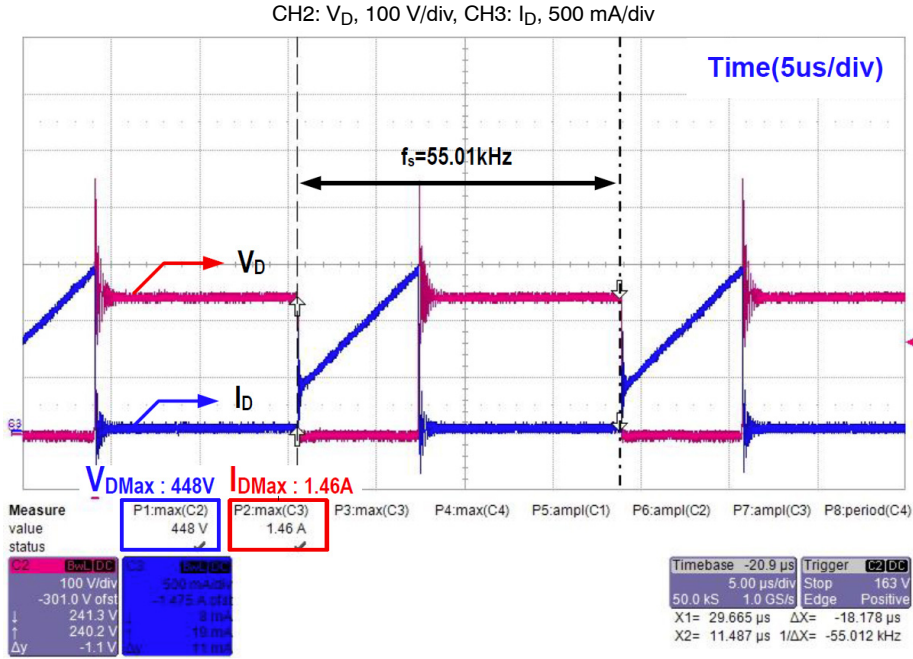

Figure 15. Normal Operation @ 115 V_{AC} /60 Hz, Full Load

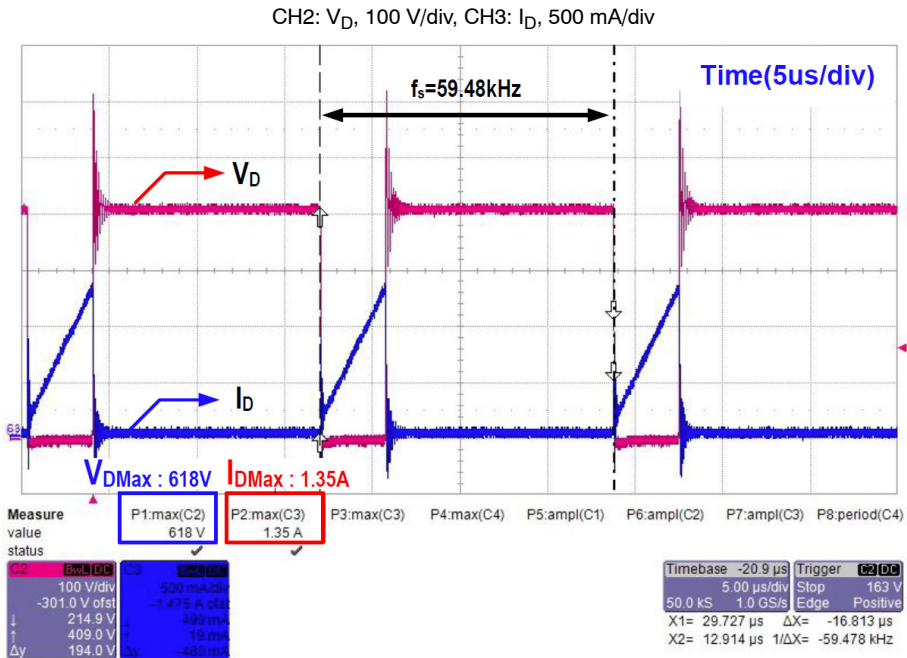

Figure 16. Normal Operation @ 230 V_{AC} /60 Hz, Full Load

NCP11187A65P45WGEVB

3. Output Ripple Voltage

- ◆ Test method

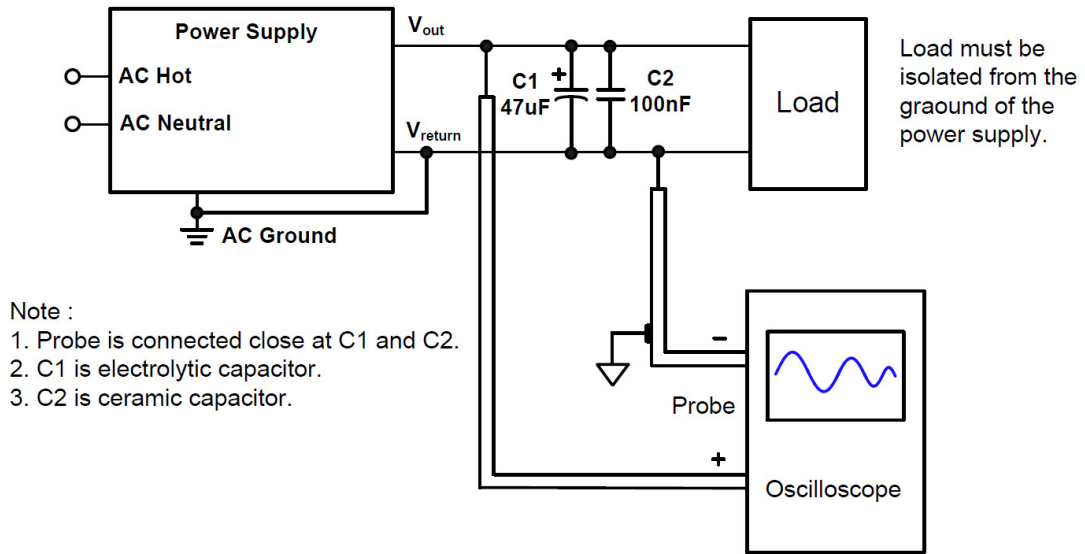

Figure 17. Test Method for Output Ripple and Noise

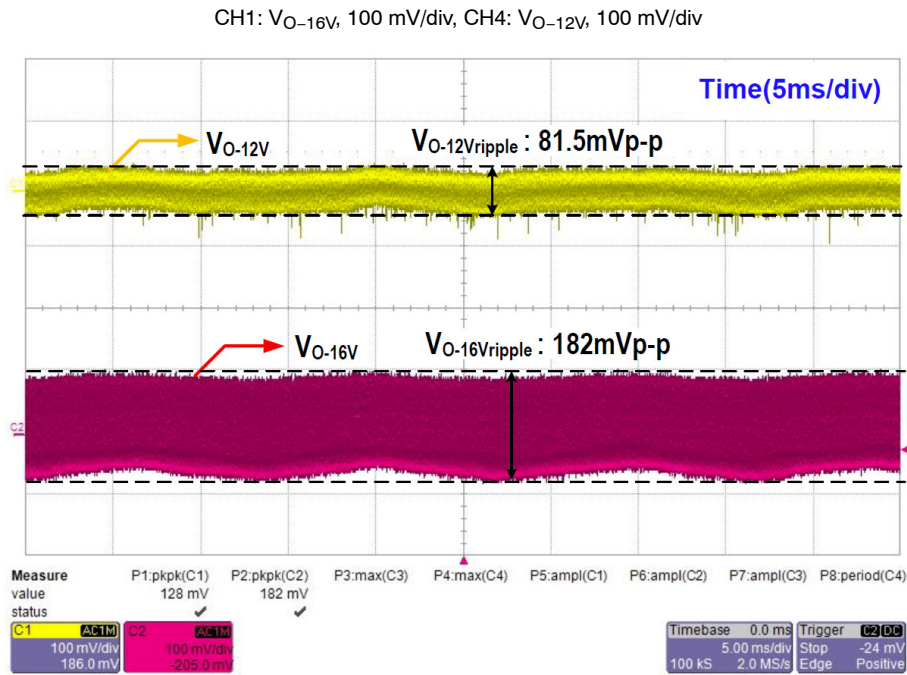

Figure 18. Output Ripple Voltage @115 V_{AC} /60 Hz, Full Load

NCP11187A65P45WGEVB

CH1: V_{O-16V} , 100 mV/div, CH4: V_{O-12V} , 100 mV/div

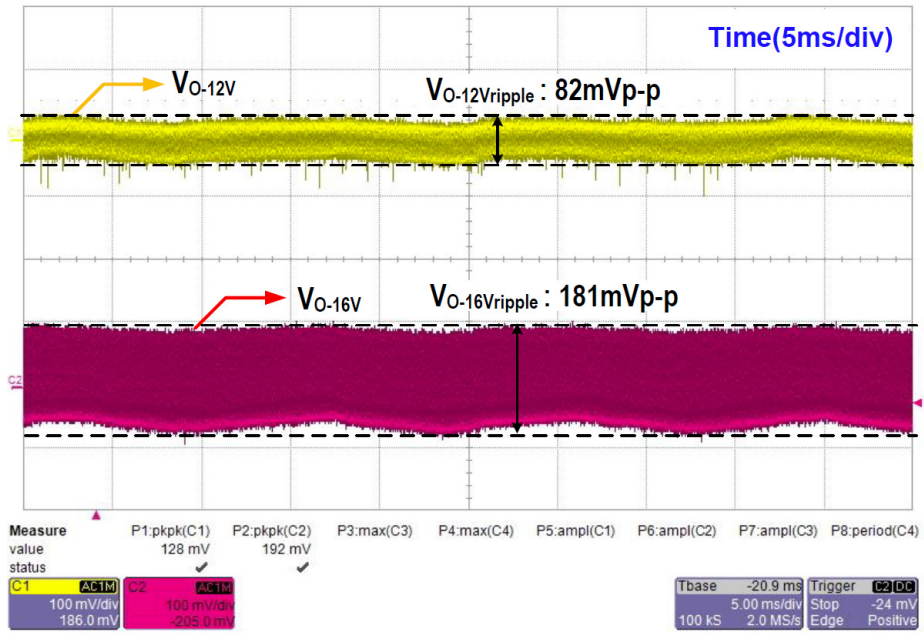

Figure 19. Output Ripple Voltage @230 V_{AC} /60 Hz, Full Load

NCP11187A65P45WGEVB

4. Burst Mode In/Out

CH2: V_{FB} , 500 mV/div, CH3: I_D , 500 mA/div

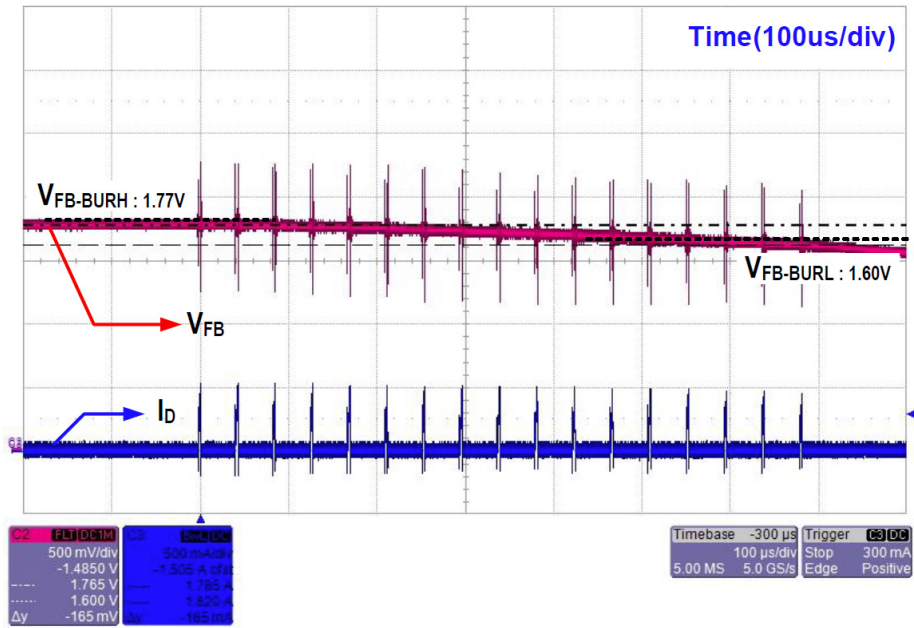

Figure 20. Burst Mode @115 V_{AC} /60 Hz, No Load

CH2: V_{FB} , 500 mV/div, CH3: I_D , 500 mA/div

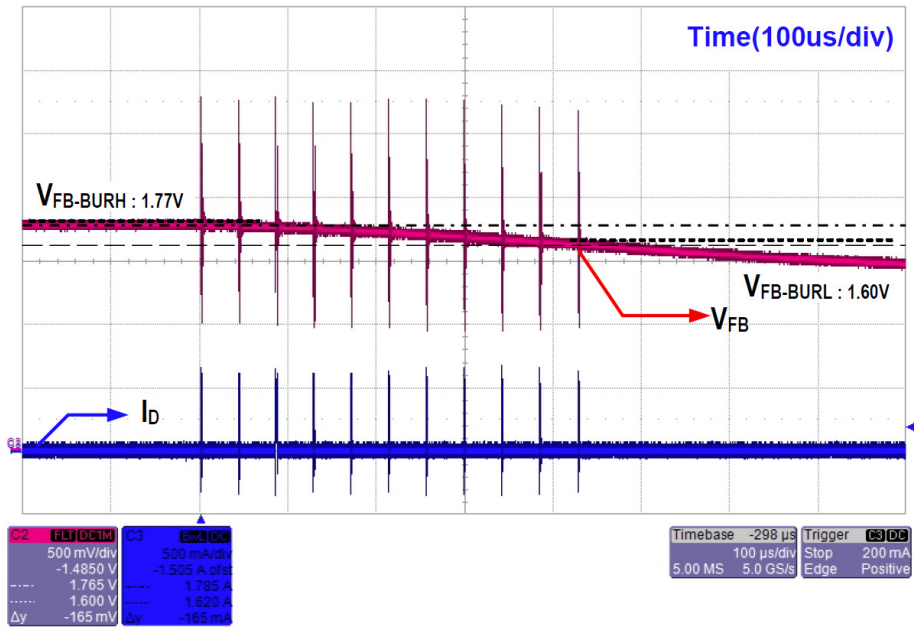

Figure 21. Burst Mode @230 V_{AC} /60 Hz, No Load

NCP11187A65P45WGEVB

5. Load Transient

a. Load Change: 20% → 80%

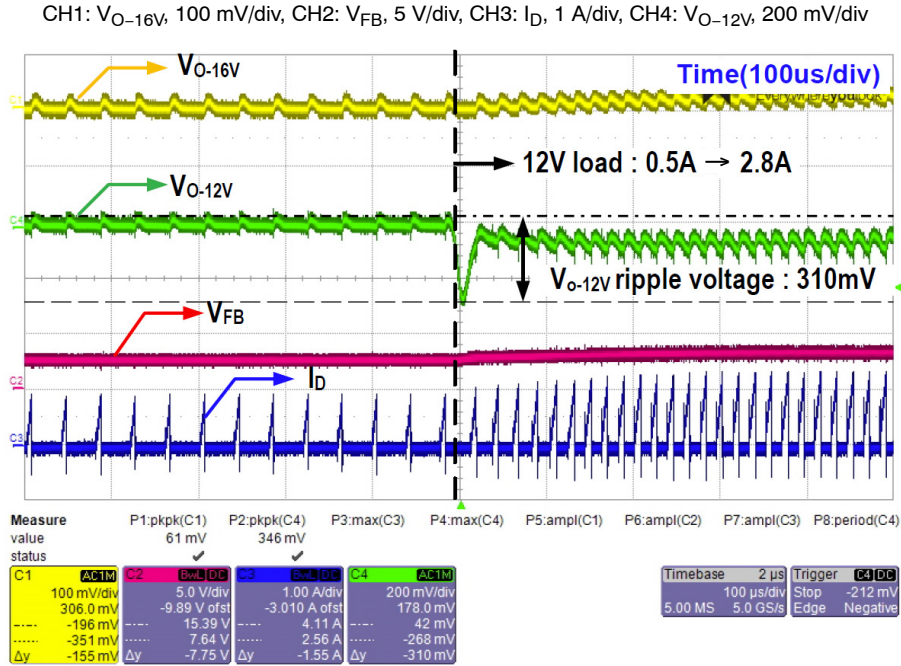

Figure 22. Load Transient @115 V_{AC} /60 Hz

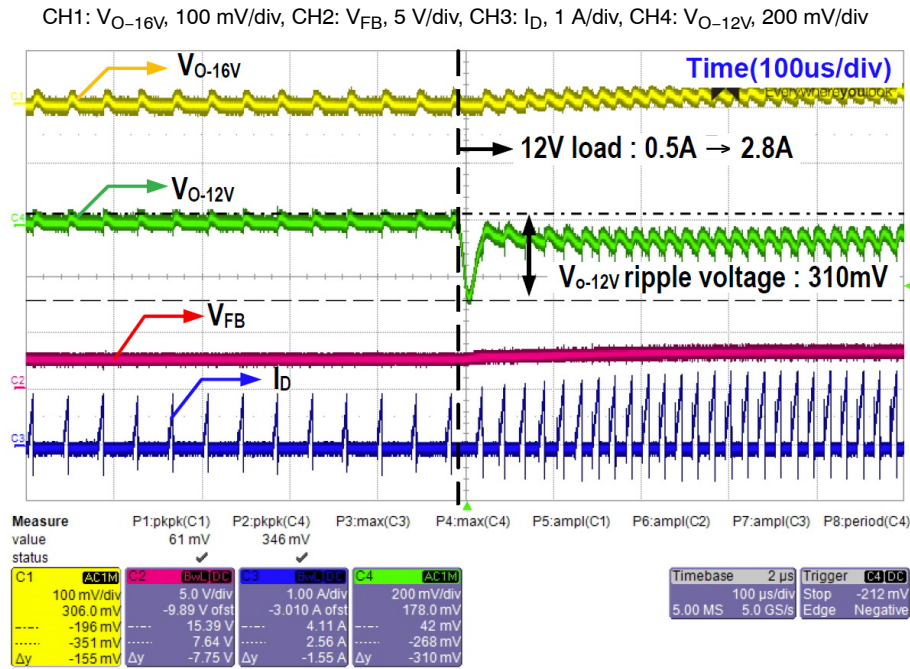

Figure 23. Load Transient @230 V_{AC} /60 Hz

NCP11187A65P45WGEVB

b. Load Change: 80% → 20%

CH1: V_{O-16V} , 100 mV/div, CH2: V_{FB} , 5 V/div, CH3: I_D , 1 A/div, CH4: V_{O-12V} , 200 mV/div

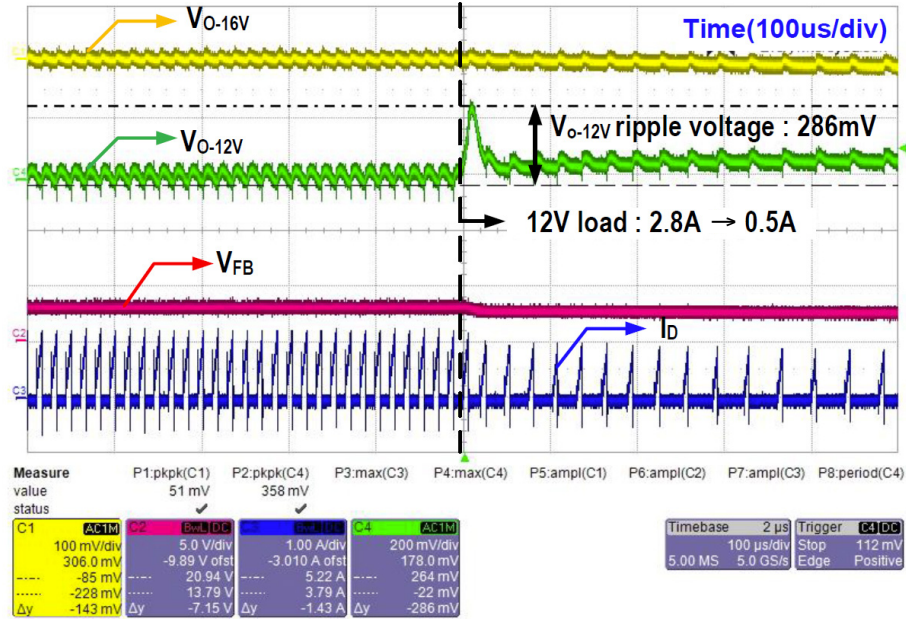

Figure 24. Load Transient @ 115 V_{AC} /60 Hz

CH1: V_{O-16V} , 100 mV/div, CH2: V_{FB} , 5 V/div, CH3: I_D , 1 A/div, CH4: V_{O-12V} , 200 mV/div

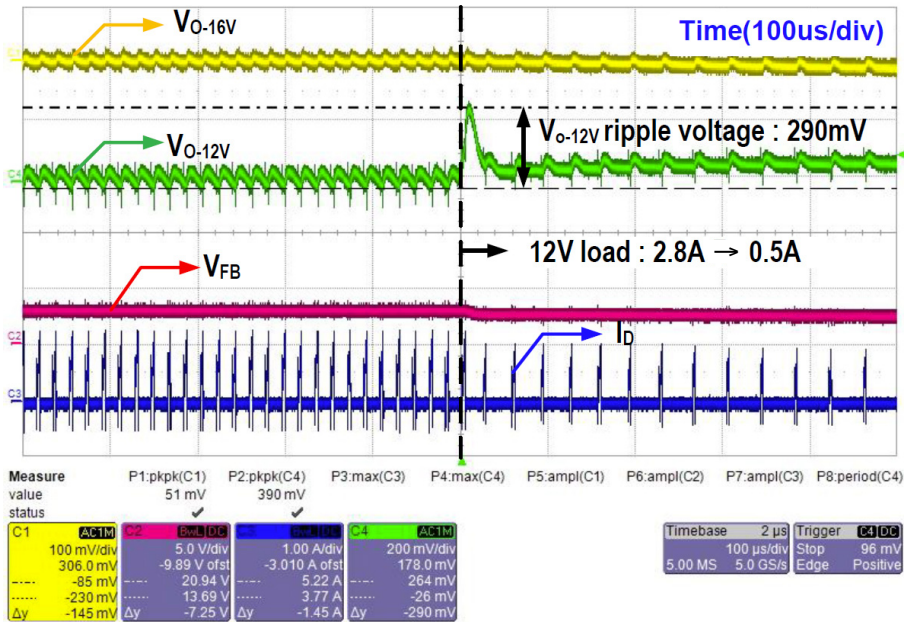

Figure 25. Load Transient @ 230 V_{AC} /60 Hz

NCP11187A65P45WGEVB

6. Protection a. Brown Out

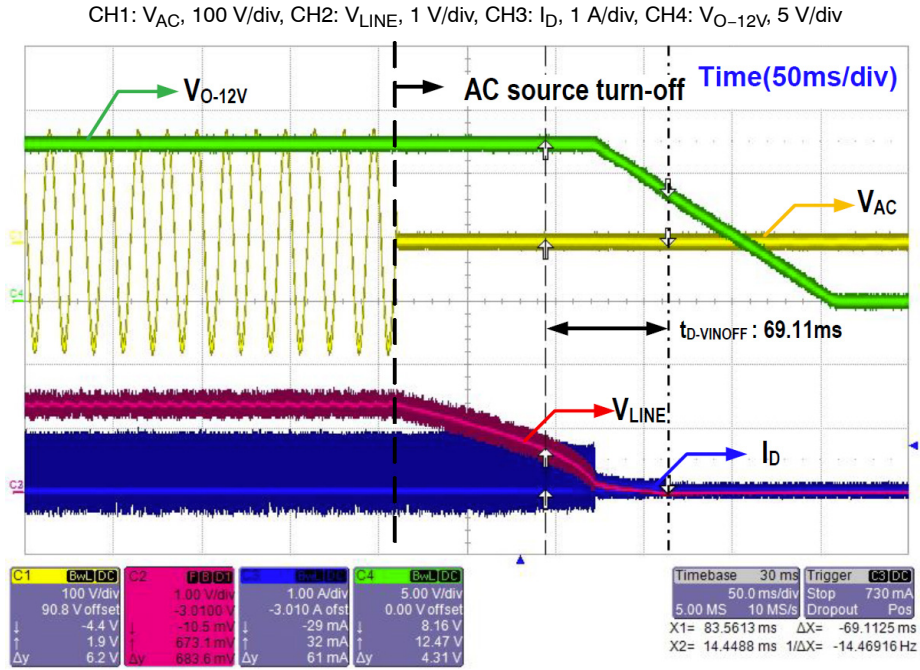

Figure 26. Brown Out @ Full Load

b. Line Over Voltage Protection (LOVP)

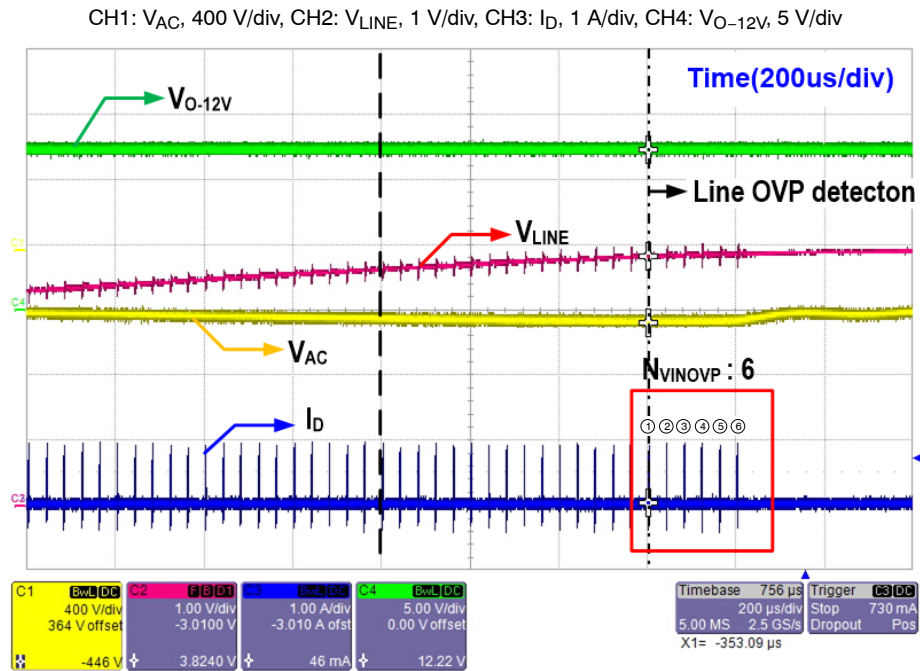

Figure 27. LOVP @ Full Load

NCP11187A65P45WGEVB

c. VCC Over Voltage Protection (OVP)

CH1: V_{CC} , 10 V/div, CH2: V_{FB} , 2 V/div, CH3: I_D , 1 A/div, CH4: V_{O-12V} , 5 V/div

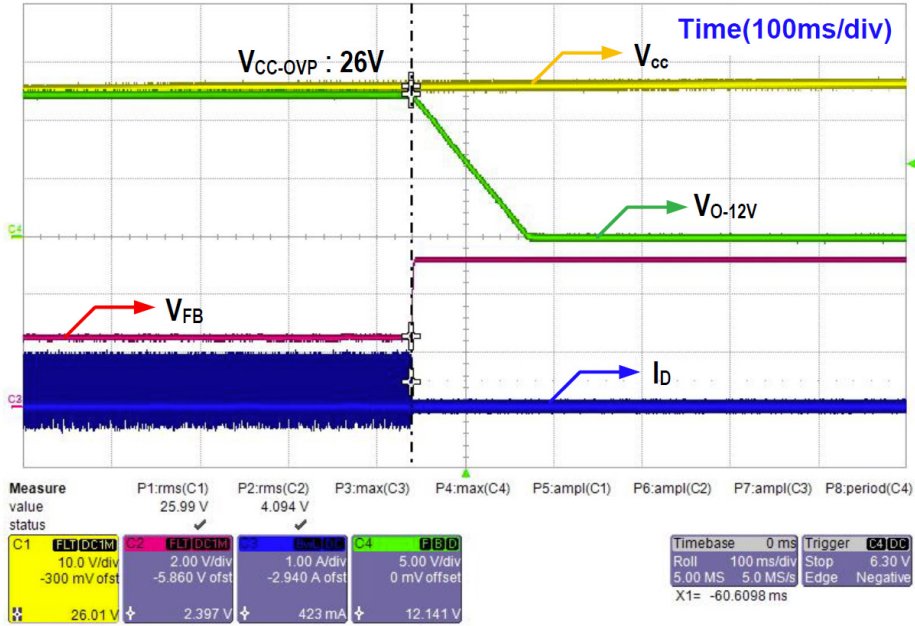

Figure 28. V_{CC} OVP @ 115 V_{AC} /60 Hz, Full Load

CH1: V_{CC} , 10 V/div, CH2: V_{FB} , 2 V/div, CH3: I_D , 1 A/div, CH4: V_{O-12V} , 5 V/div

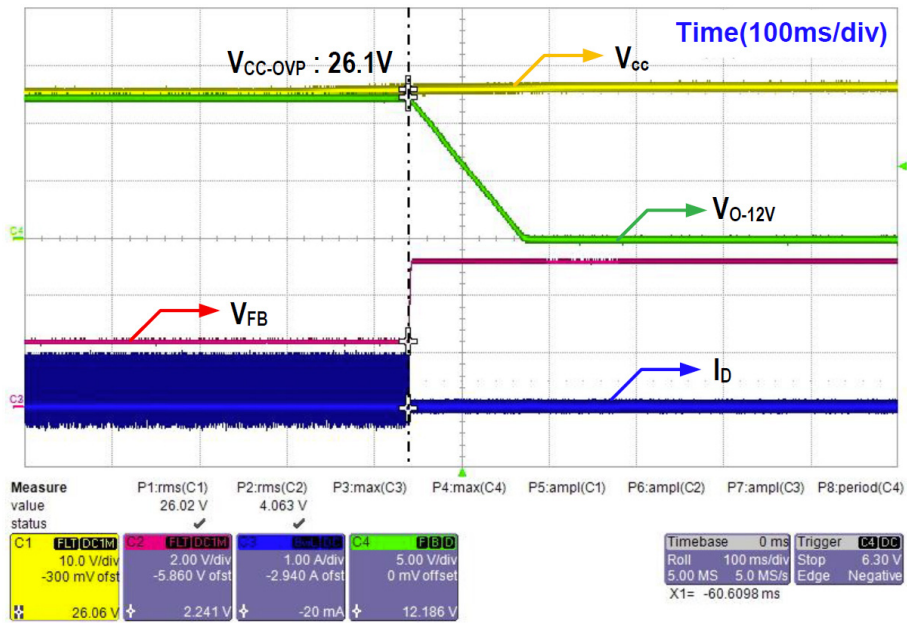

Figure 29. V_{CC} OVP @ 230 V_{AC} /60 Hz, Full Load

NCP11187A65P45WGEVB

d. Over Load Protection (OLP)

- Test method: Output short during operation
- ◆ t_{D_OLP} : FB OLP Debounce Time

CH1: V_{CC} , 10 V/div, CH2: V_{FB} , 2 V/div, CH3: I_D , 1 A/div, CH4: V_{O-12V} , 5 V/div

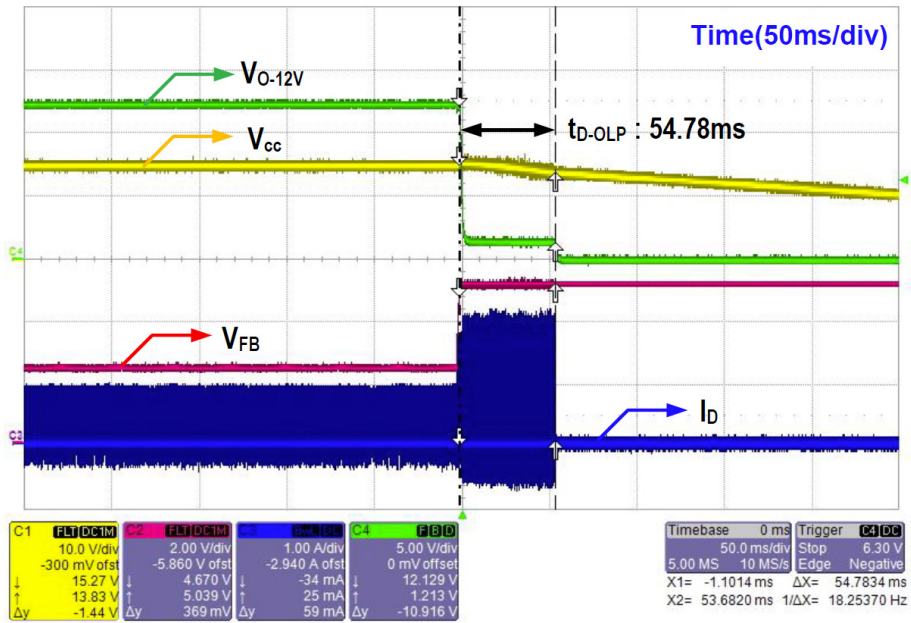

Figure 30. OLP @ 115 V_{AC} /60 Hz

CH1: V_{CC} , 10 V/div, CH2: V_{FB} , 2 V/div, CH3: I_D , 1 A/div, CH4: V_{O-12V} , 5 V/div

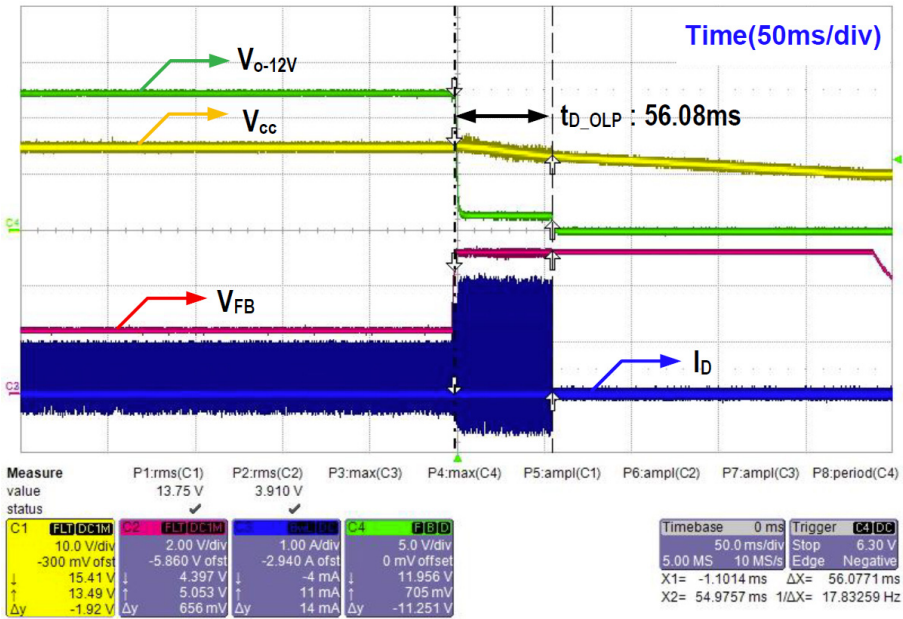

Figure 31. OLP @ 230 V_{AC} /60 Hz

NCP11187A65P45WGEVB

e. Current Sense Short Protection (CSSP)

- ◆ Startup at sensing resistor short

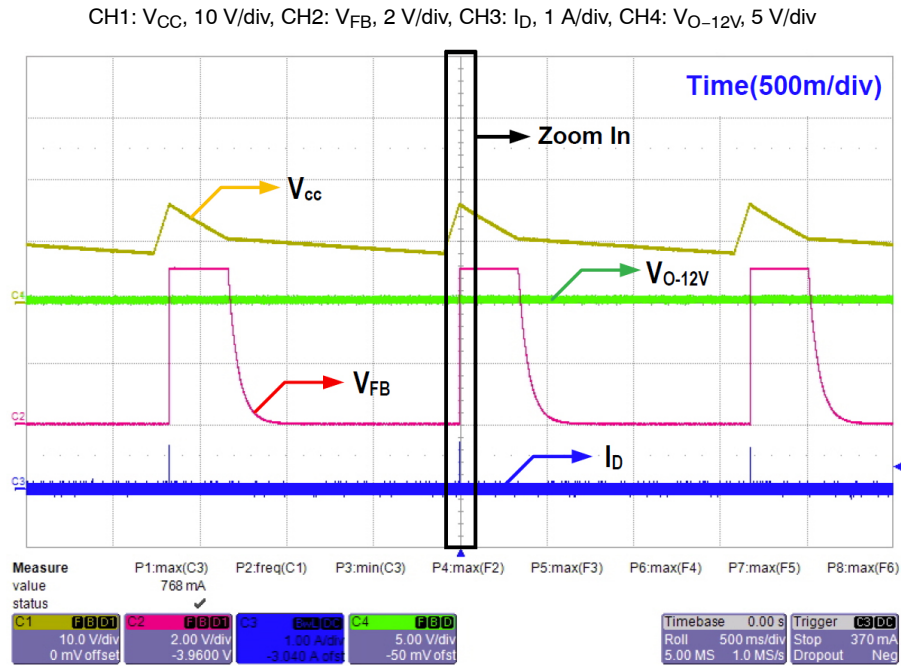

Figure 32. CSSP @ 115 V_{AC} /60 Hz, Full Load (Roll Mode)

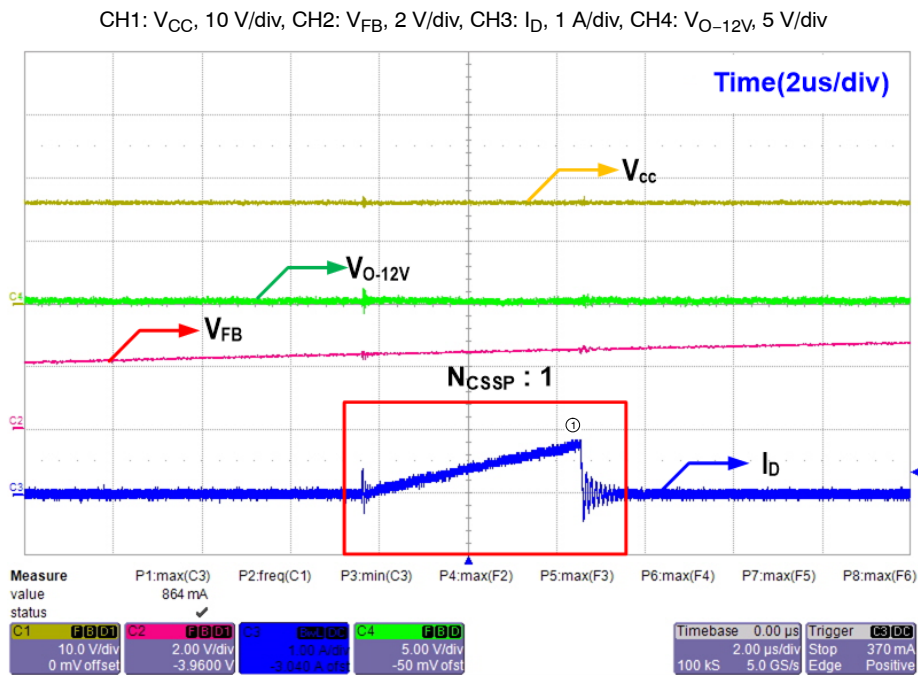

Figure 33. CSSP @ 115 V_{AC} /60 Hz, Full Load (Zoom In)

NCP11187A65P45WGEVB

CH1: V_{CC} , 10 V/div, CH2: V_{FB} , 2 V/div, CH3: I_D , 1 A/div, CH4: V_{O-12V} , 5 V/div

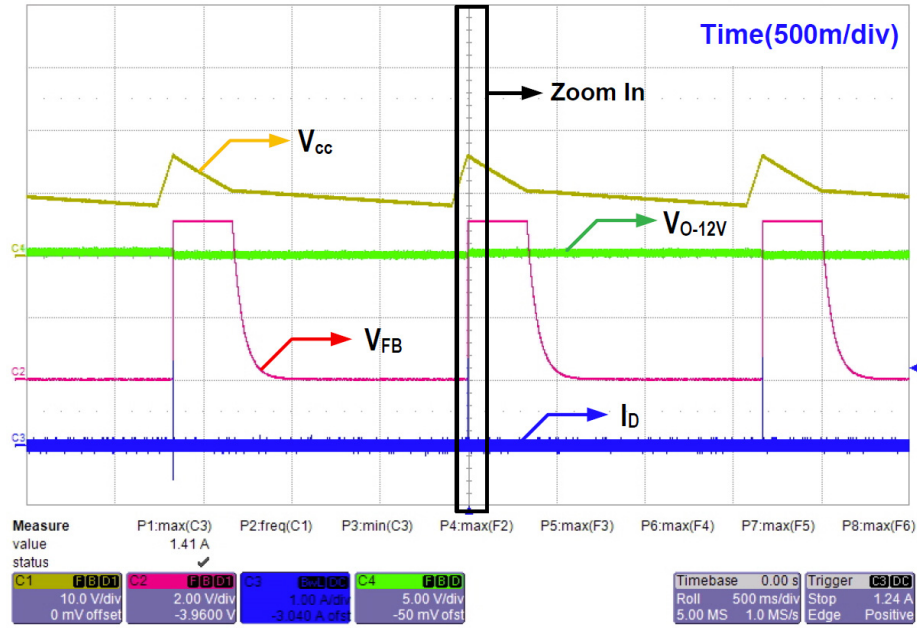

Figure 34. CSSP @ 230 V_{AC} /60 Hz, Full Load (Roll Mode)

CH1: V_{CC} , 10 V/div, CH2: V_{FB} , 2 V/div, CH3: I_D , 1 A/div, CH4: V_{O-12V} , 5 V/div

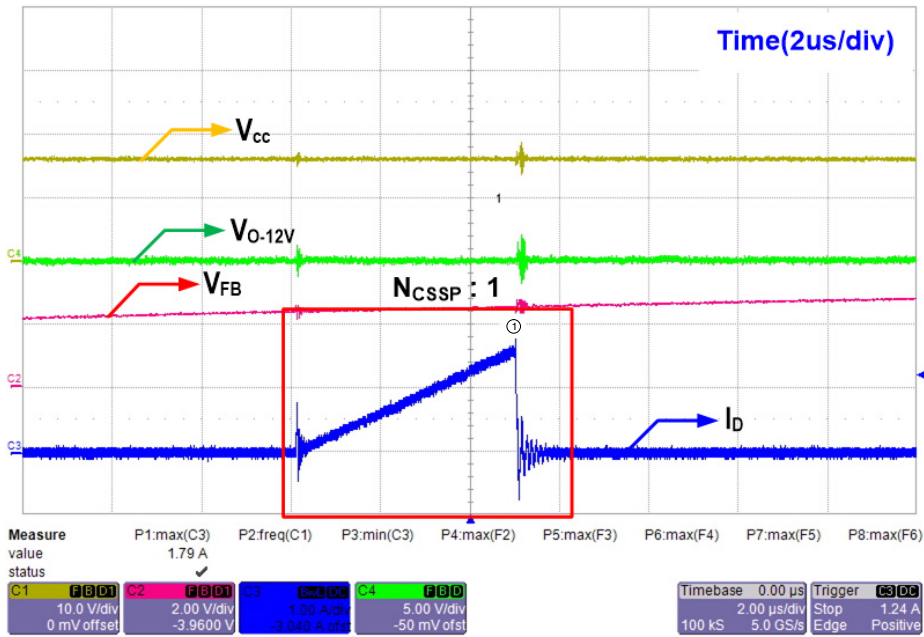

Figure 35. CSSP @ 230 V_{AC} /60 Hz, Full Load (Zoom In)

NCP11187A65P45WGEVB

- ◆ Short sensing resistor while operation

CH1: V_{CC} , 10 V/div, CH2: V_{FB} , 2 V/div, CH3: I_D , 1 A/div, CH4: V_{O-12V} , 5 V/div

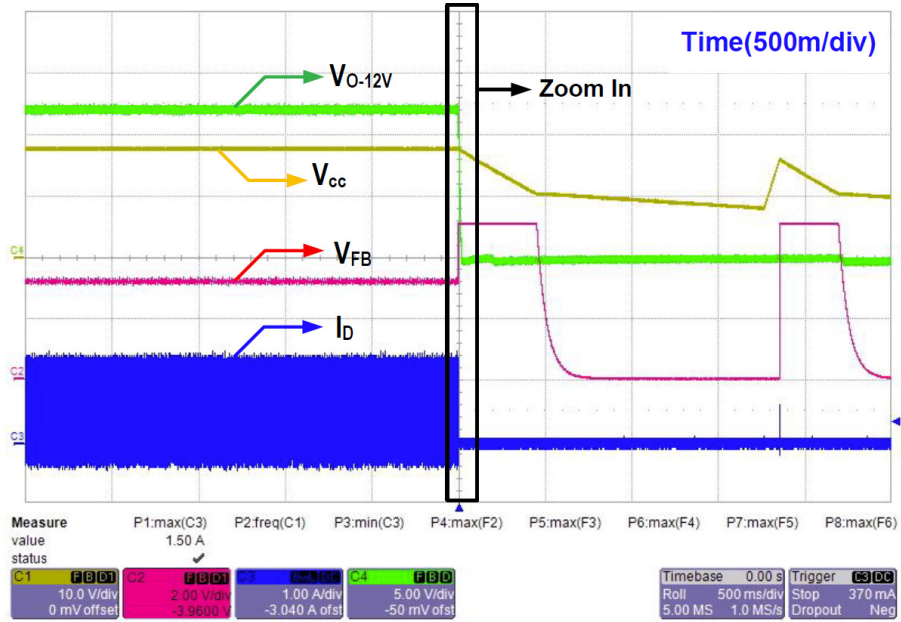

Figure 36. C_{SSP} @ 115 V_{AC}/60 Hz, Full Load (Roll Mode)

CH1: V_{CC} , 10 V/div, CH2: V_{FB} , 2 V/div, CH3: I_D , 1 A/div, CH4: V_{O-12V} , 5 V/div

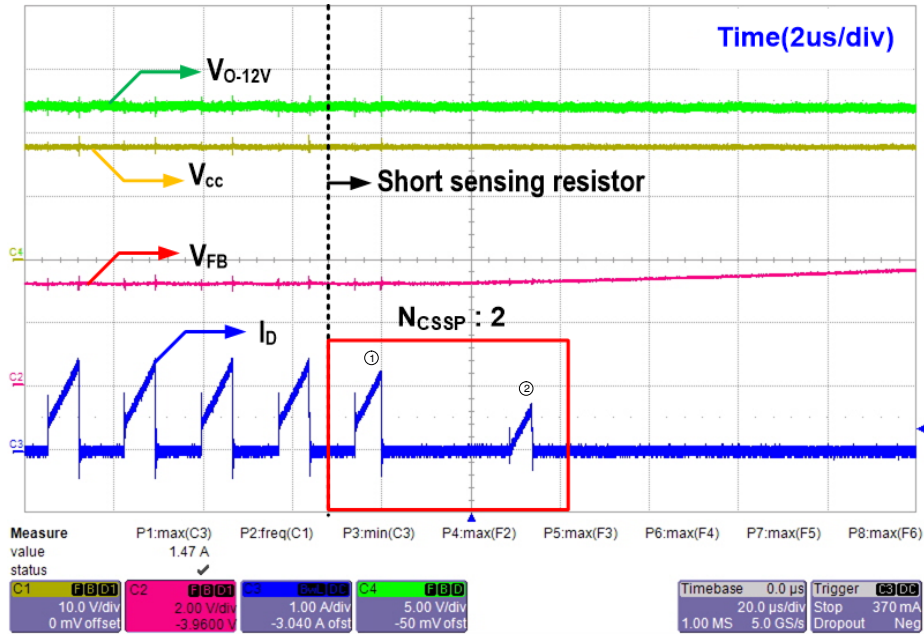

Figure 37. C_{SSP} @ 115 V_{AC}/60 Hz, Full Load (Zoom In)

NCP11187A65P45WGEVB

CH1: V_{CC} , 10 V/div, CH2: V_{FB} , 2 V/div, CH3: I_D , 1 A/div, CH4: V_{O-12V} , 5 V/div

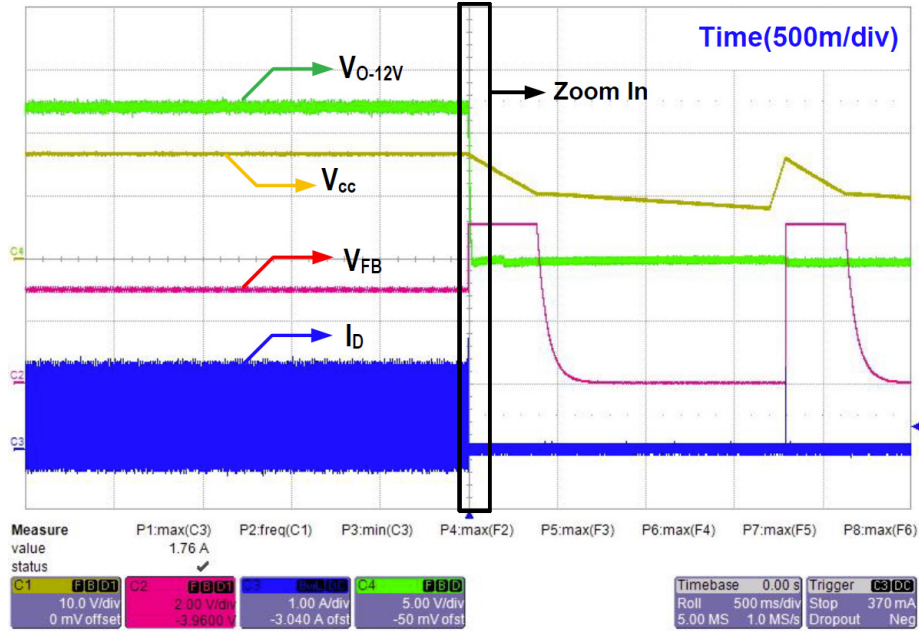

Figure 38. CSSP @ 230 V_{AC} /60 Hz, Full Load (Roll Mode)

CH1: V_{CC} , 10 V/div, CH2: V_{FB} , 2 V/div, CH3: I_D , 1 A/div, CH4: V_{O-12V} , 5 V/div

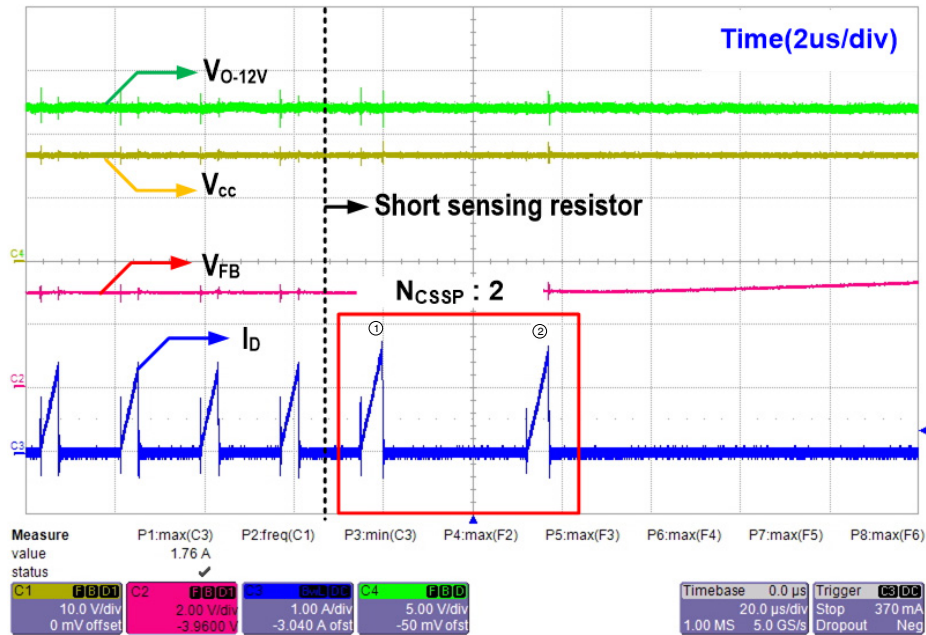

Figure 39. CSSP @ 230 V_{AC} /60 Hz, Full Load (Zoom In)

NCP11187A65P45WGEVB

7. Thermal Shutdown Protection (TSD)

CH1: V_{CC} , 10 V/div, CH2: V_{FB} , 2 V/div, CH3: I_D , 1 A/div, CH4: V_{O-12V} , 5 V/div

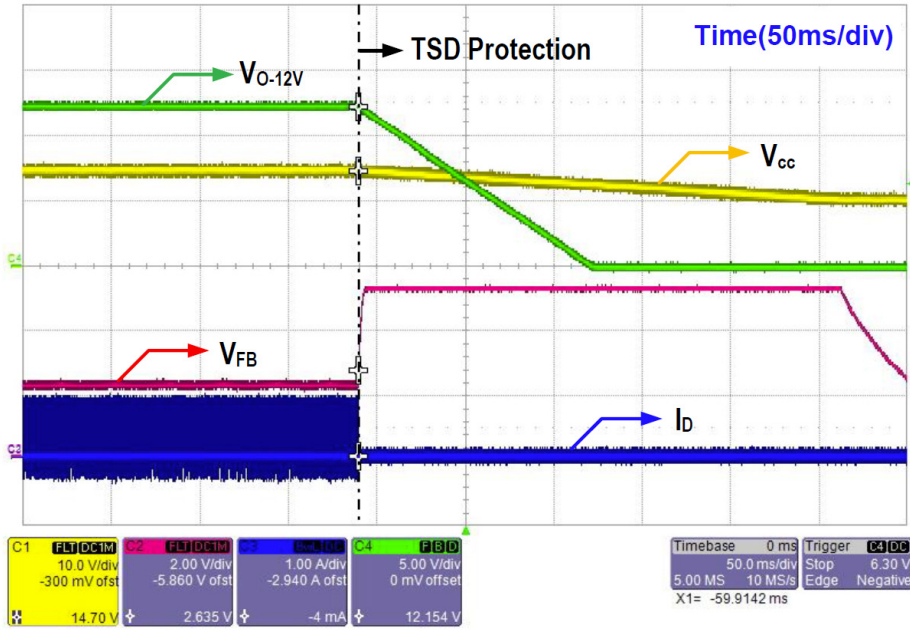

Figure 40. TSD @ 115 V_{AC} /60 Hz, Full Load

CH1: V_{CC} , 10 V/div, CH2: V_{FB} , 2 V/div, CH3: I_D , 1 A/div, CH4: V_{O-12V} , 5 V/div

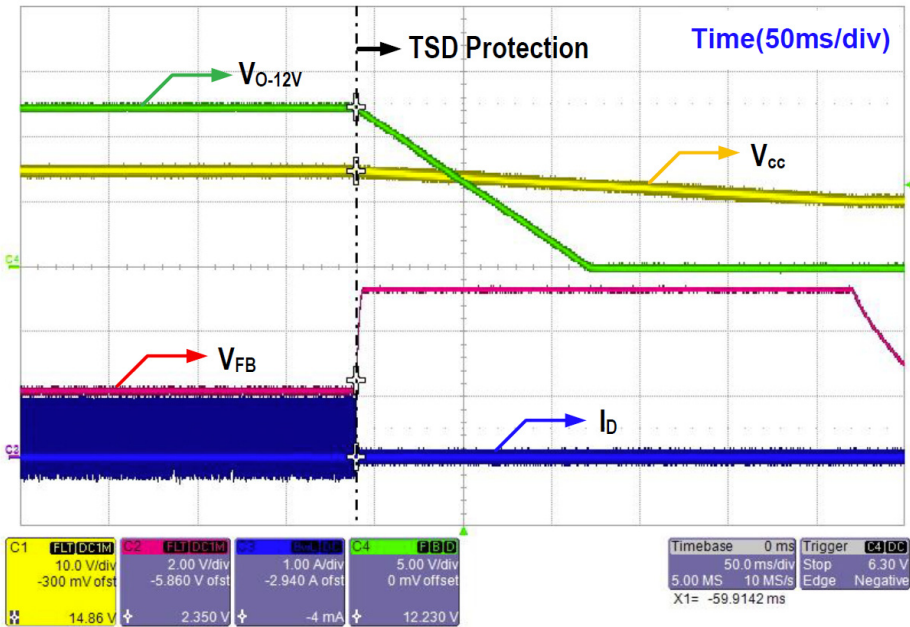

Figure 41. TSD @ 230 V_{AC} /60 Hz, Full Load

NCP11187A65P45WGEVB

BILL OF MATERIALS

Table 1. BILL OF MATERIALS

Parts	Qty	Description	Value	Tolerance	Footprint	Manufacturer	Part Number
C101	1	Electrolytic Capacitor	100 μ F/450 V		18 \times 31 mm	SAMYOUNG	NFA
C103	1	MLCC X7R capacitor	1 nF/10 V	\pm 5%	0805	Murata	
C104	1	MLCC X7R capacitor	100 nF/50 V	\pm 5%	0805	Murata	
C105, C204, C207	3	Electrolytic Capacitor	47 μ F/35 V		5 \times 11 mm	SAMYOUNG	NXH
C106	1	MLCC X7R capacitor	2 nF/10 V	\pm 5%	0603	Murata	
C201	1	MLCC X7R capacitor	100 pF/200 V	\pm 5%	1206	Yageo	
C202, C203	2	Electrolytic Capacitor	2200 μ F/16 V		12.5 \times 20 mm	SAMYOUNG	NXH
C205	1	MLCC X7R capacitor	470 pF/200 V	\pm 5%	1206	Yageo	
C206	1	Electrolytic Capacitor	680 μ F/25 V		10 \times 16 mm	SAMYOUNG	NXB
C208	1	MLCC X7R capacitor	27 nF/25 V	\pm 5%	0805	Murata	
CX101	1	X2 Capacitor	0.68 μ F/275 V	\pm 10%	11 \times 18.5 \times 18 mm	PILKOR	PCX2 337
CX102	1	X2 Capacitor	0.15 μ F/275 V	\pm 10%	6 \times 12 \times 80 mm	PILKOR	PCX2 337
CY101	1	Y1 Capacitor	4700 pF/250 V	\pm 20%	CY4.5X13	Murata	DE6E3KJ472MB3B
R101, R102, R112	3	Resistor SMD	10 M Ω	\pm 1%	1206	Rohm	
R103	1	Resistor SMD	270 k Ω	\pm 1%	0603	Rohm	
R106, R107, R108	3	Resistor SMD	2.7 Ω	\pm 1%	1206	Rohm	
R109, R110	2	Resistor SMD	2.2 Ω	\pm 1%	1206	Rohm	
R111	1	Resistor SMD	0 Ω	\pm 1%	0805	Rohm	
R201, R202	2	Resistor SMD	130 Ω	\pm 1%	1206	Rohm	
R203, R104	2	Resistor SMD	82 Ω	\pm 1%	1206	Rohm	
R205	1	Resistor SMD	750 Ω	\pm 1%	1206	Rohm	
R206	1	Resistor SMD	1.2 k Ω	\pm 1%	0805	Rohm	
R207	1	Resistor SMD	56 k Ω	\pm 1%	0805	Rohm	
R208	1	Resistor SMD	160 k Ω	\pm 1%	0805	Rohm	
R209	1	Resistor SMD	1.2 M Ω	\pm 1%	0805	Rohm	
R210	1	Resistor SMD	680 k Ω	\pm 1%	0805	Rohm	
R211	1	Resistor SMD	36 k Ω	\pm 1%	0805	Rohm	

NCP11187A65P45WGEVB

Table 1. BILL OF MATERIALS (continued)

Parts	Qty	Description	Value	Tolerance	Footprint	Manufacturer	Part Number
R212	1	Resistor SMD	1.8 k Ω	$\pm 1\%$	0805	Rohm	
D101, D102	2	Super Fast Rectifier	1000 V, 1 A		SMB	ON Semiconductor	MURS160T3G
D201	1	Schottky Rectifier	200 V, 20 A		TO-220	ON Semiconductor	MBR20200CT
D202	1	Schottky Rectifier	150 V, 10 A		TO-277	ON Semiconductor	FSV10150V
ZD101	1	TVS	220 V, 600 W		DO-15	ON Semiconductor	P6KE220A
BD101	1	Bridge Rectifier	600 V, 6 A		GBU 6J	ON Semiconductor	GBU6J
LF101	1	CM Choke	40 mH/1.3 A		21 \times 10 mm	TNC	CV613400SH
L201	1	Radial Lead Inductor	1.5 μ H/5.4 A	$\pm 20\%$	8.7 \times 10 mm, 5 mm pitch	BOURNS	RLB0912-1R5ML
L202	1	Radial Lead Inductor	1.5 μ H/0.92 A	$\pm 20\%$	5 \times 6.5 mm, 2 mm pitch	BOURNS	RLB0608-1R5ML
T201	1	Transformer	940 μ H	$\pm 10\%$	PQ2625, 12Pin	TDK	PQ2625
F101	1	Radial Lead Fuse	250 Vac, 2 A		SS-5	Little fuse	392 1200 0000
U101	1	PWM switcher	NCP11187		7DIP	ON Semiconductor	NCP11187A65F
U201	1	Opto coupler	CTR = 100%		DIP 4-pin	ON Semiconductor	FOD817A
U202	1	Shunt Regulator	Adjustable, 2.5 V	1%	SOT-23F 3L	ON Semiconductor	NCP431BCSNT1G
CN101	1	Connector	3Pin		pitch 3.96 mm	MOLEX	5273-03A
CN201	1	Connector	4Pin		pitch 3.96 mm	MOLEX	5273-04A
JP1	1	Jumper wire	Short		13.5 mm		
PCB	1	PCB					

All brand names and product names appearing in this document are registered trademarks or trademarks of their respective holders.