



Test Procedure for the NCP1380DGEVB Evaluation Board

I - Test Setup

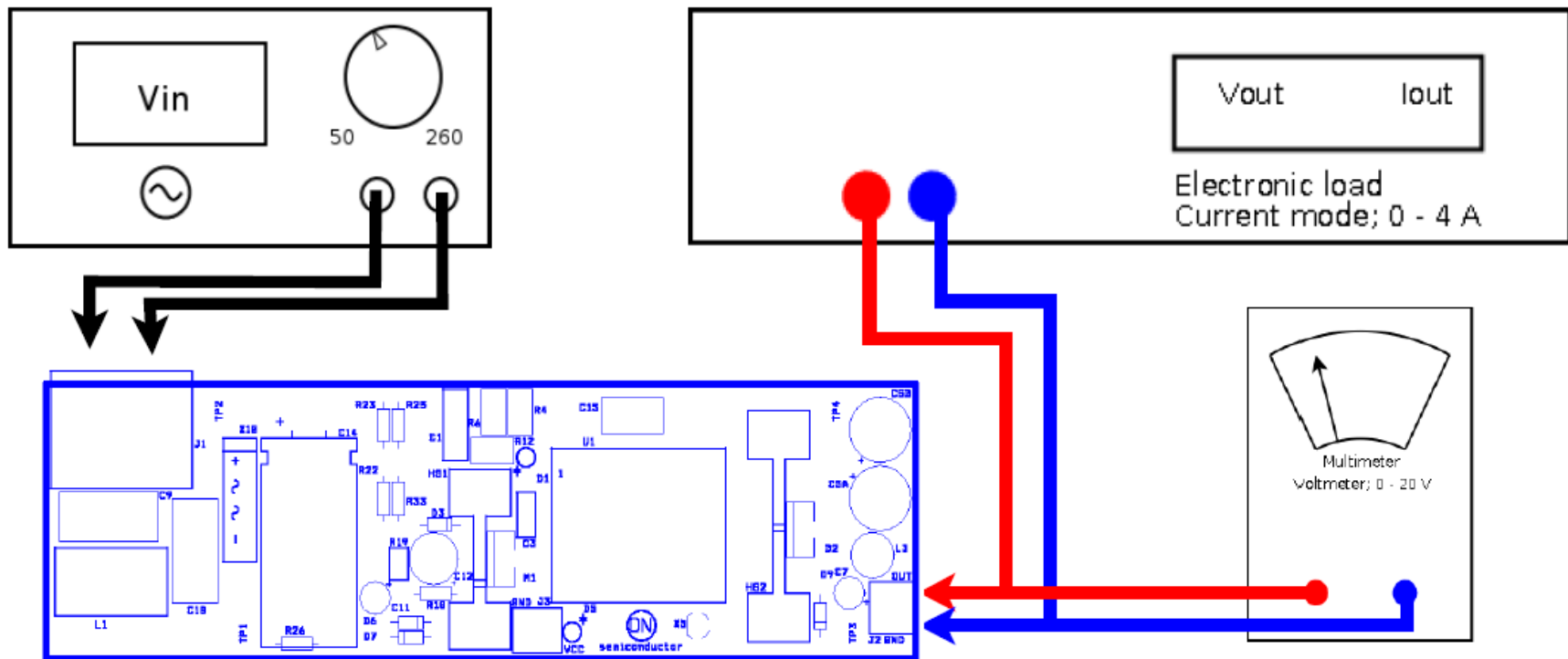

Figure 1: Test Setup



Required equipment:

- Ac power supply: 85 – 265 Vrms, 2 A
- Yokogawa power meter WT210
- Voltmeter
- Electronic load: 19 V, up to 4 A

II – Test Procedure

1. Make sure the S11 point is shorted as shown in Figure 2.

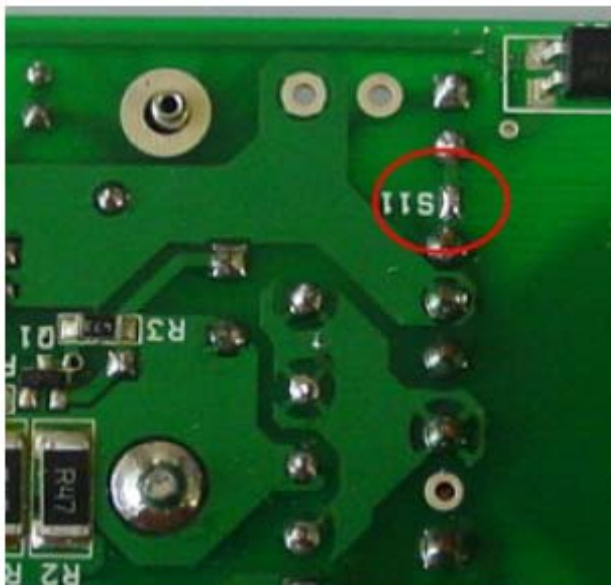

Figure 2: aux. winding connection

2. Connect the equipments to the board as shown in Figure 1.