

NCP4306 Synchronous Rectification Evaluation Board User's Manual



ON Semiconductor®

www.onsemi.com

Description

This evaluation board user's manual describes a high efficiency synchronous rectification evaluation board that can easily replace a secondary side rectification diode in an SMPS.

The NCP4306 is used as synchronous rectification controller. The evaluation board has very few external components and illustrates how small and effective such a design can be.

The NCP4306 features a very precise 0 mV turn-off comparator that supports even very low current flowing through the MOSFET even when very low $R_{DS(on)}$ synchronous MOSFETs is used. NCP4306 can be used in application working in DCM and CCM without any additional circuits thanks to very low propagation delays and strong driver output.

Key Features

- Precise Turn-off Comparator
- Wide Input Voltage Range
- High Operation Frequency
- Strong MOSFET Driver
- High Efficiency
- Adjustable Minimum On and Off Times
- Adjustable Light Load Detection Feature
- Small Size

Table 1.

SMPS Type	Supply Voltage	Reverse Voltage	Effective Resistance
Flyback, QR	4 – 35 V	100 V	3.3 mΩ

EVAl BOARD USER'S MANUAL

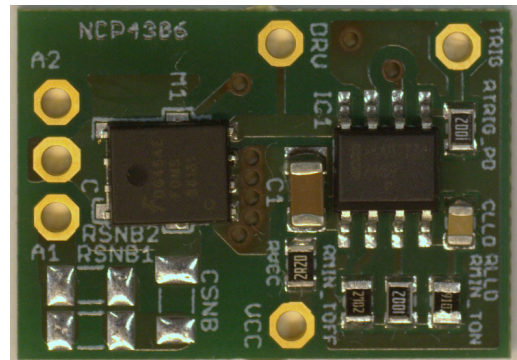

Figure 1. Evaluation Board Photo

CONNECTION DIAGRAM

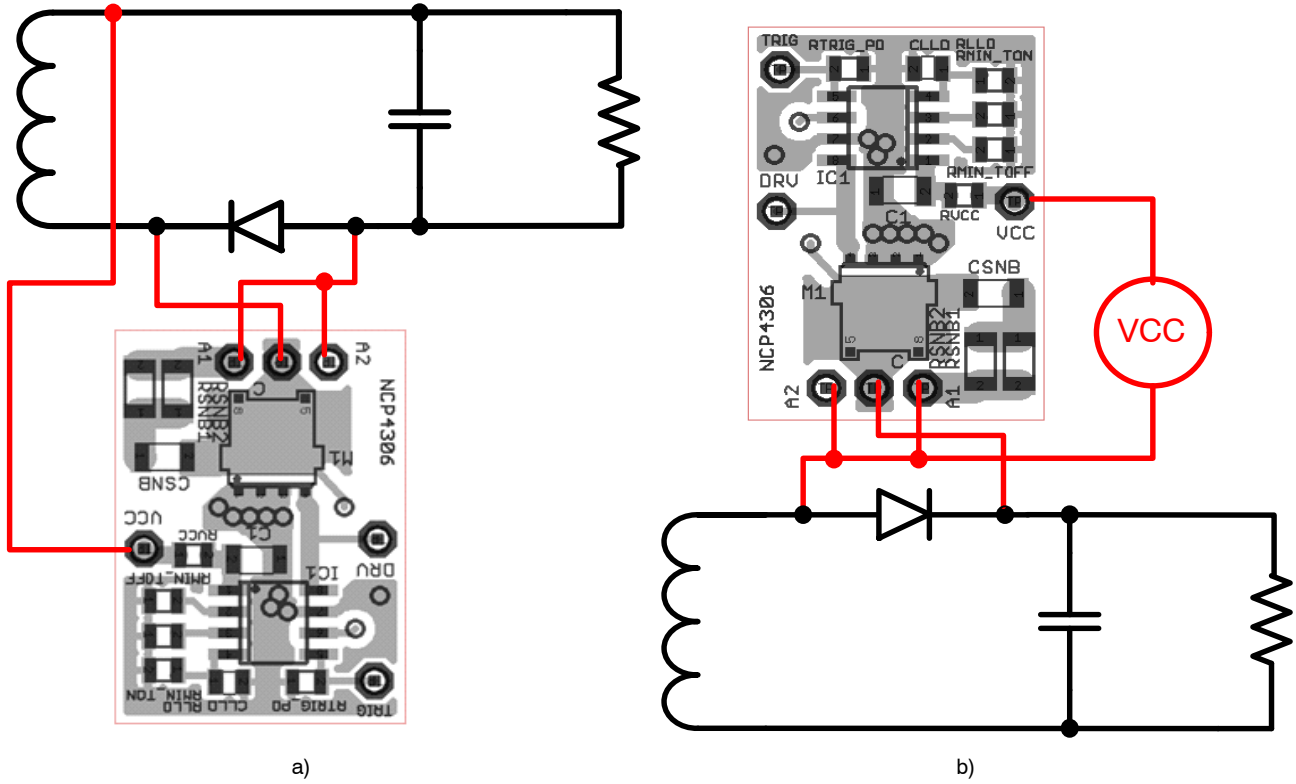

Figure 2. Possible Connections into Circuit

The evaluation board can be connected in circuit where the rectification diode is in the positive (Figure 2b) or negative (Figure 2a) branch. Connection to negative branch is simpler, VCC can be taken from SMPS VOUT if VOUT is in range of NCP4306 supply requirements. If connection

to a positive branch is used, it is necessary to use an external power supply, auxiliary winding with rectification or regulator supplied from transformer forward voltage (Figure 3) to provide power to the evaluation board. VCC should be referenced to A1 or A2 points.

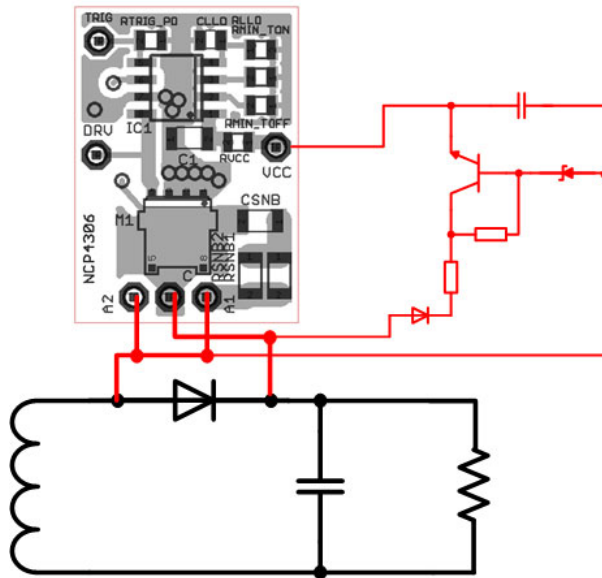

Figure 3. External Voltage Regulator for SR Supply

EVALUATION BOARD SCHEMATIC

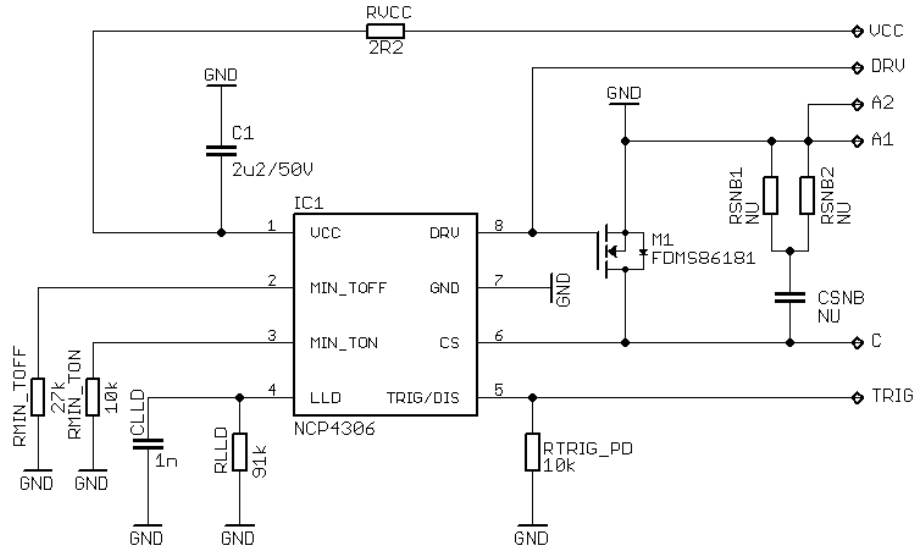

Figure 4. Schematic of the NCP4306

The evaluation board was designed to support a minimal external component count implementation. C1 is decoupling capacitor that should be placed as close as possible to the VCC and GND pins. Resistors RMIN_TON and RMIN_TOFF are used to set the protection interval when the synchronous MOSFET is turned on and off. It may be needed to adjust them according to used SMPS. RLLD

sets light load detection time and CLLD is optional for LLD voltage decoupling. Components CSNB, RSNB1 and RSNB2 form a snubber circuit.

Transistor M1 is 100 V V_{DS} capable, $R_{DS(on)}$ of 3.3 m Ω typ@10 V with soft recovery body diode that allows to omit snubber circuit without ringing and overshoots at SR transistor drain.

CIRCUIT LAYOUT

The PCB consists of a 2 layer FR4 board with 35 μm copper cladding. All components are surface mount and use 0805 and 1206 size for easy rework. Critical component such as blocking capacitor C1 has to be placed carefully near the IC. The synchronous driver path to the MOSFETs was done with very low resistance and parasitic inductance to

minimize emissions and minimize turn-on and turn-off times. The same is true for the CS pin. For the CS pin, a kelvin contact was done to be able to sense the voltage directly at the drain. Improper connection of the GND and CS connects can impact the turn-off process especially when a very low $R_{\text{DS(on)}}$ MOSFETs are used.

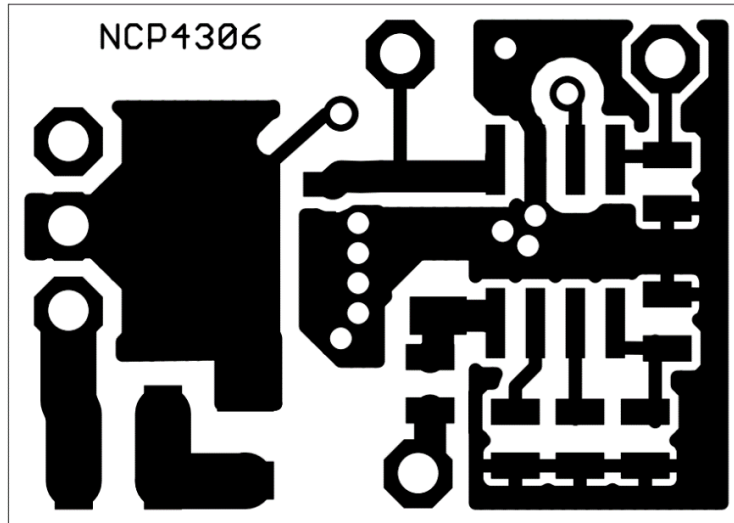

Figure 5. Top Layer

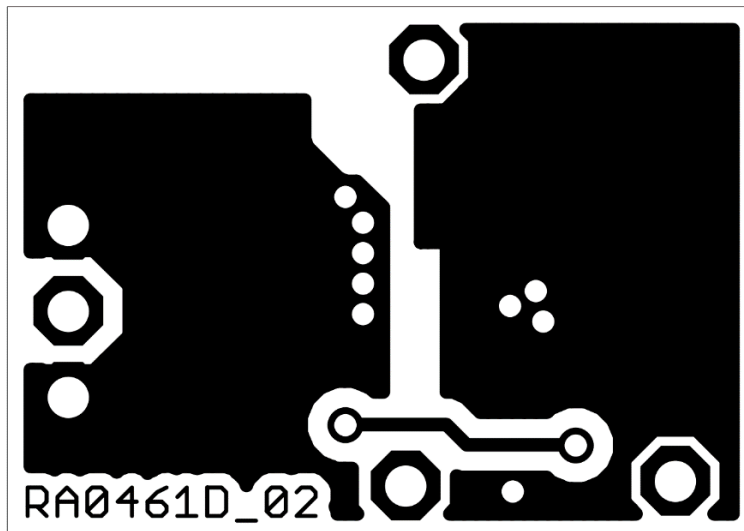

Figure 6. Bottom Layer

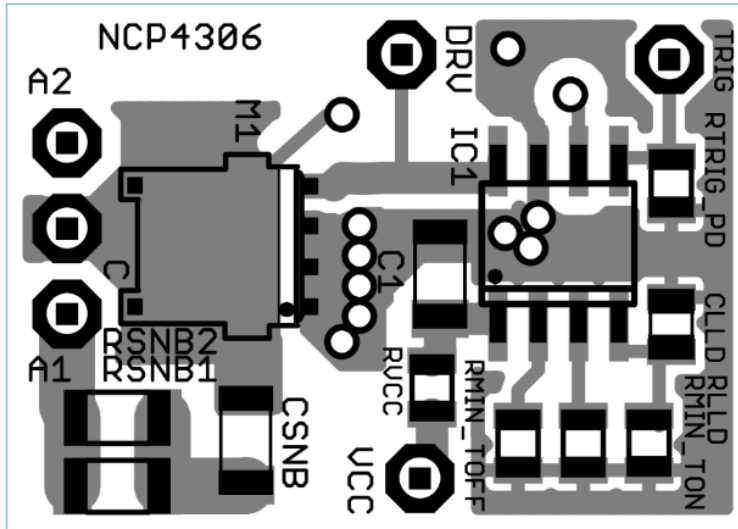

Figure 7. Top Side Components

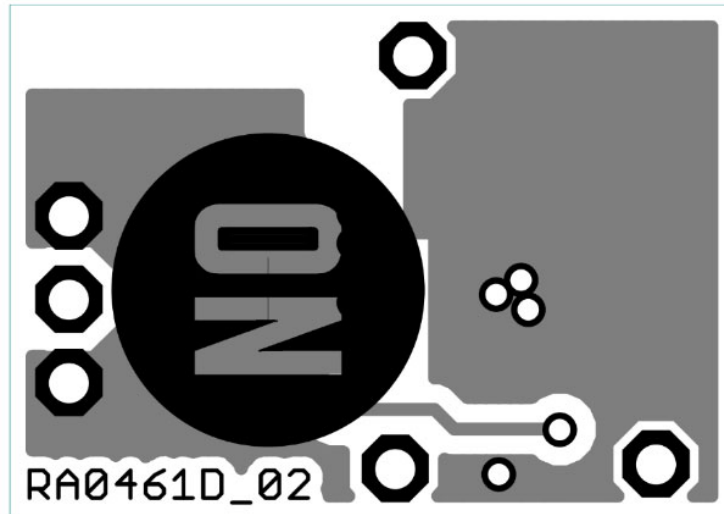

Figure 8. Bottom Side Components

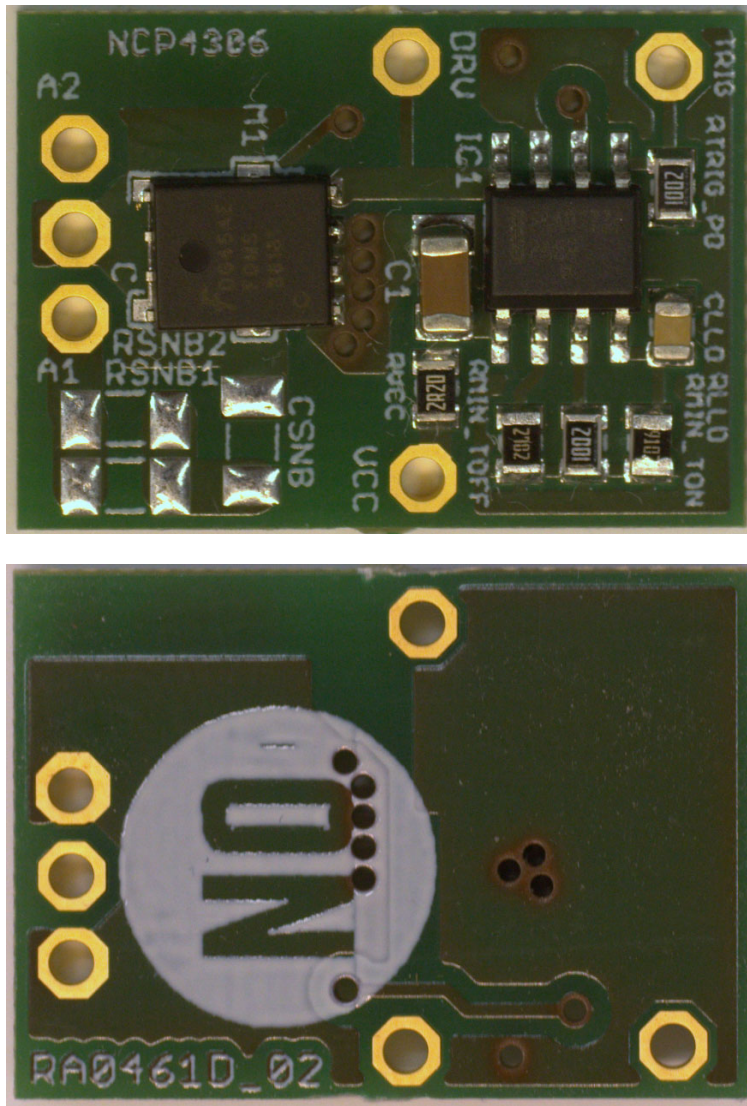

Figure 9. Evaluation Board Photos

EVBUM2522/D

BILL OF MATERIAL

Table 2. BILL OF MATERIAL FOR THE NCP4306 PUT-IN BOARD SO8FL 100 V

Designator	Qty	Description	Value	Tolerance	Footprint	Manufacturer	Manufacturer Part Number	Substitution Allowed
C1	1	Ceramic Capacitor	2.2 μ F / 50 V	10%	1206	KEMET	C1206C225K5RACTU	Yes
CLLD	1	Ceramic Capacitor	1 nF	20%	0805	KEMET	C0805C102M5RACTU	Yes
CSNB	1	Ceramic Capacitor	NU	-	1206	-	-	Yes
IC1	1	Secondary Side Synchronous Rectification Controller	NCP4306AADZZA	-	SOIC-08	ON Semiconductor	NCP4306AADZZAD R2G	No
M1	1	N-Channel Power MOSFET	FDMS86181	-	Power 56	ON Semiconductor	FDMS86181	Yes
RVCC	1	Resistor SMD	2.2 Ω	1%	0805	YAGEO	RC0805FR-072R2L	Yes
RLLD	1	Resistor SMD	43 k Ω	1%	0805	YAGEO	RC0805FR-0743KL	Yes
R _{MIN_TOFF}	1	Resistor SMD	22 k Ω	1%	0805	YAGEO	RC0805FR-0722KL	Yes
R _{MIN_TON} , R _{TRIG_PD}	2	Resistor SMD	10 k Ω	1%	0805	YAGEO	RC0805FR-0710KL	Yes
RSNB1, RSNB2	2	Resistor SMD	NU	-	1206	-	-	Yes

NOTE: All components are Pb-Free.