

# NCV7430GEVB

## NCV7430 LIN RGB Driver Using Auto-addressing and High Current Evaluation Board User's Manual



ON Semiconductor®

<http://onsemi.com>

### Description

Recent customer requests have shown there is a need for an RGB lighting driver device to operate in a fashion to allow the system to assign an address after power-up to allow component changes after the initial system assembly as an option to pre-programming prior to assembly at the automotive manufacturer.

The NCV7430 auto-addressing evaluation board uses an approach where the LIN communication bus is consecutively switched between modules after an address has been assigned.

The target application for the NCV7430 LIN RGB BIAS pin is defined for use as a thermal distribution device, but can find a use here in providing the customer with a solution for auto-addressing of the system board attached on LIN bus.

Additionally features to the board developed here allows for the demonstration of external drivers for higher current LEDs and testing of thermal compensation components as described in the NCV7430/D data sheet.

### Features

In addition to the NCV7430 part features, this evaluation board highlights the following:

- Auto-addressing
- Increased Output Current
- Temperature Compensation

The board shown in Figure 2 has the on-board LED on the bottom side of the board (U2). The external high current drivers (Q1, Q2, Q3) for external LED control are not populated.

Details of schematic contents can be found in the upper-left portion of the schematic (see Figure 4).

All boards are shipped with zero ohm resistors for D3, D4, and D5. These can be replaced by customer specific schottky diodes for thermal compensation.

**WARNING:** This board should only be used for driving **EITHER** an external LED with the NJVMJD253T4G drivers or the on-board LRTB\_G6TG LED.

## EVAL BOARD USER'S MANUAL



Figure 1. Evaluation Board – Top View

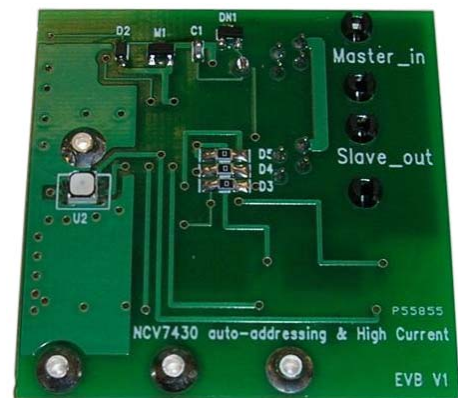

Figure 2. Evaluation Board – Bottom View



Figure 3. Evaluation Board

# NCV7430GEVB

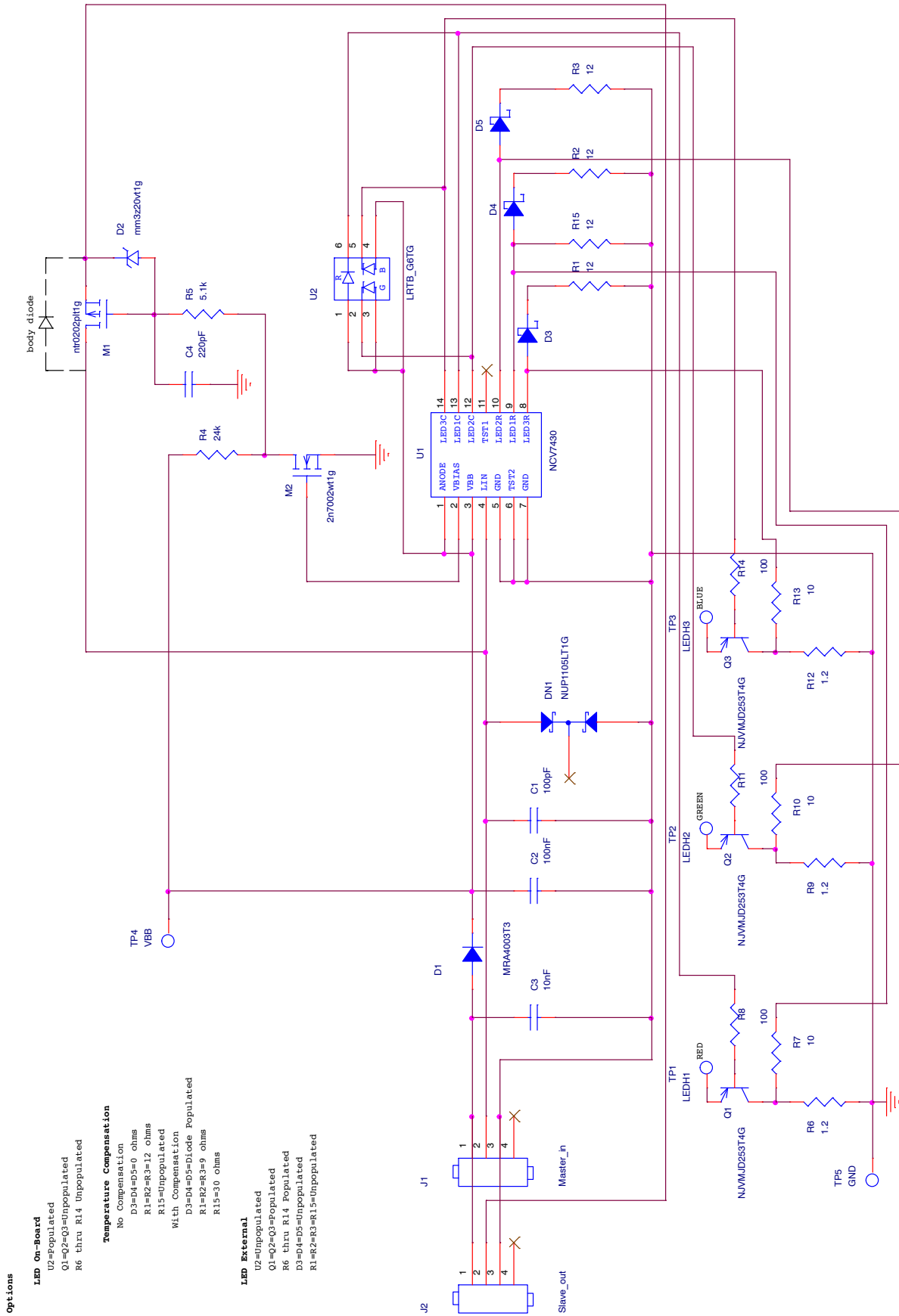
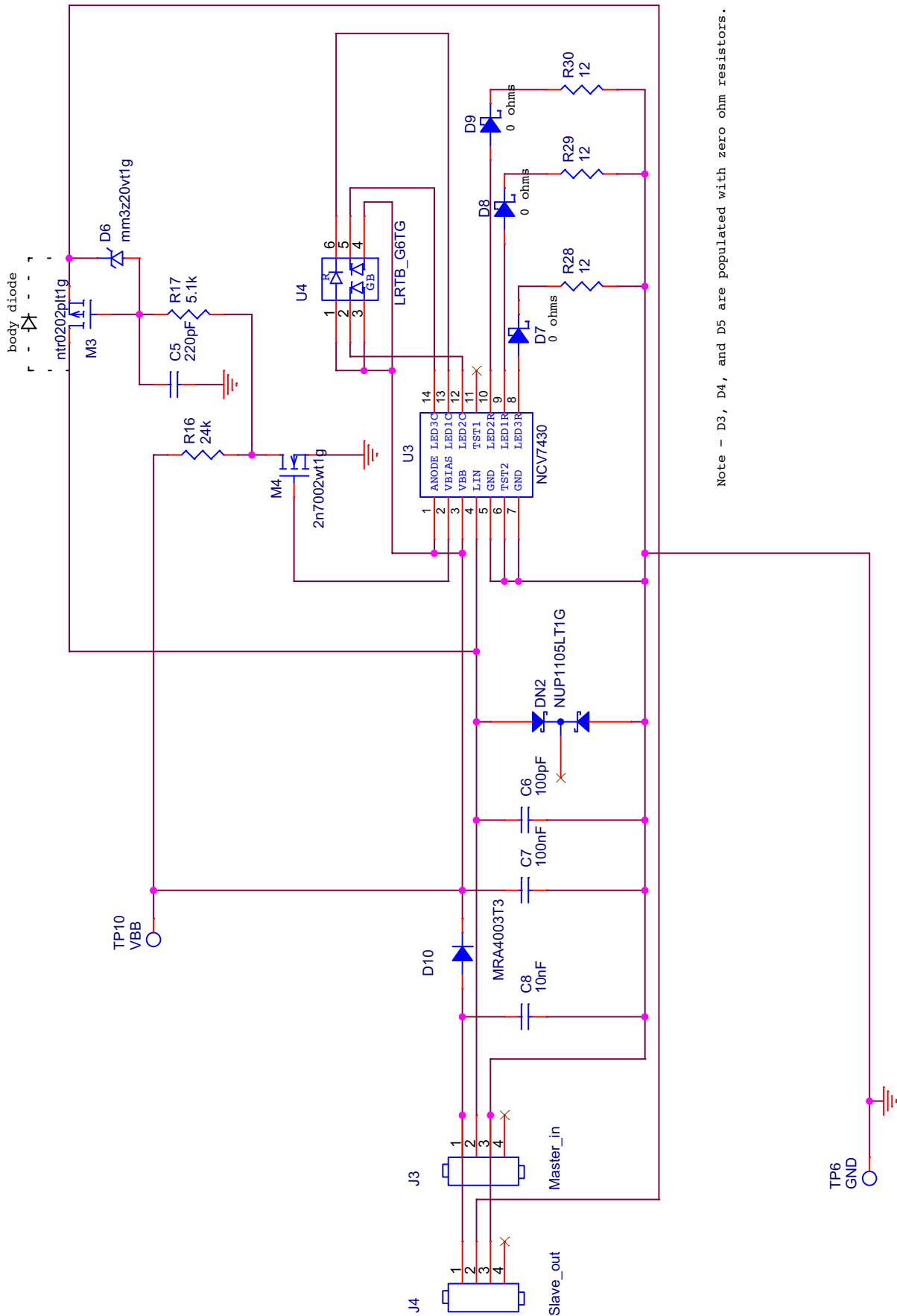

Figure 4. NCV7430 Full Evaluation Board Schematic

# NCV7430GEVB



Note - D3, D4, and D5 are populated with zero ohm resistors.

Figure 5. NCV7430 Auto Addressing Board Schematic with on board LED

# NCV7430GEVB

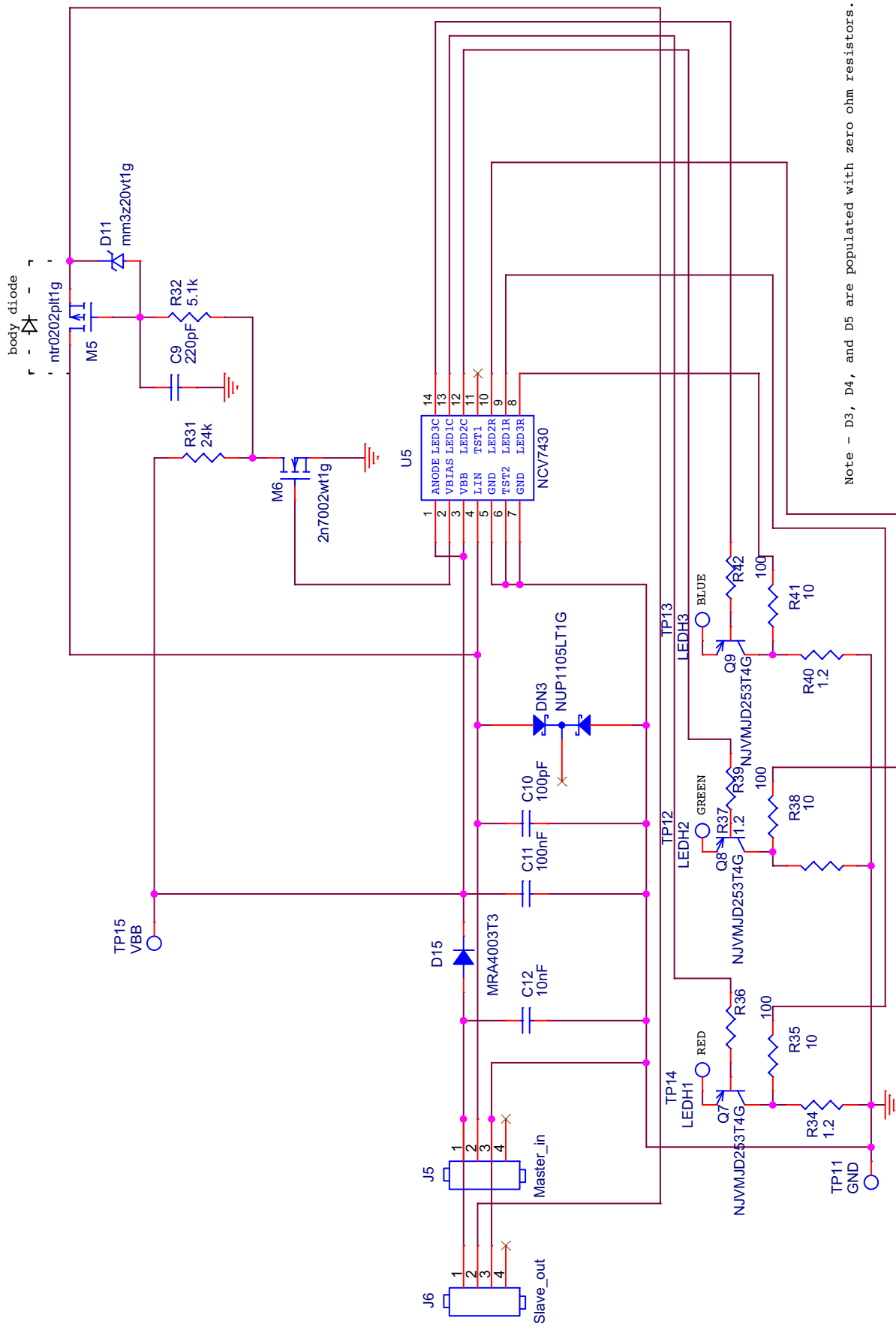

Figure 6. NCV7430 High Current Board Schematic for High Current External LED

# NCV7430GEVB

**Table 1. ABSOLUTE MAXIMUM RATINGS**

(The operation of the NCV7430 auto-addressing evaluation board works with the custom made ON Semiconductor USB2LIN board in combination with the custom GUI interface. No additional power supply is needed other than the supplied 12 V AC/DC adapter which powers the USB2LIN board through the RJ22 Connectors. An additional USB connector is used as the interface from the GUI to the USB2LIN board.)

Rating	Value	Unit
Main Supply Voltage to USB2LIN Board (AC/DC Adapter)	45 (max) 12 (typ)	V
USB Digital Supply Voltage	-0.3 to 5.5	V
NCV7430 LIN Interface Connector Pins	-45 to 45	V
4 Wire RJ11 Connector	2	A
VBB Supply Voltage (NCV7430)	-0.3 to 43	V
Junction Temperature (NCV7430)	-40 to 125	°C
Ambient Temperature (Evaluation Board)	-40 to 105	°C

Stresses exceeding Maximum Ratings may damage the device. Maximum Ratings are stress ratings only. Functional operation above the Recommended Operating Conditions is not implied. Extended exposure to stresses above the Recommended Operating Conditions may affect device reliability.

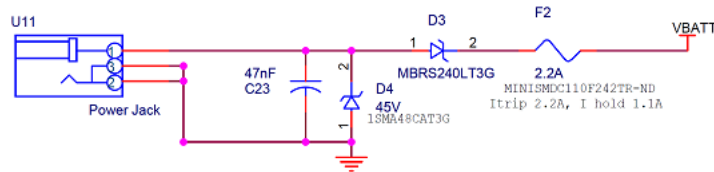

**Figure 7. USB2LIN Power Jack**

**Table 2. RECOMMENDED OPERATING CONDITIONS**

Rating	Value		Unit
	Min	Max	
External Digital Supply Voltage (VBB)	5.5	18	V
USB Supply Voltage (VBAT)	4.5	5.5	V
LED DC Output Current (with External LED using NJVMJD253T4G)	-	1 (Note 1)	A
Junction Temperature	-40	125	°C

1. Beta of the external driver at the specified operating temperature must be considered when operating at high currents in order to obtain the system design goals.

**Table 3. PIN FUNCTION DESCRIPTION**

Connector	Pin Number	Terminal Name	Description
Pin Connections (to be used with external LEDs only)	1	VBB	ANODE connection for external LEDs.
	2	Red	Red external LED CATHODE connection.
	3	Green	Green external LED CATHODE connection.
	4	Blue	Blue external LED CATHODE connection.
Test Points	5	GND	Ground
Communication and Power	J1	Master_in	Connection input from USB2LIN or preceding board in the serial chain.
	J2	Slave_out	Connection output to the next board in the serial chain.

# NCV7430GEVB

## THEORY OF OPERATION

The auto-addressing feature of this evaluation board uses the NTR0202PLT1G PFET device as a switch between modules of the LIN bus. The board is configured such that the master device connection should be made to the Master\_in node and the subsequent connection to the next sequential modules should be made from the Slave\_out.

### System Setup

Slave Device → (Module 1) [Master\_in → Slave\_out] →  
(Module 2) [Master\_in → Slave\_out]

Control of the switched node is directed by the ncv7430 device through the use of the VBIAS pin. VBIAS is low during the initial power-up of the module. The body diode of the switching transistor (NTR0202PLT1G) is sufficiently high impedance to impede communication further down the bus and orientated to provide reverse battery protection. After the 1<sup>st</sup> module has been assigned an address, the VBIAS pin goes high ultimately causing the switched transistor to turn on which allows the 2<sup>nd</sup> module to see the signal on the bus (through LIN Slave\_out).

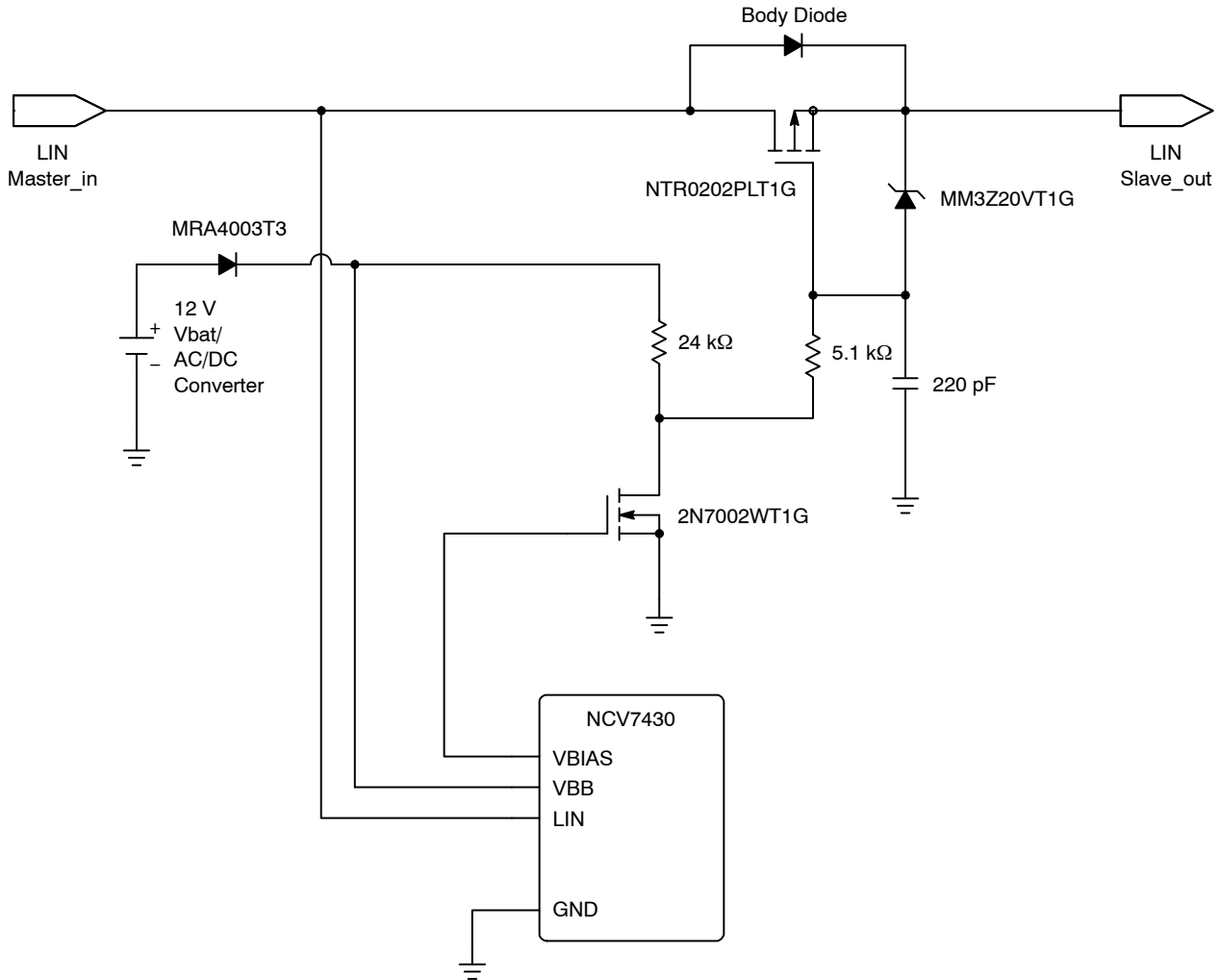

Figure 8. Auto-addressing Interface

## NCV7430GEVB

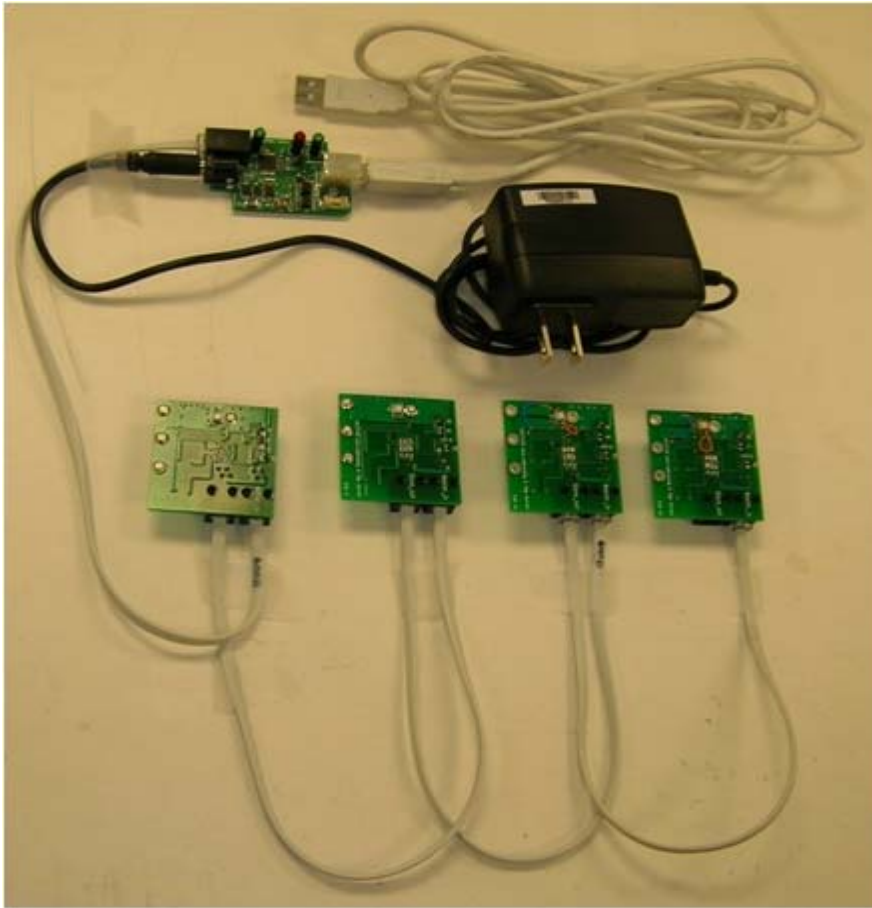

Figure 9.

### Operational Guidelines

The material necessary to successfully use the evaluation boards is listed below:

- PC Running the Latest ON Semiconductor USB2LIN GUI
- USB Cables Type A to Type B
- Interface Cables with 4 Wire RJ22 Connectors
- USB2LIN Interface Board
- NCV7430 Evaluation Board
- AC/DC 12 V Power Supply

At least 2 of the NCV7430 auto-addressing evaluation boards will be needed to demonstrate the auto-addressing feature.

1. Connect the USB cable to the computer which has the USB2LIN GUI installed and to the USB2LIN Interface Board.
2. Connect the AC/DC Power Supply to the USB2LIN Interface Board.
3. Connect the RJ22 connector from the USB2LIN Interface Board to the Master\_in on the NCV7430 auto-addressing board.
4. Connect another RJ22 connector from the Slave-out of the 1<sup>st</sup> NCV7430 auto-addressing

board to the Master\_in of a second NCV7430 auto-addressing board.

5. Initiate the GUI.
6. The initial address for the NCV7430 device is AD0 (see Figure 10).
7. Move to the Node configuration tab. Select a new address from the green matrix. Program the new address. Lock the new address with LOCKBT1 (see Figure 11).
8. The new address is programmed (see Figure 12).
9. In the middle column click the box for Ballast. Click the Program OTP button. Click the Read OTP button. The BALLAST box should now be checked (see Figure 13).
10. Select the device (AD47) and turn the device on (see Figure 14).
11. Select the Network configuration tab. Click the Scan network button. The new board in the daisy chain should appear (AD0). (see Figure 15)

Repeat the process for each additional board which requires a unique address.



# NCV7430GEVB

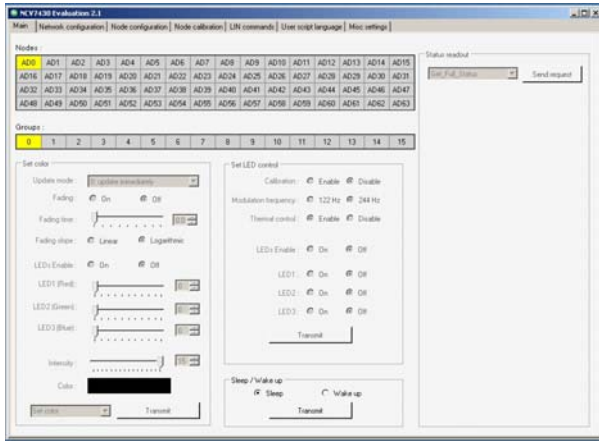

Figure 10. The Initial Address

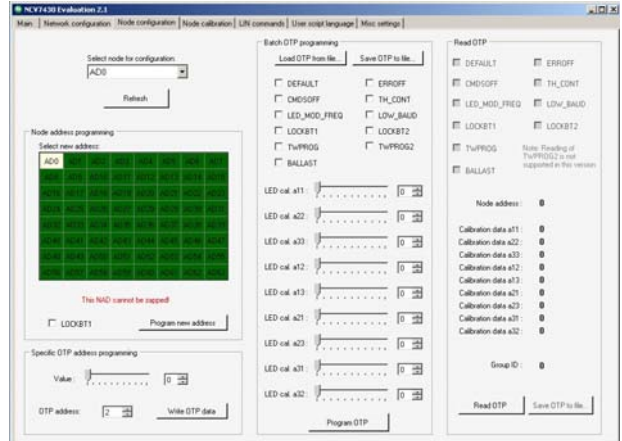

Figure 11. Lock the New Address with LOCKBT1

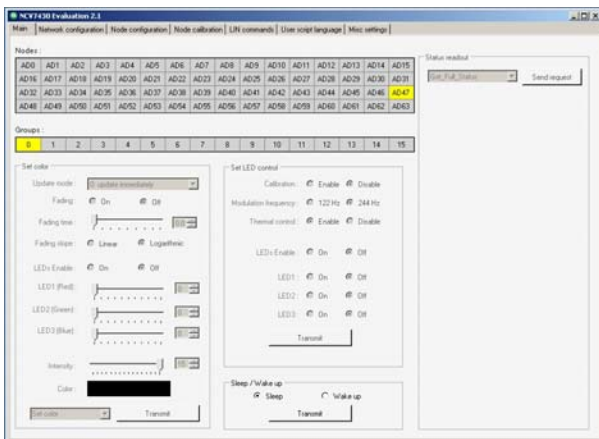

Figure 12. The New Address is Programmed

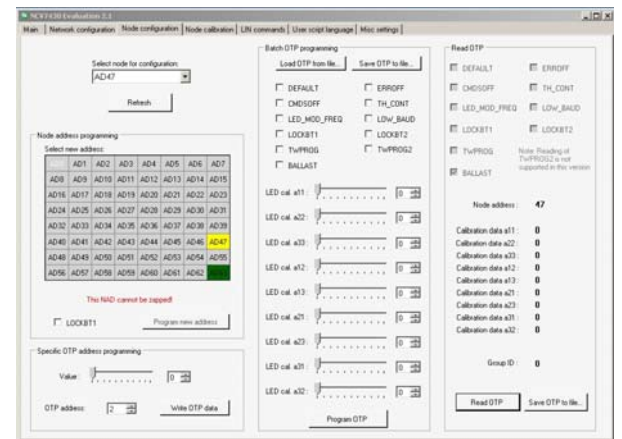

Figure 13. The BALLAST Box is Checked

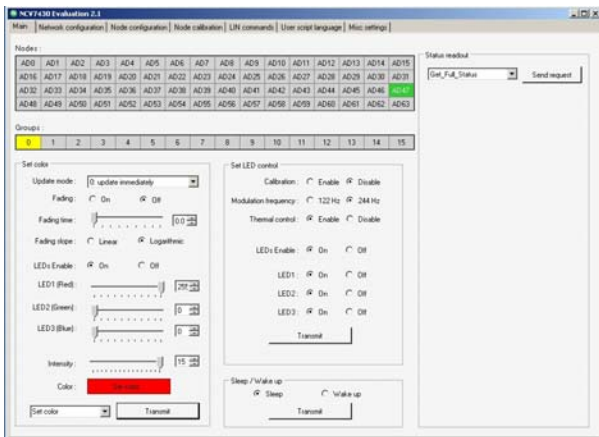

Figure 14. Select AD47 and Turn Device On

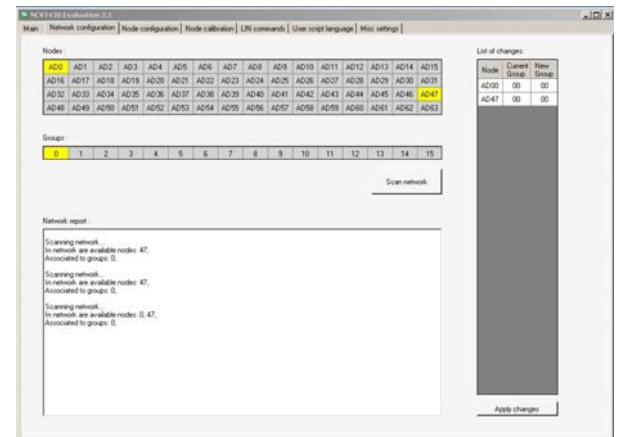

Figure 15. The New Board in the Daisy Chain Should Appear



**Increasing the LED Operating Current**

The NCV7430 device can be used as a control IC to drive an external transistor thereby resulting in a higher LED drive current. LED run current is limited to 32 mA/channel on the device. By using this current as a drive current as shown in Figure 16, the current can be increased to 32 mA times the beta of the external bipolar transistor. Additionally, the three outputs can be connected in parallel to provide a single current source which is three times the single drive capability (Reference Figure 18).

Current is programmed by the 325 mV (typ) voltage on the LEDxR pin divided by the resistor value (R3).

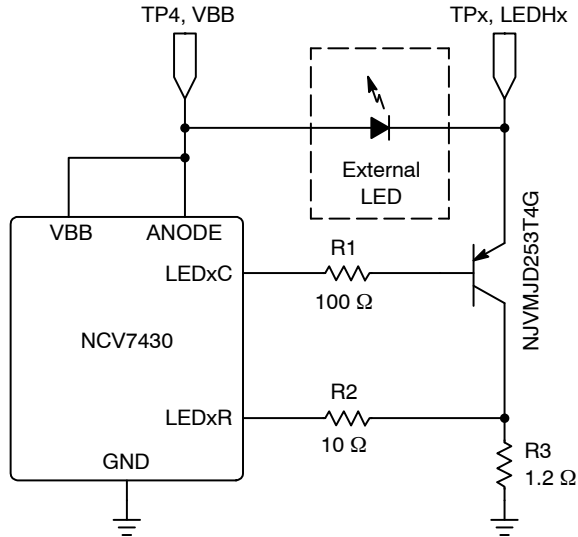

**Figure 16. Higher Current Schematic**

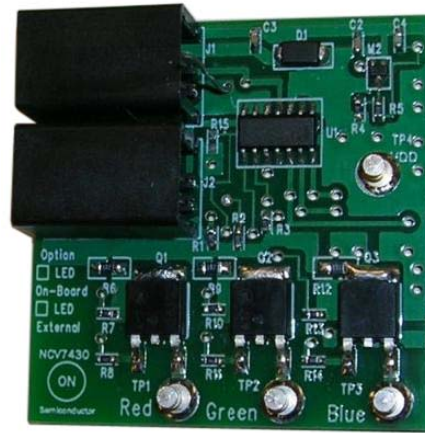

**Figure 17. High Current Operation**

**Temperature Compensation**

D3, D4, and D5 which are normally provided here as zero ohm resistors (reference schematic Figure 5, and board bottom graphic Figure 21) can be replaced by schottky diode transistors to provide compensation for thermal effects of the LEDs. A footprint for each channel is provided with an additional footprint (R15 connected from LED1R to ground) to provide placement for an additional resistor for better compensation of red LEDs. Reference the NCV7430/D datasheet for further details. An ON Semiconductor MBR0520LT1G schottky diode has been shown to provide temperature compensation for red LEDs. But choice of the schottky diode components is highly dependent on the LEDs designed into the system and placement on the PC board relative to the LED.

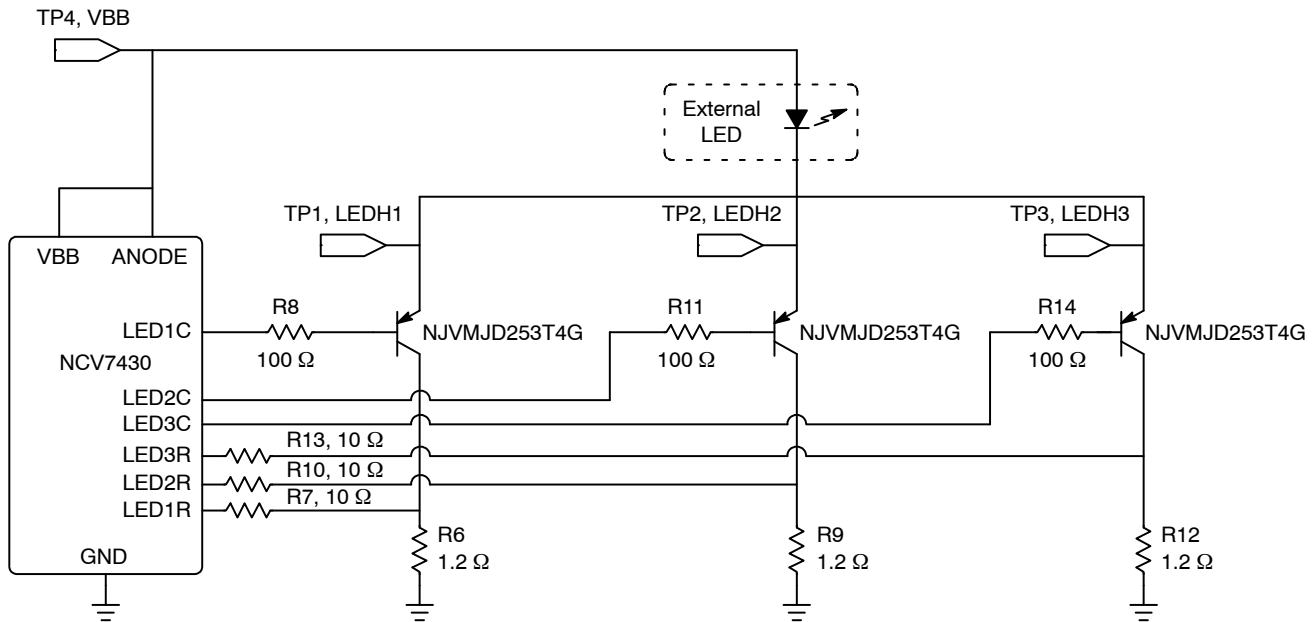

**Figure 18. Parallel Connections**

# NCV7430GEVB

## EVALUATION BOARD LAYOUT

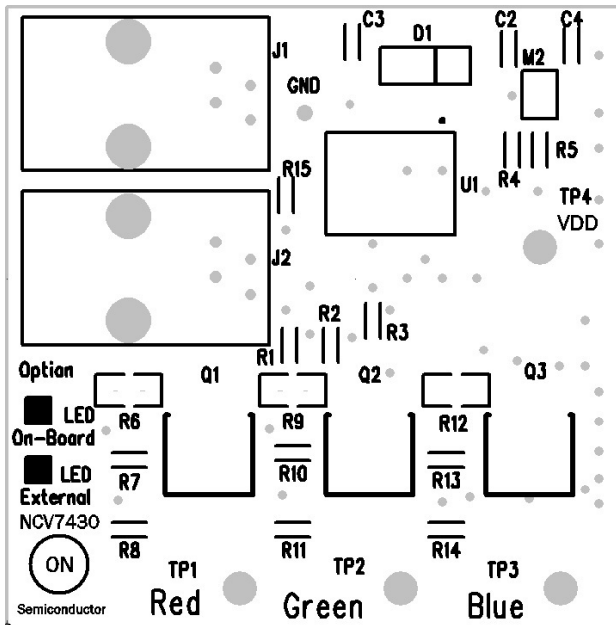

Figure 19. Silk Screen and Drill Holes

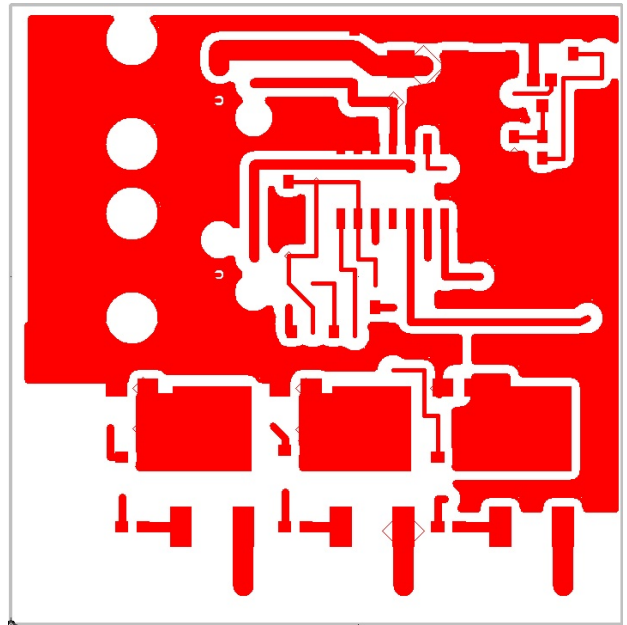

Figure 20. Copper - Top View

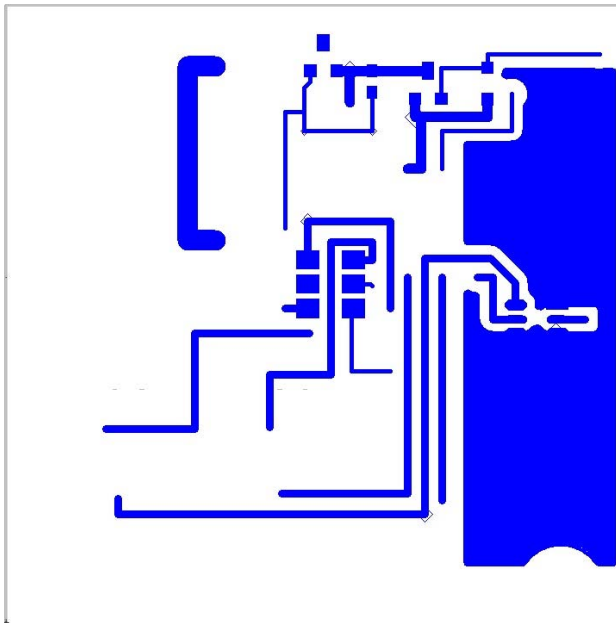

Figure 21. Copper - Bottom View

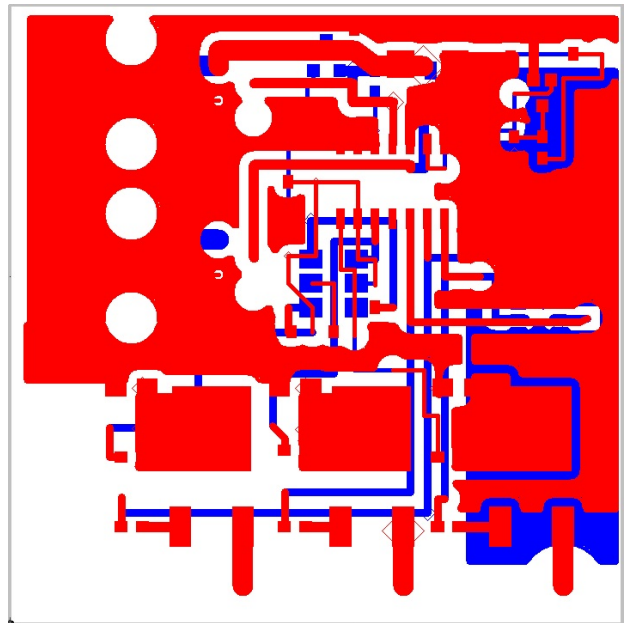

Figure 22. Board Composite

# NCV7430GEVB

**Table 4. NCV7430 AUTO-ADDRESSING EVB WITH ON-BOARD LED BILL OF MATERIALS**

Designator	Qty.	Description	Value	Tolerance	Footprint	Manufacturer	Manufacture Part Number	Substitution Allowed
U1	1	NCV7430 SOIC-14	-	-		ON Semiconductor	NCV7430D20G	No
U2	1	RGB LED		-	LRTB_G6TG	OSRAM	LRTB G6TG LRTB G6SF	Yes
C1	1	50 V LIN Filter Capacitor	100 pF	±5%	0603	Murata	GCM1885C1H101JA16D	Yes
C2	1	50 V VBB Filter Capacitor	100 nF	±10%	0603	Murata	GCM188R71H104KA57D	Yes
C3	1	50 V VBAT Filter Capacitor	10 nF	±10%	0603	Murata	GCM188R71H103KA37D	Yes
C4	1	50 V Auto-address Switch Capacitor	220 pF	±5%	0603	Murata	GCM1885C1H221JA16D	Yes
D1	1	Reverse Battery Diode		-	SMA_DIODE	ON Semiconductor	MRA4003T3	Yes
D2	1	FET Protection Diode		-	SOD_323	ON Semiconductor	MM3Z20VT1G	Yes
DN1	1	LIN Bus Protector		-	SOT23	ON Semiconductor	NUP1105LT1G	Yes
J1, J2	2	RJ22 Right Angle Socket		-	FCI_87180_044LF		87180_044LF	Yes
M1	1	Auto-address Switch		-	ntr0202plt1g	ON Semiconductor	NTR0202PLT1G	No
M2	1	Driver Switch		-	2n7002wt1g	ON Semiconductor	2N7002WT1G	Yes
R1, R2, R3, R15	4	LED Current Programming Resistors	12 Ω	±1%	0603	Vishay Dale	CRCW060312R0FKEA	Yes
R4	1	Pull-up Resistor	24 kΩ	±1%	0603	Vishay Dale	CRCW060324K0FKEA	Yes
R5	1	FET Drive Resistor	5.1 kΩ	±1%	0603	Vishay Dale	CRCW06035K10FKEA	Yes
TP1, TP2, TP3, TP4	4	High Current Connection		-	Turret	Mill Max	2501-2-00-44-00-00-07-0	Yes
D3, D4, D5	3	Jumper	0 Ω	Jumper	SOD_123	Vishay Dale	CRCW08050000Z0EA	Yes