

NCV887300LEDGEVB

NCV887300 Automotive Grade High-frequency Dimmable LED Boost Controller Evaluation Board User's Manual



ON Semiconductor®

<http://onsemi.com>

EVAL BOARD USER'S MANUAL

Description

This NCV887300 evaluation board provides a convenient way to evaluate a high-frequency LED Boost converter design. No additional components are required, other than dc supplies for the input and enable voltages. An external clock can be used to synchronize the switching frequency. It is configured as a 60 mA output current source with a 1 MHz switching frequency over the typical 6 V to 18 V automotive input voltage range. On board overvoltage protection is provided. The design is 1000:1 dimming ratio capable. The dimming frequency interface circuit may be configured to accept an 1.8 V or a 3.3 V/5 V control signal.

Key Features

- 60 mA Output Current Source
- 1000:1 Dimming Ratio
- Overvoltage Protection
- 1 MHz Switching Frequency
- Input Undervoltage Lockout
- Internal Soft-Start
- Wide Input Voltage of 6 V to 18 V
- Regulates through Load Dump Conditions
- External Clock Synchronization up to 1.1 MHz
- Automotive Grade

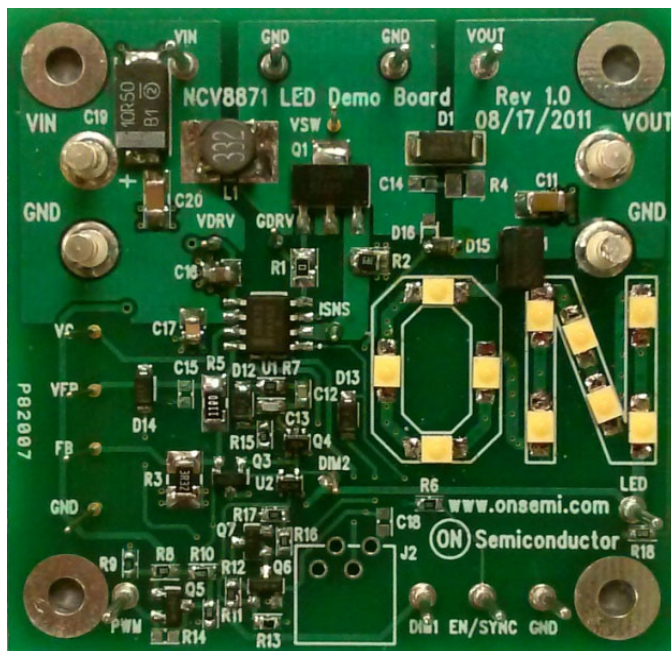

Figure 1. NCV887300 LED Evaluation Board

NCV887300LEDGEVB

Table 1. EVALUATION BOARD TERMINALS

Terminal	Function
VIN	Positive DC Input Voltage
GND	Common DC Return
VOUT	Regulated DC Output Voltage
EN/SYNC	Enable and Synchronization Input

Table 2. ABSOLUTE MAXIMUM RATINGS (Voltages are with respect to GND)

Rating	Value	Unit
DC Supply Voltage (VIN)	-0.3 to 40	V
DC Supply Voltage (EN, SYNC)	-0.3 to 6	V
Junction Temperature (NCV8902)	-40 to 150	°C
Ambient Temperature (Evaluation Board)	-40 to 105	°C

Table 3. ELECTRICAL CHARACTERISTICS ($T_A = 25^\circ\text{C}$, $6\text{ V} \leq V_{IN} \leq V_{out_LED}$, $V_{EN} = 2\text{ V}$, unless otherwise specified)

Characteristics	Conditions	Typical Value	Unit
REGULATION			
Load Current (Adjustable via R3)	R3 = 3.32 Ω	60	mA
SWITCHING			
Switching Frequency	-	1000	kHz
Soft-start Time	-	1.66	ms
SYNC Frequency Range	-	1.0–1.1	MHz
CURRENT LIMIT			
Average Current Limit (Load)	-	0.06	A
Cycle-by-cycle Current Limit (FET)	-	0.95	A
PROTECTIONS			
Input Undervoltage Lockout (UVLO)	V_{IN} Decreasing	3.05	V
Thermal Shutdown	T_A Increasing	170	°C

NCV887300LEDGEVB

Operational Guidelines

1. Connect a DC input voltage, within the 6 V to 40 V range, between VIN and GND.
2. Connect a DC enable voltage, within the 2.0 V to 5.0 V range, between EN/SYNC and GND.
3. Connect a function generator between PWM and GND. It is recommended the waveform be set to:
 - 125–200 Hz Square Typical Frequency Range
 - Low State Voltage of 0–0.8 V
 - High State of 1.8–5 V Range
 - Duty Cycle from 0.1% to 100%
4. Overvoltage may be tested by enabling the board (EN/SYNC) with jumper J1 removed.
5. Optionally:
 - for external clock synchronization, connect a pulse source between EN/SYNC and GND. The high state level should be within the 1.8 to 5 V range*, and the low state level within the –0.3 V to 0.8 V range, with a minimum pulse width of 40 ns and a frequency within the 1 MHz and 1.1 MHz range.
 - Jumper J1 should be removed if an external load is to be used instead of on-board LEDs. Input voltage operating range is valid for loads requiring $V_{out} < 40$ V.

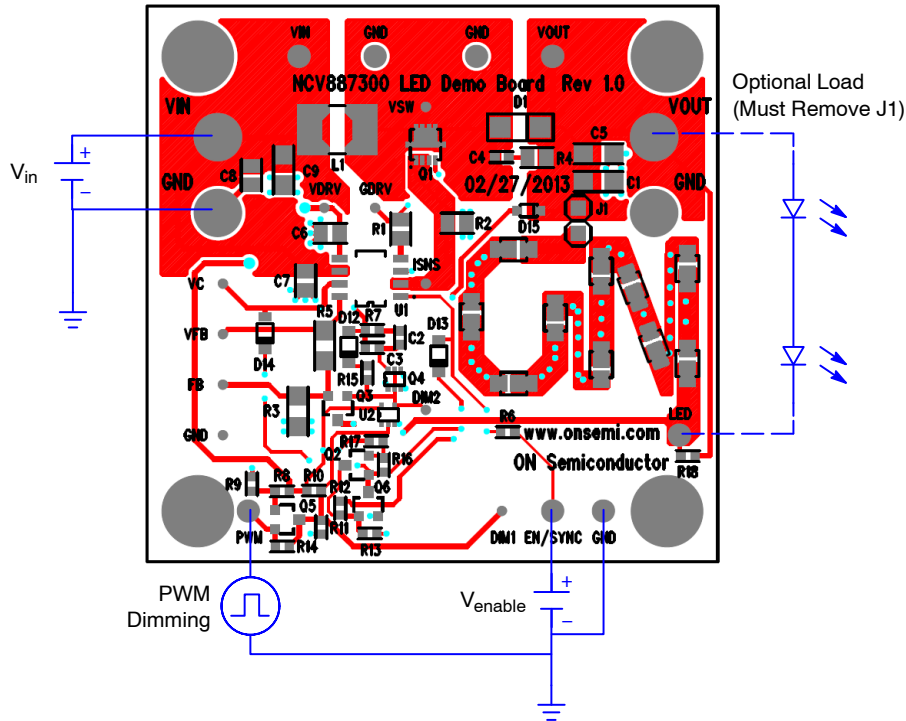

Figure 2. Evaluation Board Connections

*The dimming frequency interface circuit may be configured to accept either an 1.8 V or a 3.3 V/5 V control signal (refer to schematic). For a 1.8 V signal, use BOM and schematic as is. For a 3.3 V/5 V control signal, components R8, R9, R10, R11, Q6 are optional (R14 = 3.01K if mentioned components are removed).

NCV887300LEDGEVB

TYPICAL PERFORMANCE – START-UP

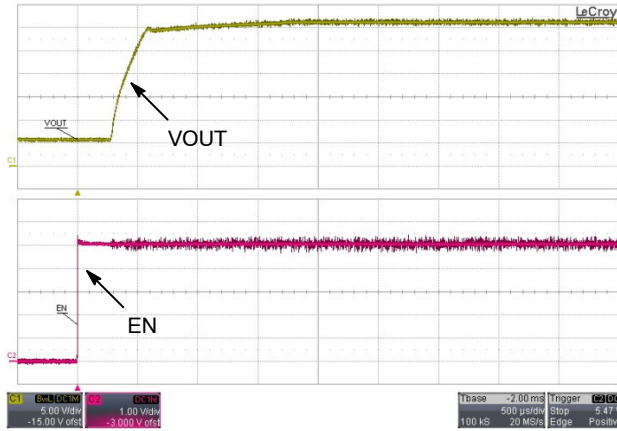

Figure 3. Typical Start-up with $V_{IN} = 6\text{ V}$, 10 LEDs/60 mA

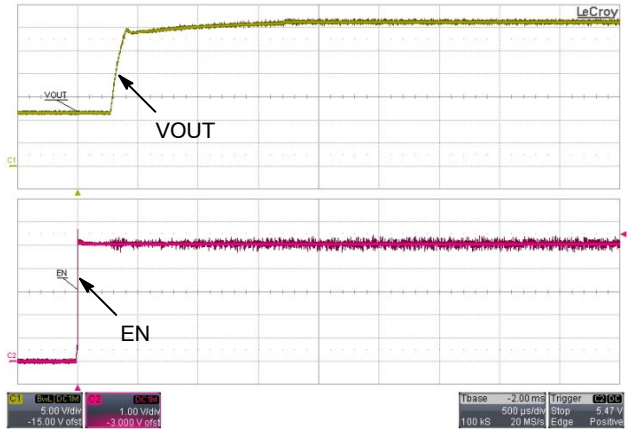

Figure 4. Typical Start-up with $V_{IN} = 12\text{ V}$, 10 LEDs/60 mA

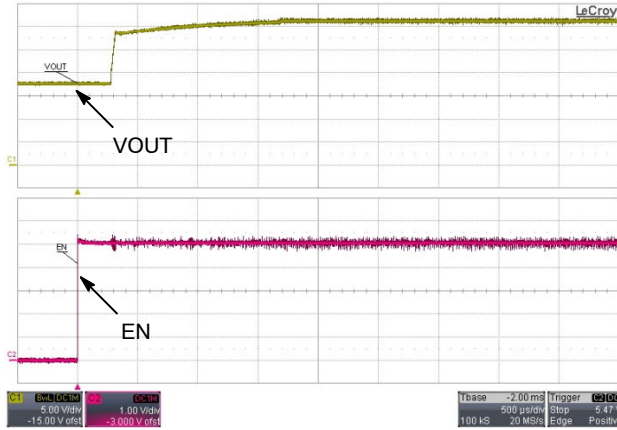

Figure 5. Typical Start-up with $V_{IN} = 18\text{ V}$, 10 LEDs/60 mA

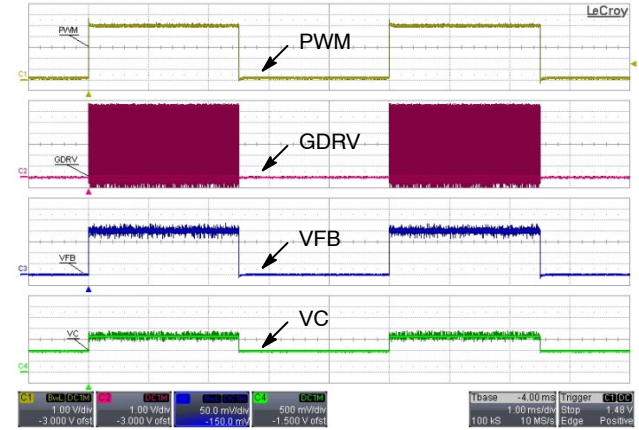

Figure 6. Converter Operation during Dimming, $V_{IN} = 12\text{ V}$, 10 LEDs/60 mA

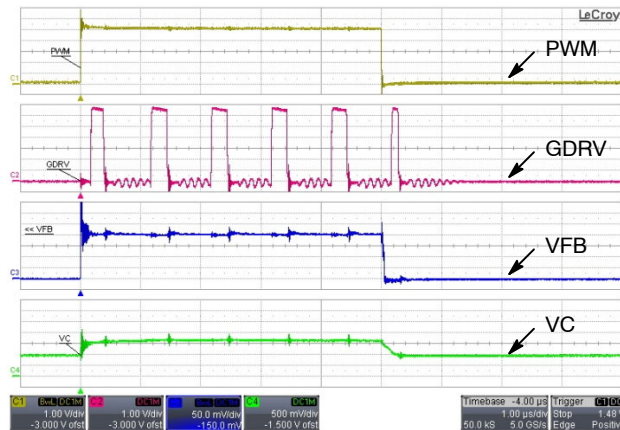

Figure 7. Converter Operation during 200 Hz 1000:1 Dimming, $V_{IN} = 12\text{ V}$, 10 LEDs/60 mA

NCV887300LEDGEVB

SCHEMATIC

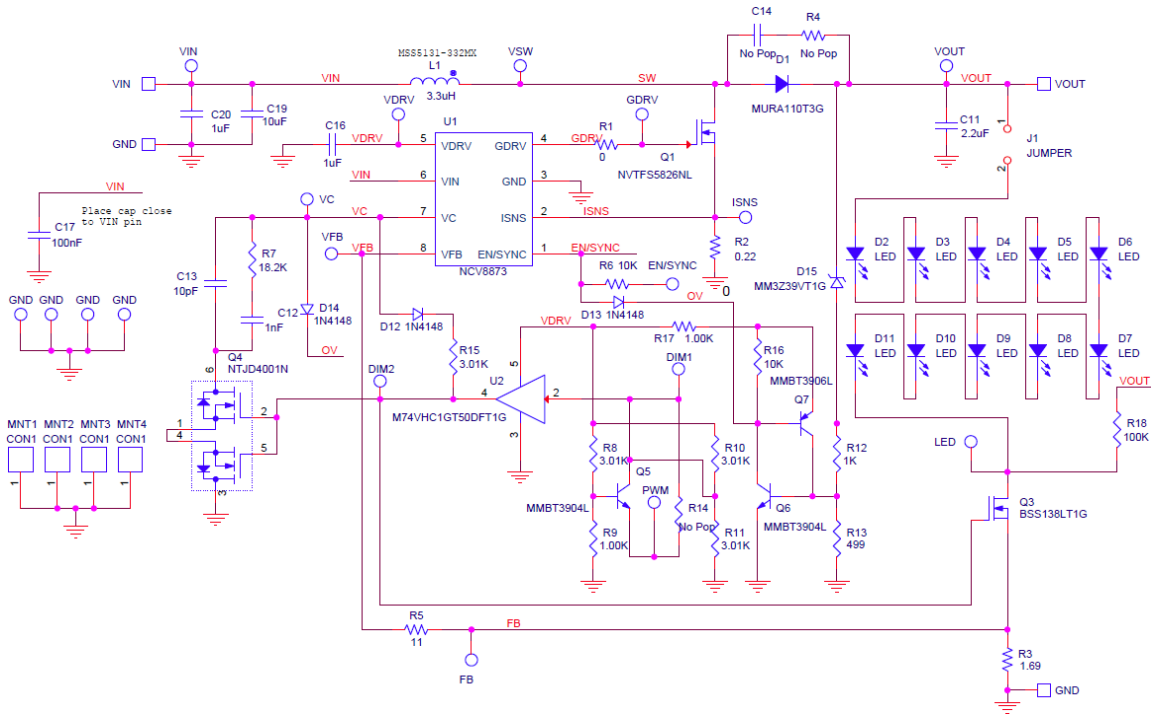

Figure 8. NCV887300 Boost LED Evaluation Board Schematic
(Applicable to PCB Rev 1.0 dated 08/11/2011)

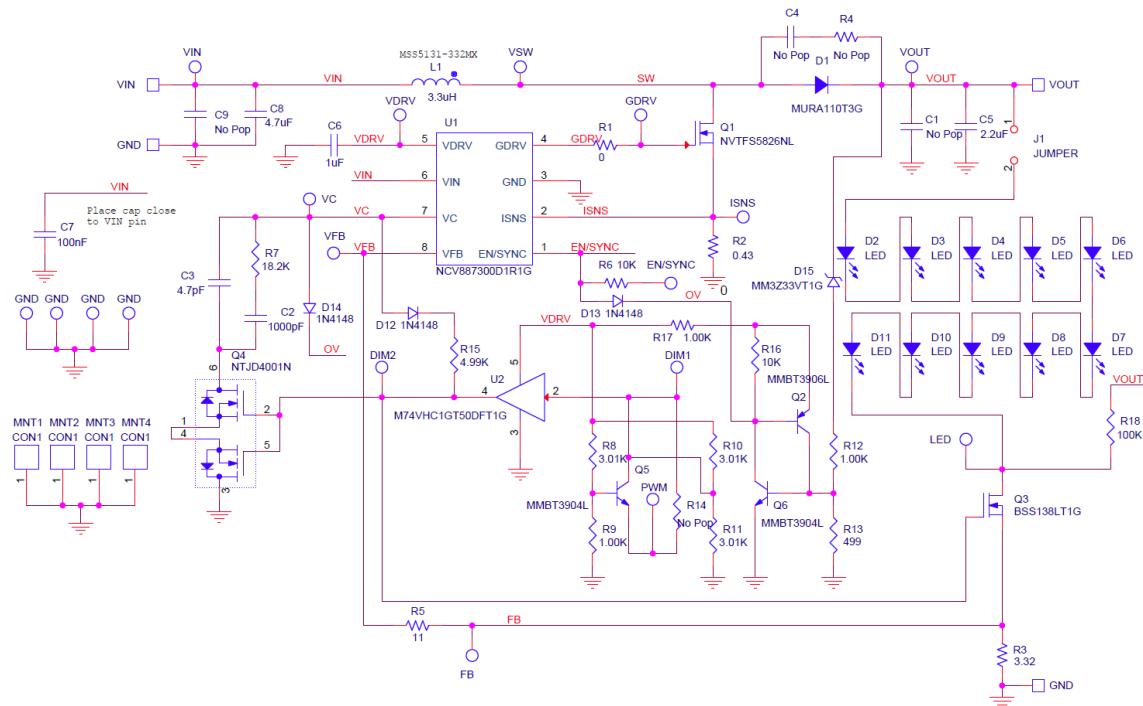

Figure 9. NCV887300 Boost LED Evaluation Board Schematic
(Applicable to PCB Rev 1.0 dated 02/27/2013)

NCV887300LEDGEVB

PCB LAYOUT

NCV887300 LED Demo Board Rev 1.0
TOP Layer 02/27/2013

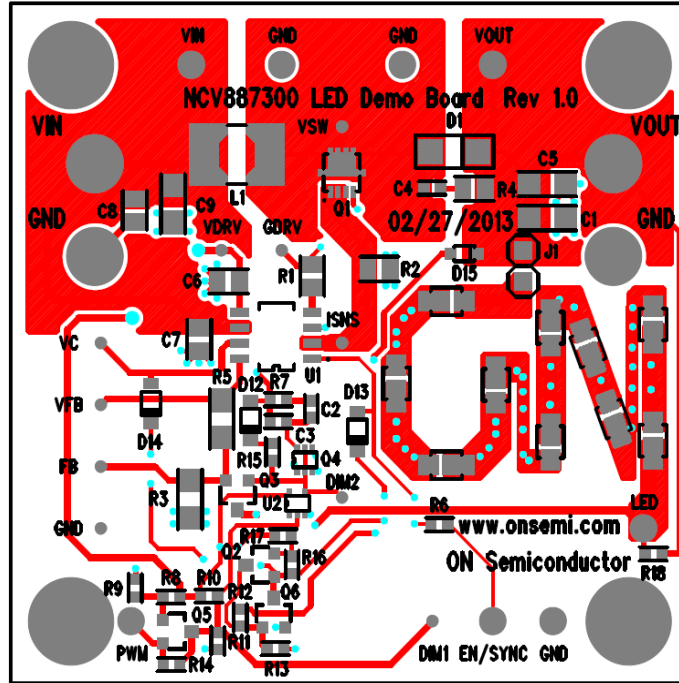

Figure 10. Top View

NCV887300 LED Demo Board Rev 1.0
BOTTOM Layer 02/27/2013

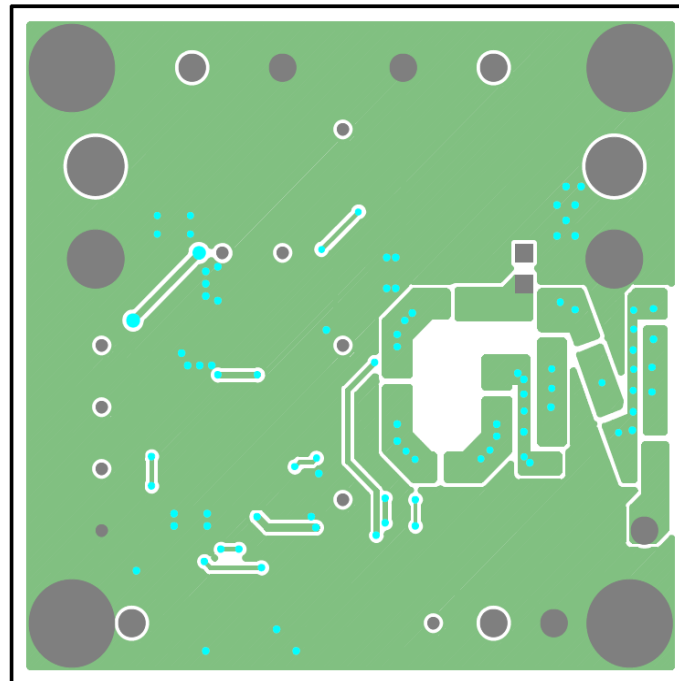

Figure 11. Bottom View

NCV887300LEDGEVB

Table 4. BILL OF MATERIALS

Reference Designator(s)	Quantity	Description	Value	Tolerance	Manufacturer	Manufacturer's Part Number
C1	1	OPEN	Do Not Populate			
C2	1	CAP CER 1000 pF 50 V X7R 0603	1000 pF, 50 V	10%	Murata Electronics North America	GCM188R71H102KA37D
C3	1	CAP CER 4.7 pF 50 V NP0 0603	4.7 pF, 50 V	5%	Murata Electronics North America	GCM1885C1H4R7CZ13D
C4	1	OPEN	Do Not Populate			
C5	1	CAP CER 2.2 μF 50 V X7R 1206	2.2 μF, 50 V	10%	Murata Electronics North America	GRM31CR71H225KA88L
C6	1	CAP CER 1 μF 16 V 10% X7R 0805	1 μF, 16 V	10%	Kemet	C0805C105K4RACAUTO
C7	1	CAP CER 0.1 μF 50 V 10% X7R 0805	0.1 μF, 50 V	10%	Murata Electronics North America	GRM21BR71H104KA01L
C8	1	CAP CER 4.7 μF 50 V 10% X5R 0805	4.7 μF, 50 V	10%	TDK Corporation	CGA4J3X5R1H475K125AB
C9	1	OPEN	Do Not Populate			
D1	1	Diode Ultra Fast 2 A 100 V SMA	100 V, 2 A	N/A	ON Semiconductor	MURA110T3G
D2 through D11	10	LED DURIS P5 29 LM 4000K	N/A	N/A	OSRAM Opto Semiconductor Inc	GW DASPA1.EC-GUHQ-5L7N-1D12
D12, D13, D14	3	Diode SGL JUNC 100 V 4.0NS MELF	N/A	N/A	ON Semiconductor	MMSD4148T1G
D15	1	Diode Zener 33 V 220 MW SOD-323	33 V	5%	ON Semiconductor	MM3Z33VT1G
J1	1	CONN HEADER 2POS.100 VERT GOLD	N/A	N/A	Molex Connector Corporation	22-28-4023
	1	CONN JUMPER SHORTING GOLD	N/A	N/A	Sullins Connector Solutions	SSC02SYAN
L1	1	SMT Power Inductor 3.3 μH 1.33 A Isat	3.3 μH	20%	Coilcraft Inc	MSS5131-332MLB
Q1	1	MOSFET N-CH 60 V 20 A μ8FL	60 V, 20 A	N/A	ON Semiconductor	NVTF5826NL
Q2	1	PNP, Small Signal, -40 V, SOT-23	-40 V, 0.2 A	N/A	ON Semiconductor	MMBT3906LT1G
Q3	1	MOSFET 50 V 200 mA 3.5 Ω N-channel SOT-23	50 V, 0.2 A	N/A	ON Semiconductor	BSS138LT1G
Q4	1	MOSFET 30 V 250 mA 1.5 Ω Dual N-channel	30 V, 0.25 A	N/A	ON Semiconductor	NTJD4001N
Q5, Q6	2	NPN, Small Signal, 40 V, SOT-23	40 V, 0.2 A	N/A	ON Semiconductor	MMBT3904LT1G
R1	1	RES 0.0 Ω 1/8 W 0805 SMD	0 Ω	JUMPER	Vishay/Dale	CRCW08050000Z0EA
R2	1	RES 0.43 Ω 1/4 W 1% 0805 SMD	0.43 Ω	1%	Rohm Semiconductor	MCR10EZHF430
R3	1	RES 3.32 Ω 1/4 W 1% 1206 SMD	3.32 Ω	1%	Vishay/Dale	CRCW12063R32FKEA
R4	1	OPEN	Do Not Populate			
R5	1	RES 11.0 Ω 1/4 W 1% 1206 SMD	11 Ω	1%	Vishay/Dale	CRCW120611R0FKEA
R6, R16	2	RES 10 kΩ 1/10 W 1% 0603 SMD	10.0 kΩ	1%	Vishay/Dale	CRCW060310K0FKEA
R7	1	RES 18.2 kΩ 1/10 W 1% 0603 SMD	18.2 kΩ	1%	Vishay/Dale	CRCW060318K2FKEA
R8, R10, R11	3	RES 3.01 kΩ 1/10 W 1% 0603 SMD	3.01 kΩ	1%	Vishay/Dale	CRCW06033K01FKEA
R9, R12, R17	3	RES 1.00 kΩ 1/10 W 1% 0603 SMD	1.00 kΩ	1%	Vishay/Dale	CRCW06031K00FKEA
R13	1	RES 499 Ω 1/10 W 1% 0603 SMD	499 Ω	1%	Vishay/Dale	CRCW0603499RFKEA
R14	1	OPEN	Do Not Populate			

NCV887300LEDGEVB

Table 4. BILL OF MATERIALS (continued)

Reference Designator(s)	Quantity	Description	Value	Tolerance	Manufacturer	Manufacturer's Part Number
R15	1	RES 4.99 kΩ 1/10 W 1% 0603 SMD	4.99 kΩ	1%	Vishay/Dale	CRCW06034K99FKEA
R18	1	RES 100 kΩ 1/10 W 1% 0603 SMD	100 kΩ	1%	Vishay/Dale	CRCW0603100KFKEA
TP1, TP4, TP7, TP14, TP16, TP17, TP20, TP22	8	PIN INBOARD .42" HOLE 1000/PKG	N/A	N/A	Vector Electronics	K24C/M
TP2, TP3, TP5, TP6, TP8, TP9, TP15, TP18, TP19, TP21	10	CICRUIT PIN PRNTD .020" D .425" L	Do Not Populate		Mill-Max Manufacturing Corp.	3128-2-00-15-00-00-08-0
TP10, TP11, TP12, TP13	4	TERM SOLDER TURRET .219" .109" L	N/A	N/A	Mill-Max Manufacturing Corp.	2501-2-00-44-00-00-07-0
U1	1	Automotive Non-Sync Boost Controller	N/A	N/A	ON Semiconductor	NCV887300D1R2G
U2	1	IC BUFF CMOS LVL/SFTR N-I SOT353	N/A	N/A	ON Semiconductor	M74VHC1GT50DFT1G
MNT1, 2, 3, 4	4	Hex Spacer 4-40 1/4" Zinc Plated Steel 3/8"	N/A	N/A	McMaster-Carr	93620A431
	4	Hex Nut 4-40 1/4" Zinc Plated Steel	N/A	N/A	McMaster-Carr	90480A005