

## Overview

KEMET's piezoelectric ceramics ND series are disc-shaped piezoceramics that use original high-performance piezoelectric materials.

These products are based on the principle of the piezoelectric effect that generates a charge in response to pressure and an inverse piezoelectric effect that generates strain in response to voltage.

## Applications

- Vibratory feeder
- Ultrasonic cleaning machine
- Ultrasonic levitation
- Ultrasonic flow and level meter
- Ultrasonic distance sensor
- Load sensor, impact sensor

## Benefits

- N6 material has a high coupling coefficient, high  $Q_m$ , and low  $\tan\delta$ , suitable for high power applications
- N21 material has a high coupling coefficient and a large  $g$ -constant, suitable for sensing applications
- Operating temperature range from  $-20^{\circ}\text{C}$  to  $+60^{\circ}\text{C}$
- RoHS/REACH compliant

ND\*\*\*\*N6

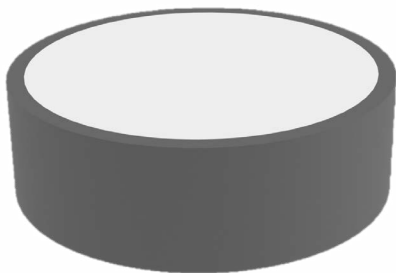

ND\*\*\*\*N21

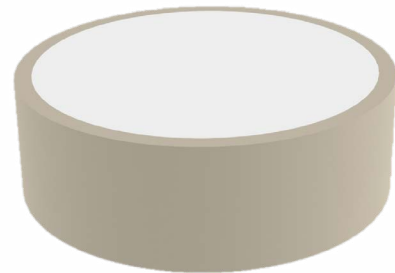

## Ordering Information

ND	10	X3	N21
Series	Ceramic Outer Diameter (mm)	Thickness Dimension (mm)	Ceramic Material Name
ND	10 = $\varnothing$ 10 mm 18 = $\varnothing$ 18 mm	X2 = 2 mm X3 = 3 mm	N6 = N6 material N21 = N21 material

## Dimensions in mm

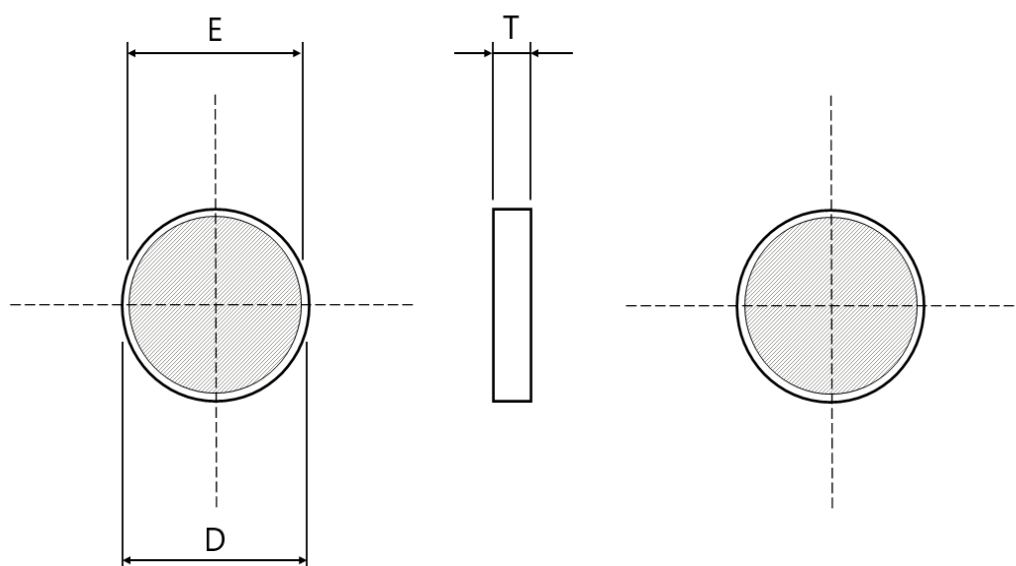

Part Number	Diameter D (mm)	Thickness T (mm)	Electrode Diameter E (mm) <sup>1</sup>
ND10X2N6	10 ±0.1	2 ±0.1	9.2
ND10X3N6	10 ±0.1	3 ±0.1	9.2
ND18X2N6	18 ±0.1	2 ±0.1	17.5
ND18X3N6	18 ±0.1	3 ±0.1	17.5
ND10X2N21	10 ±0.1	2 ±0.1	9.2
ND10X3N21	10 ±0.1	3 ±0.1	9.2
ND18X2N21	18 ±0.1	2 ±0.1	17.5
ND18X3N21	18 ±0.1	3 ±0.1	17.5

<sup>1</sup> Electrode diameter for reference value only. Values not guaranteed.

## Environmental Compliance

All KEMET Piezoceramics are RoHS and REACH Compliant.

Article 33(1) of the REACH Regulation states that manufacturers and importers of articles (products) are required to notify their customers of the presence of any Substances of Very High Concern (SVHC) in their products exceeding 0.1% by weight and provide instructions on safe use of the product.

KEMET Corporation reports regarding the Article 33(1) of REACH Regulation as follows:

1. Applicable Product:

Piezoceramics (ND Series).

2. Report for content of REACH SVHC list:

The product(s) above contain a substance by more than 0.1wt% per product weight that was published in the 8th update of the REACH SVHC substances (December 19, 2012).

3. Regarding safety of the piezoelectric ceramics :

The piezoceramics that is used in this product becomes ceramic by sintering powder containing PZT as a main ingredient. It is chemically stable, with minimum risks toward the human body or environment within the intended use of the product. Please note that risks could occur in the case of inhalation or accidental oral uptake of powder ceramics.

4. Technical product information on the piezoceramics:

The manufacturing technique of the “piezoceramics” whose main ingredient is Lead Titanium Zirconium Oxide (PZT) has been established, and there is no alternative material that can exhibit superior performance than PZT at this moment. Please note that the piezoceramics is listed as an exempt on RoHS (2011/65/EU) Annex III (7c.1).

5. Responsibility of the piezoceramics manufacturers:

Piezoceramics manufacturers report information regarding PZT containment in their products to the customers to obey the article 33 of the REACH regulation.



## Performance Characteristics

### Characteristics of Piezoelectric Ceramic Materials

Item		N6 Material	N21 Material
Relative Dielectric Constants	$\epsilon_{33}^T/\epsilon_0$	1,400	1,800
	$\epsilon_{11}^T/\epsilon_0$	1,350	2,000
Dielectric Loss	$\tan\delta$	0.3%	2.0%
Frequency Constants	$N_1$ (Radial)	2,160 Hz·m	1,960 Hz·m
	$N_2$ (Lengthwise)	1,600 Hz·m	1,410 Hz·m
	$N_3$ (Longitudinal)	1,510 Hz·m	1,310 Hz·m
	$N_4$ (Thickness)	1,960 Hz·m	1,940 Hz·m
	$N_5$ (Share)	970 Hz·m	860 Hz·m
Electromechanical Coupling Factors	$K_r$	55%	62%
	$K_{31}$	34%	38%
	$K_{33}$	68%	73%
	$K_t$	55%	52%
	$K_{15}$	71%	77%
Piezoelectric Constants	$d_{31}$	$-133 \times 10^{-12}$ m/V	$-198 \times 10^{-12}$ m/V
	$d_{33}$	$302 \times 10^{-12}$ m/V	$417 \times 10^{-12}$ m/V
	$d_{15}$	$419 \times 10^{-12}$ m/V	$711 \times 10^{-12}$ m/V
	$g_{31}$	$-10.4 \times 10^{-3}$ Vm/N	$-12.1 \times 10^{-3}$ Vm/N
	$g_{33}$	$23.5 \times 10^{-3}$ Vm/N	$25.4 \times 10^{-3}$ Vm/N
	$g_{15}$	$45.1 \times 10^{-3}$ Vm/N	$41.0 \times 10^{-3}$ Vm/N
Compliances	$S_{11}^E$	$12.7 \times 10^{-12}$ m <sup>2</sup> /N	$16.5 \times 10^{-12}$ m <sup>2</sup> /N
	$S_{33}^E$	$15.4 \times 10^{-12}$ m <sup>2</sup> /N	$19.9 \times 10^{-12}$ m <sup>2</sup> /N
	$Y_{33}^E$	$6.5 \times 10^{10}$ N/m <sup>2</sup>	$5.0 \times 10^{10}$ N/m <sup>2</sup>
	$Y_{11}^E$	$7.9 \times 10^{10}$ N/m <sup>2</sup>	$6.1 \times 10^{10}$ N/m <sup>2</sup>
Poisson's Ratio	$\delta$	0.32	0.34
Mechanical Quality Factor	Qm	1,500	75
Curie Temperature	Tc	325°C	330°C
Density	$\rho$	7.77	7.82
Temperature Coefficient	Tk(fr) (-20°C to +20°C)	200 ppm/°C	-340 ppm/°C
	Tk(fr) (+20°C to +60°C)	100 ppm/°C	-175 ppm/°C
	Tk(C) (-20°C to +20°C)	2,200 ppm/°C	3,800 ppm/°C
	Tk(C) (+20°C to +60°C)	4,300 ppm/°C	4,700 ppm/°C
Aging Rate	fr	0.3%/10 Years	0.1%/10 Years
	C	-1%/10 Years	-2%/10 Years

Each material constant may change due to the influence of the product shape.

**Table 1 – Ratings & Part Number Reference**

Part Number	Radial Resonance Frequency (kHz)	Capacitance (pF)	Operating Temperature Range	Weight (g)
ND10X2N6	216 ±5%	480 ±20%	-20°C to +60°C	1.2
ND10X3N6	207 ±5%	320 ±20%	-20°C to +60°C	1.8
ND18X2N6	120 ±5%	1,610 ±20%	-20°C to +60°C	4.0
ND18X3N6	120 ±5%	1,080 ±20%	-20°C to +60°C	6.0
ND10X2N21	196 ±5%	590 ±20%	-20°C to +60°C	1.2
ND10X3N21	190 ±5%	400 ±20%	-20°C to +60°C	1.8
ND18X2N21	109 ±5%	2,000 ±20%	-20°C to +60°C	4.0
ND18X3N21	109 ±5%	1,370 ±20%	-20°C to +60°C	6.0

## Packaging

Part Type	Packaging Type	Pieces per Box
ND	Vacuum Bag	1

## Handling Precautions

### Polarity Display

+ is displayed on the + pole side of the polarization treatment.

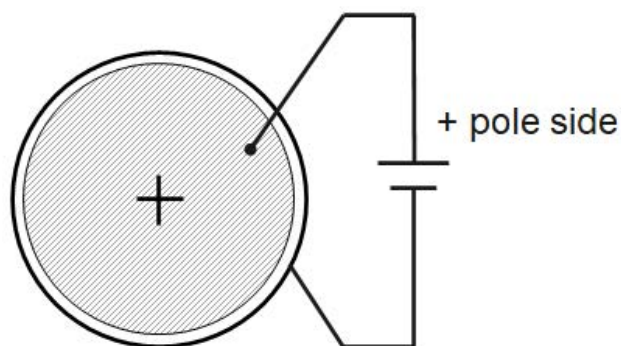

No sign is displayed on the - pole side of the polarization treatment.

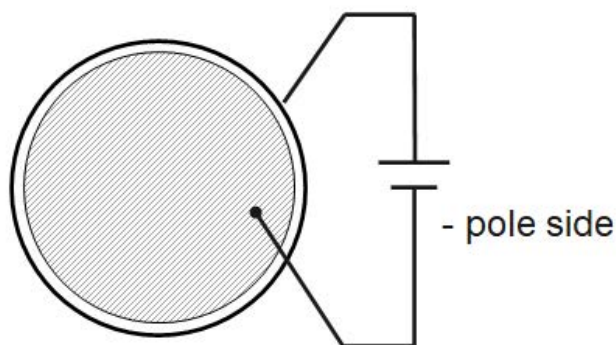

## Export Control

### For customers in Japan

For products which are controlled items subject to the "Foreign Exchange and Foreign Trade Law" of Japan, the export license specified by the law is required for export.

### For customers outside Japan

Piezoelectric Transducers should not be used or sold for use in the development, production, stockpiling or utilization of any conventional weapons or mass-destructive weapons (nuclear weapons, chemical or biological weapons, or missiles), or any other weapons.