

Draft Specification

- Part No. : **NFR.03**
- Product Name : Radius External Bracket NFC Antenna with ACH Connector and 5 meter cable
- Features : External Wall Mount NFC Antenna
Frequency: 13.56MHz
IP67 Waterproof
Cable: 5M AWG28 Cable
Connector: ACH (F)
Dimension: 75*75*27.3mm
RoHS Compliant



1. Introduction

The Radius NFR.03 antenna is an external bracket-mount NFC (Near Field Communication) antenna for use with NFC readers, enabling your device to execute point-to-point data transmission without contact. This design is matched for optimal performance with typical NFC chipsets.

Typical Applications include:

- Contactless Payment
- RFID
- Security

The IP67 waterproof enclosure ensures that it can be used for both indoor and outdoor environments. With its own mounting bracket, the NFR.03 can be easily installed on a wall or metal panel. For robust performance in outdoor applications, the NFR.03 antenna and mounting bracket are protected by a heat-resistant, high-impact-resistant, UV-stabilized ASA enclosure.

A 5m 28AWG Twisted Pair cable with ACH(F) connector is connected to the housing.

Custom cable lengths or versions with an embedded RJ45 Jack for Ethernet cables are also available. Contact your regional Taoglas sales office for support.

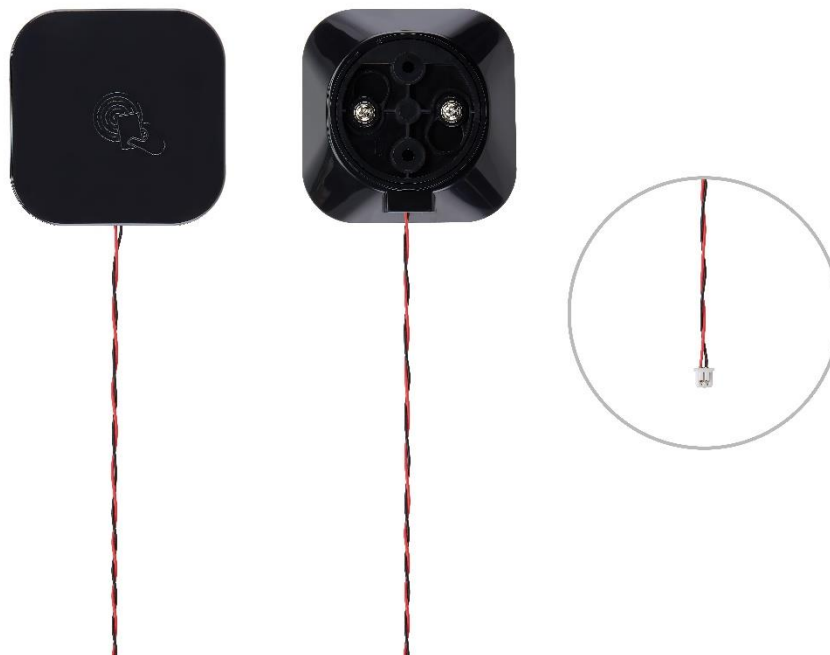

2. Specifications

Flexible PCB Near-Field Communications Reader Antenna	
Frequency	13.56 MHz
Mechanical	
Antenna Dimensions	75x75x27.3mm
IP Rating	IP67
Weight	55 g
Environmental	
Operation Temperature	-40°C to 85°C
Storage Temperature	-40°C to 85°C
Humidity	Non-condensing 65°C 95% RH

3. Antenna Application

3.1. Test Setup

A test fixture is used to measure the maximum interrogation distance. The NFR.03 antenna is connected to a NFC evaluation board and then placed on the fixed part of the fixture.

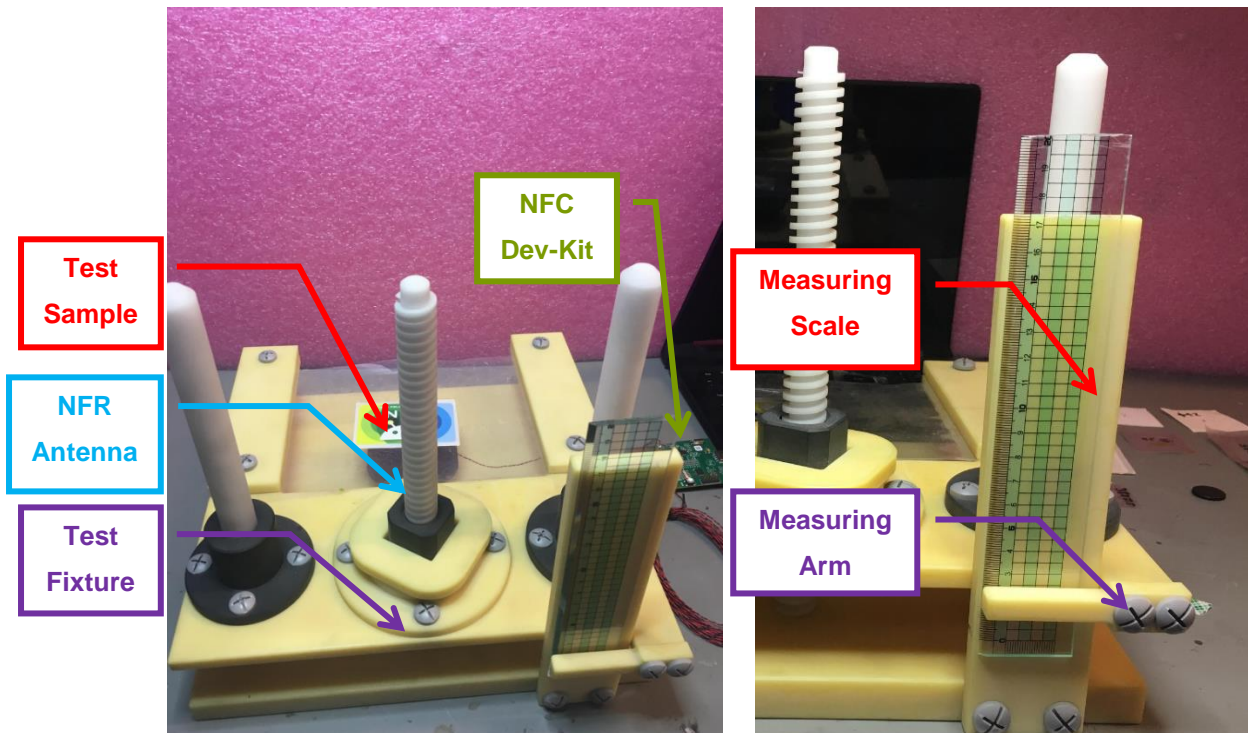

Figure 1. Test setup and parts identification.

The test sample is placed on a thin sheet of plastic connected to the moveable part of the fixture. Then the distance is carefully adjusted until the reader can no longer read the sample, thus the maximum interrogation distance is displayed in the ruler.

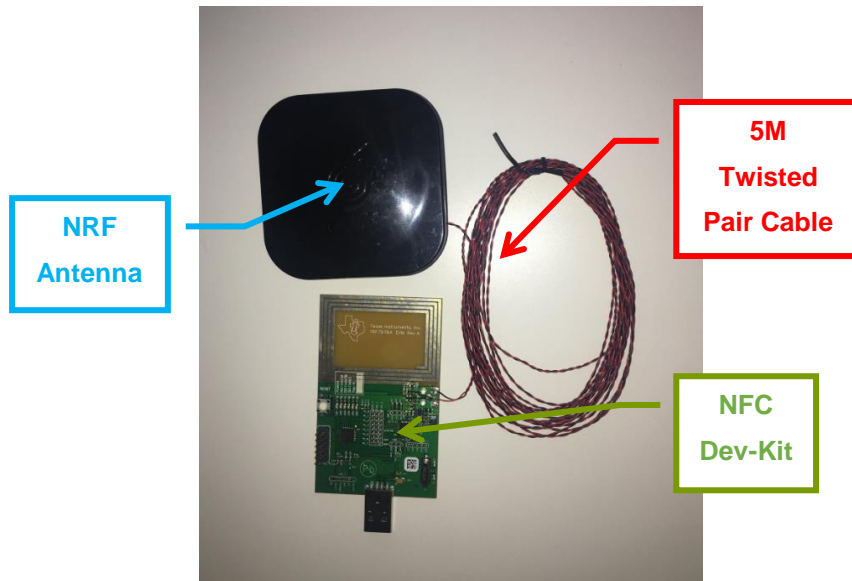

Figure 2. NFC Dev-Kit and Taoglas NFR antenna.

3.2. RFID tags used for test

A total of 10 RFID tags were used to measure the interrogation distances. **Figure 3** shows type 1, type 2 and type 4 tags, respectively.



Figure 3. NFC tags used for testing: types 1, 2, and 4.

Type 1 tag is based on ISO/IEC 14443A standard and has 512 bytes of memory.
 Type 2 tag is based on ISO/IEC 14443A standard and has 192 bytes of memory.
 Type 4 is based on ISO / IEC 14443A 1-4 compliant and has 2K of memory.

Figure 4 shows Tag-it HF-I RFID tags from Texas Instruments: RI-102-112, RI-I11-112, RI-I03-112, RI-I16-112, Button and RI-I17-112.

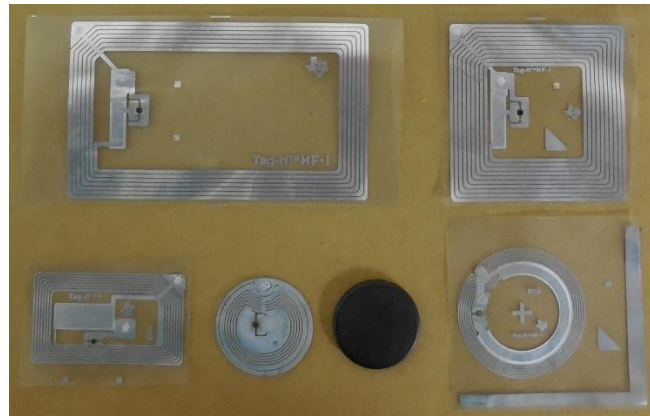

Figure 4. TI NFC tags used for testing.

The Tag-it HF-I Plus Transponder Inlay family of Texas Instruments RFID is based on the ISO/IEC 15693 standard for contactless integrated circuit cards (vicinity cards) and ISO/IEC 18000-3 standard for item management.

3.3. Matching

The interrogation distances presented here were taken with the antenna connected directly to the evaluation boards with the default matching circuit. This is not necessarily the optimal matching circuit that could be designed for a particular antenna. We kept the default matching of each evaluation board to minimize the number of variables in testing and keep integration as simple as possible.

As with any matching network the exact circuit and values for an optimal network depend on the combination of antenna, NFC circuit, any intervening transmission line and the environment presented to the antenna. These factors are specific to the particular end product.

As a starting point, to achieve the read range results presented here, use the matching network detailed in the schematic of the evaluation board for your particular NFC chip and keep the antenna free of any obstruction. Once you can demonstrate successful reads you can then optimize performance as desired.

3.4. Test Results

A total of 10 NFC tags were selected to measure the interrogation distances using the Texas Instruments TRF7970AEVM evaluation board. The results are in **Table 1**:

Table 1. Read distance test results.

NFC Tag	Dimensions (mm.)	Interrogation Distance (mm.)
Mifare Ultralight C	80 x 50	10
Topaz512 (Type 1)	43 x 43	28
NTAG203 (Type 2)	Ø42	34
Mifare DESFire (Type 4)	80 x 50	22
Tag-it HFI Plus RI-I11-112	45 x 45	45
Tag-it HFI Plus RI-I02-112	76 x 48	77
Tag-it HFI Plus RI-I03-112	38 x 22.5	26
Tag-it HFI Plus RI-I16-112	Ø24.2	32
Tag-it HFI Plus RI-I17-112	Ø32.5	37
Button type	Ø22	33

4. Mechanical Drawing(unit: mm)

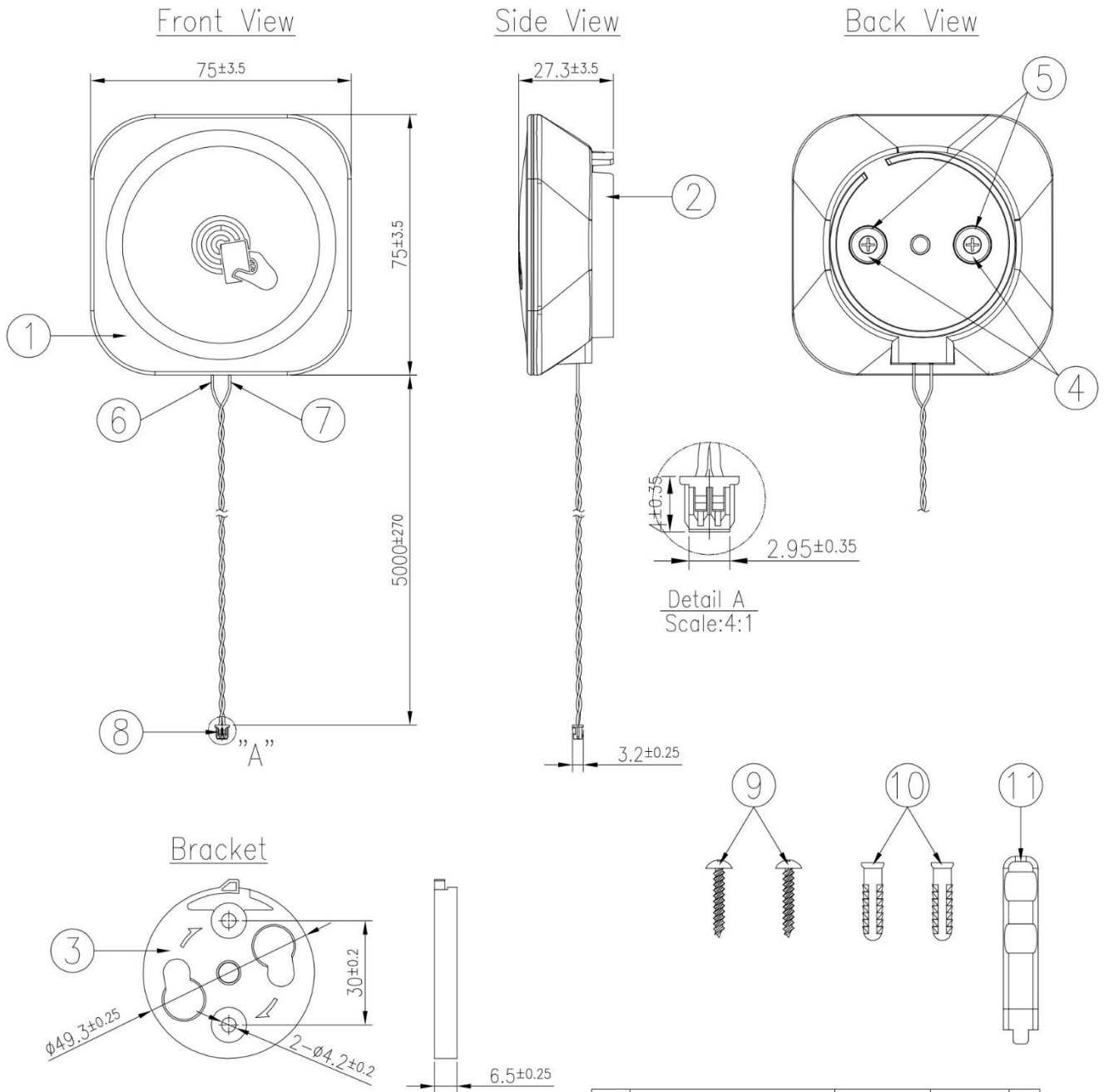

	Name	Material	Finish	QTY
1	NFR_Housing_Top	ASA	Black	1
2	NFR_Housing_Bottomx2Hole	ASA	Black	1
3	NFR_Bracket	ASA	Black	1
4	Fastening Washer	ABS+PC	Black	2
5	Screw TP1(3x8L)	Steel	Ni Plated	2
6	PVDF Cable (28AWG)	PVDF	Black	1
7	PVDF Cable (28AWG)	PVDF	Red	1
8	ACH Connector (F) (M125H-02)	Nylon	Black	1
9	Screw TP4x25L	Steel	Ni Plated	2
10	Wall mount stud 6x24L	Nylon	White	2
11	Hook_Key	ASA	Black	1

5. Packaging

1 pc NFR.03 in box
Dimensions - 94.5*82.5*36.5mm
Weight - 85g

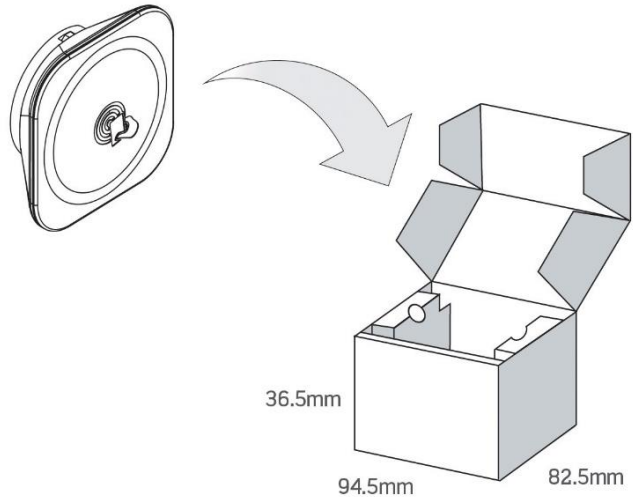

50 pcs NFR.03 in one carton
Carton Dimensions - 488*193*195mm
Weight - 4.87Kg

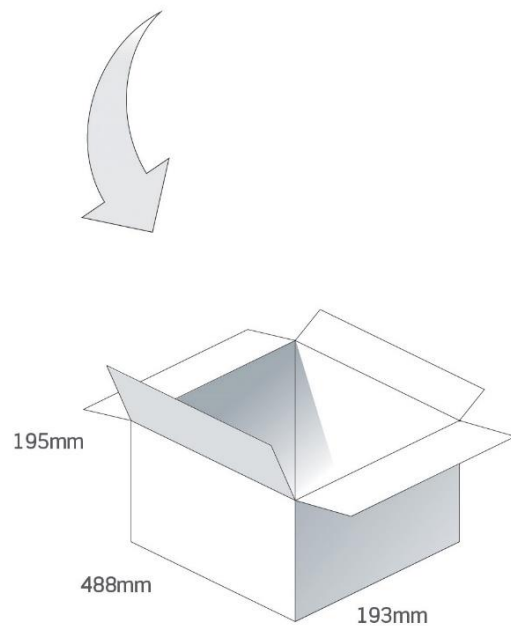

6. Installation Instructions

