

# Reference Only

Spec No. JENF243J-9103B-01

P.1/10

**CHIP NOISE FILTER NFZ5BBW□□□LZ10□**  
**Murata Standard Reference Specification [AEC-Q200]**

### 1.Scope

This reference specification applies to NFZ5BBW\_LZ10 series, Chip Noise Filter for Automotive Electronics based on AEC-Q200 except for Power train and Safety.

### 2.Part Numbering

(ex) NF Z 5B BW 2R9 L Z 1 0 L  
 Product ID Structure Dimension Features Impedance Performance Category Numbers of Circuit Other Packaging  
 (L×W) Characteristics L:Taping(φ 180mm/reel)  
 K:Taping(φ 330mm/reel)

### 3.Rating

- Operating Temperature Range.  
 (Ambient temperature; Self-temperature rise is not included) -40°C to +105°C  
 (Product temperature; Self-temperature rise is included) -40°C to +125°C
- Storage Temperature Range. -40 to +105°C

Customer Part Number	MURATA Part Number	Impedance		DC Resistance (Ω)	*1 Rated Current(mA)		ESD 5A: 8kV
		(Ω)	Tolerance (%)		*2 Ambient temperature 85°C	*3 Ambient temperature 105°C	
	NFZ5BBW2R9LZ10L	2.9	±30	0.012±20%	4000	2050	5A
	NFZ5BBW2R9LZ10K						
	NFZ5BBW4R5LZ10L	4.5	±30	0.015±20%	3400	1800	
	NFZ5BBW4R5LZ10K						
	NFZ5BBW6R7LZ10L	6.7	±30	0.019±20%	3100	1680	
	NFZ5BBW6R7LZ10K						
	NFZ5BBW7R6LZ10L	7.6	±30	0.019±20%	3100	1680	
	NFZ5BBW7R6LZ10K						
	NFZ5BBW100LZ10L	10	±30	0.024±20%	3000	1630	
	NFZ5BBW100LZ10K						
	NFZ5BBW140LZ10L	14	±30	0.030±20%	2600	1370	
	NFZ5BBW140LZ10K						
	NFZ5BBW170LZ10L	17	±30	0.035±20%	2500	1230	
	NFZ5BBW170LZ10K						
	NFZ5BBW220LZ10L	22	±30	0.044±20%	2300	1210	
	NFZ5BBW220LZ10K						
	NFZ5BBW310LZ10L	31	±30	0.058±20%	2000	1090	
	NFZ5BBW310LZ10K						
	NFZ5BBW450LZ10L	45	±30	0.083±20%	1650	1020	
	NFZ5BBW450LZ10K						
	NFZ5BBW520LZ10L	52	±30	0.100±20%	1610	1010	
	NFZ5BBW520LZ10K						
	NFZ5BBW610LZ10L	61	±30	0.106±20%	1600	1000	
	NFZ5BBW610LZ10K						
	NFZ5BBW970LZ10L	97	±30	0.187±20%	1200	700	
	NFZ5BBW970LZ10K						
	NFZ5BBW141LZ10L	140	±30	0.259±20%	1050	600	
	NFZ5BBW141LZ10K						

\*1: As for the rated current, rated current derated as figure.1 depending on the operating temperature.

\*2: When applied rated current to the Products, temperature rise caused by self heating will be 40°C or less.

\*3: When applied rated current to the Products, temperature rise caused by self heating will be 20°C or less.

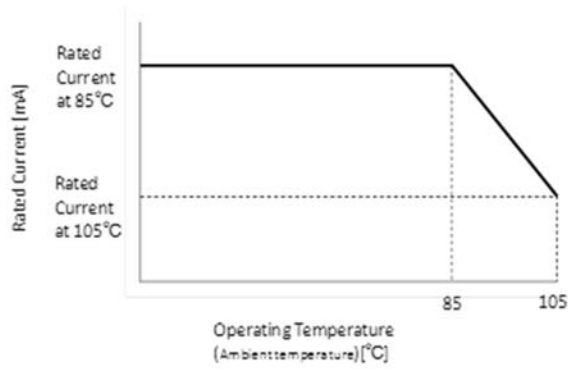

#### 4. Testing Conditions

《Unless otherwise specified》

Temperature : Ordinary Temperature / 15°C to 35°C

Humidity : Ordinary Humidity / 25%(RH) to 85%(RH)

《In case of doubt》

Temperature : 20°C ± 2°C

Humidity : 60%(RH) to 70%(RH)

Atmospheric Pressure : 86kPa to 106 kPa

#### 5. Appearance and Dimensions

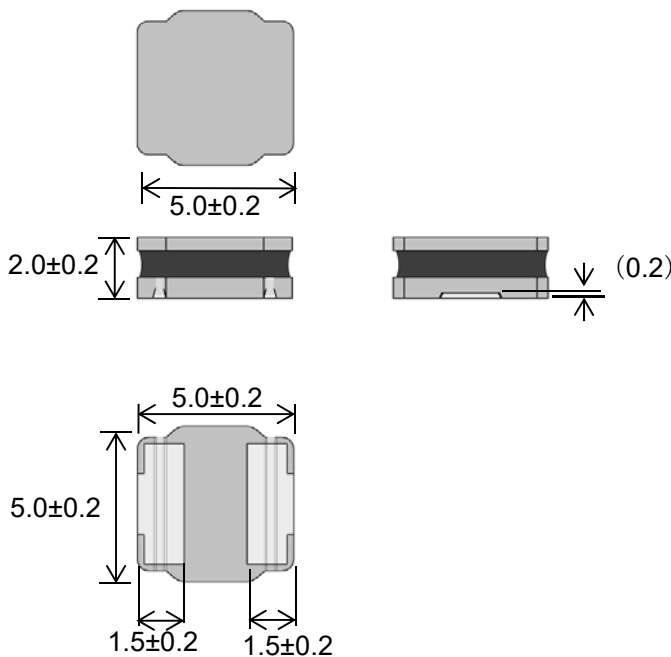

※No Marking.

■ Unit Mass (Typical value)  
0.22 g

(in mm)

#### 6. Electrical Performance

No.	Item	Specification	Test Method
6.1	Impedance	Inductance shall meet item 3.	Measuring Equipment :KEYSIGHT4284A or equivalent Measuring Frequency: 1MHz
6.2	DC Resistance	DC Resistance shall meet item 3.	Measuring Equipment:Digital multi meter

# Reference Only

Spec No. JENF243J-9103B-01

P.3/10

## 7. AEC-Q200 Requirement

### 7.1 Performance (based on Table 5 for Magnetics(Inductors / Transformer)

AEC-Q200 Rev.D issued June. 1 2010

AEC-Q200			Murata Specification / Deviation						
No	Stress	Test Method							
3	High Temperature Exposure	1000hours at 105 °C Set for 24hours at room temperature, then measured.	Meet Table A after testing.  <u>Table A</u> <table border="1" style="margin-left: auto; margin-right: auto;"> <tr> <td>Appearance</td> <td>No damage</td> </tr> <tr> <td>Impedance at 1MHz</td> <td>Within ±10%</td> </tr> <tr> <td>DC Resistance</td> <td>Within ±10%</td> </tr> </table>	Appearance	No damage	Impedance at 1MHz	Within ±10%	DC Resistance	Within ±10%
Appearance	No damage								
Impedance at 1MHz	Within ±10%								
DC Resistance	Within ±10%								
4	Temperature Cycling	1000cycles -40 °C to + 105 °C Set for 24hours at room temperature, then measured.	Meet Table A after testing.						
7	Biased Humidity	1000hours at 85 °C, 85%RH unpowered.	Meet Table A after testing.						
8	Operational Life	Apply 85 °C 1000 hours Set for 24hours at room temperature, then measured	Meet Table A after testing.						
9	External Visual	Visual inspection	No abnormalities						
10	Physical Dimension	Meet ITEM 5 (Style and Dimensions)	No defects						
12	Resistance to Solvents	Per MIL-STD-202 Method 215	Not Applicable						
13	Mechanical Shock	Per MIL-STD-202 Method 213 Condition C: 100g's/6ms/Half sine	Meet Table A after testing.						
14	Vibration	5g's for 20 minutes, 12cycles eah of 3 orientations Test from 10-2000Hz. 12cycles each of 3 orientations	Meet Table A after testing.						
15	Resistance to Soldering Heat	No-heating Solder temperature 260C+/-5 °C Immersion time 10s	Pre-heating: 150 to 180C /90±30s Meet Table A after testing.						
17	ESD	Per AEC-Q200-002	ESD Rank: Refer to Item 3. Rating. No defects						
18	Solderbility	Per J-STD-002	Method b : Not Applicable 90% of the terminations is to be soldered. (Except exposed wire)						
19	Electrical Characterization	Measured : Inductance	No defects						
20	Flammability	Per UL-94	Not Applicable						
21	Board Flex	Epoxy-PCB(1.6mm) Deflection 2mm(min) 60s minimum holding time	Meet Table A after testing. Murata deviation request: 5s						
22	Terminal Strength	Per AEC-Q200-006 A force of 17.7N for 60s	No defect						

## 8. Specification of Packaging

### 8.1 Appearance and Dimensions of plastic tape

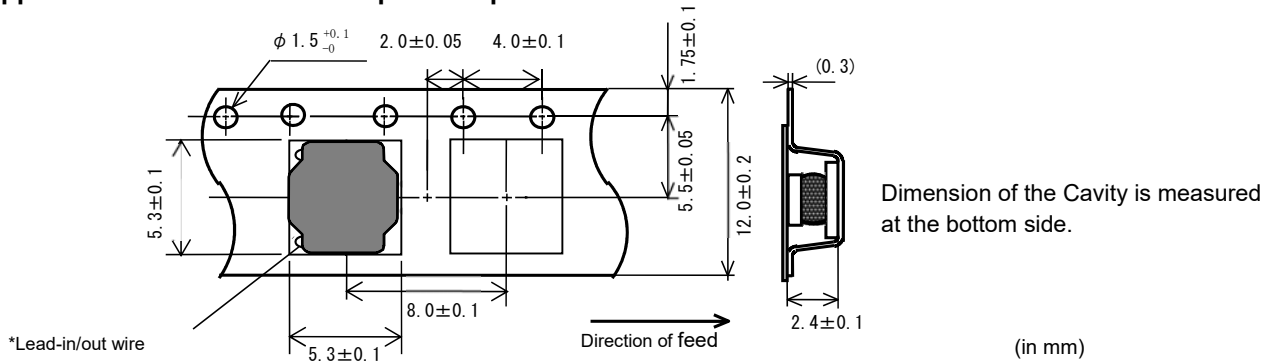

### 8.2 Specification of Taping

- (1) Packing quantity (standard quantity)
  - φ 180 mm reel : 500 pcs. / reel
  - φ 330 mm reel : 3000 pcs. / reel
- (2) Packing Method
 

Products shall be packed in the each embossed cavity of plastic tape and sealed by cover tape.
- (3) Sprocket hole
 

The sprocket holes are to the right as the tape is pulled toward the user.
- (4) Spliced point
 

Plastic tape and Cover tape has no spliced point.
- (5) Missing components number
 

Missing components number within 0.1 % of the number per reel or 1 pc., whichever is greater, and are not continuous. The specified quantity per reel is kept.

### 8.3 Pull Strength

Embossed carrier tape	10N min.
Cover tape	5N min.

### 8.4 Peeling off force of cover tape

Speed of Peeling off	300mm/min
Peeling off force	0.2 to 0.7N (minimum value is typical)

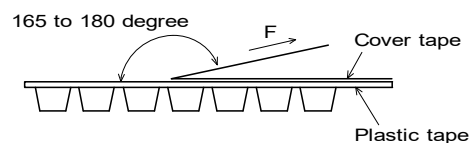

### 8.5 Dimensions of Leader-tape, Trailer and Reel

There shall be leader-tape (cover tape) and trailer-tape (empty tape) as follows.

« Packaging Code : L (φ 180mm reel) »

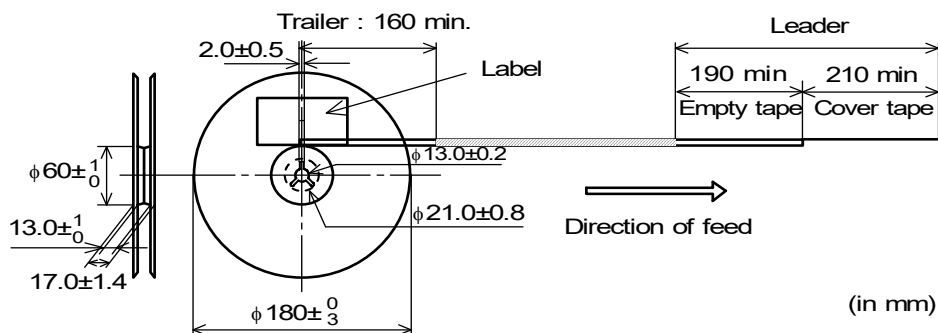

« Packaging Code : K (  $\phi$  330mm reel ) »

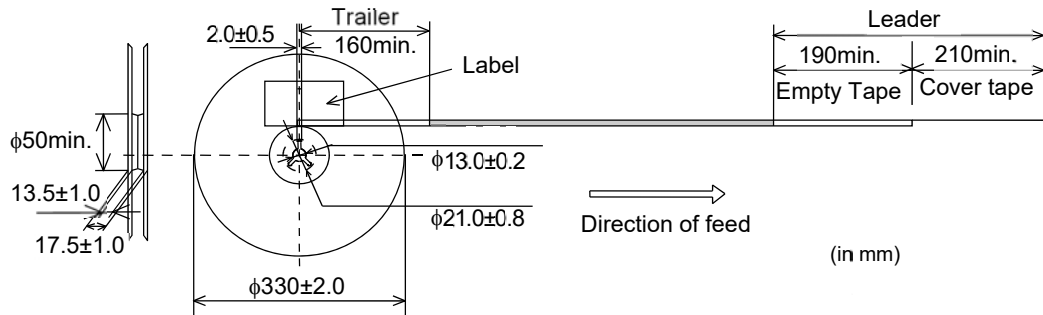

### 8.6 Marking for reel

Customer part number, MURATA part number, Inspection number(\*1), RoHS marking(\*2), Quantity etc ...

\*1) <Expression of Inspection No.>

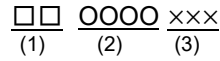

- (1) Factory Code
- (2) Date

First digit : Year / Last digit of year  
 Second digit : Month / Jan. to Sep. → 1 to 9, Oct. to Dec. → O, N, D  
 Third, Fourth digit : Day

- (3) Serial No.

\*2) « Expression of RoHS marking » ROHS – Y (  $\Delta$  )  
 (1) (2)

- (1) RoHS regulation conformity parts.
- (2) MURATA classification number

### 8.7 Marking for Outside package (corrugated paper box)

Customer name, Purchasing order number, Customer part number, MURATA part number, RoHS marking (\*2), Quantity, etc ...

### 8.8 Specification of Outer Case

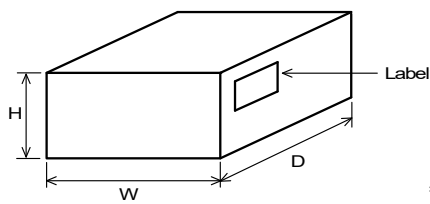

Reel	Outer Case Dimensions (mm)			Standard Reel Quantity in Outer Case (Reel)
	W	D	H	
$\phi$ 180mm	186	186	93	4
$\phi$ 330mm	340	340	95	4

\* Above Outer Case size is typical. It depends on a quantity of an order.

## 9. Caution

### 9.1 Limitation of Applications

Please contact us before using our products for the applications listed below which require especially high reliability for the prevention of defects which might directly cause damage to the third party's life, body or property.

- |                                   |  |
|-----------------------------------|--|
| (1) Aircraft equipment            | (6) Transportation equipment (vehicles, trains, ships, etc.)   |
| (2) Aerospace equipment           | (7) Traffic signal equipment   |
| (3) Undersea equipment            | (8) Disaster prevention / crime prevention equipment   |
| (4) Power plant control equipment | (9) Data-processing equipment  |
| (5) Medical equipment             | (10) Applications of similar complexity and /or reliability requirements to the applications listed in the above |

### 9.2 Caution(Rating)

Do not exceed maximum rated current of the product. Thermal stress may be transmitted to the product and short/open circuit of the product or falling off the product may be occurred.

### 9.3 Fail-safe

Be sure to provide an appropriate fail-safe function on your product to prevent a second damage that may be caused by the abnormal function or the failure of our product.

## 10. Notice

This product is designed for solder mounting.

Please consult us in advance for applying other mounting method such as conductive adhesive.

### 10.1 Land pattern designing (Reflow Soldering)

Recommended land patterns for reflow soldering are as follows:

These have been designed for Electric characteristics and solderability.

Please follow the recommended patterns. Otherwise, their performance which includes electrical performance or solderability may be affected, or result to "position shift" in soldering process.

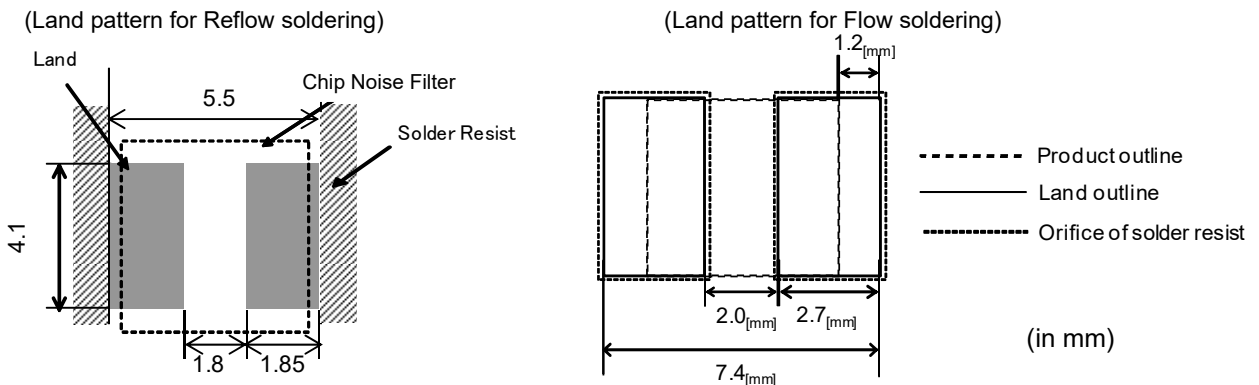

### 10.2 Flux, Solder

Flux	<ul style="list-style-type: none"> <li>• Use rosin-based flux.</li> <li>• Don't use highly acidic flux with halide content exceeding 0.2(wt)% (chlorine conversion value).</li> <li>• Don't use water-soluble flux.</li> </ul>
Solder	<ul style="list-style-type: none"> <li>• Use Sn-3.0Ag-0.5Cu solder.</li> <li>• Standard thickness of solder paste : 100 μ m to 150 μ m</li> </ul>

### 10.3 Flow soldering conditions / Reflow soldering conditions

- Pre-heating should be in such a way that the temperature difference between solder and product surface is limited to 100°C max. Cooling into solvent after soldering also should be in such a way that the temperature difference is limited to 100°C max. Insufficient pre-heating may cause cracks on the product, resulting in the deterioration of product quality.
- Standard soldering profile and the limit soldering profile is as follows. The excessive limit soldering conditions may cause leaching of the electrode and / or resulting in the deterioration of product quality.

# Reference Only

Spec No. JENF243J-9103B-01

P.7/10

## (1) Flow soldering profile

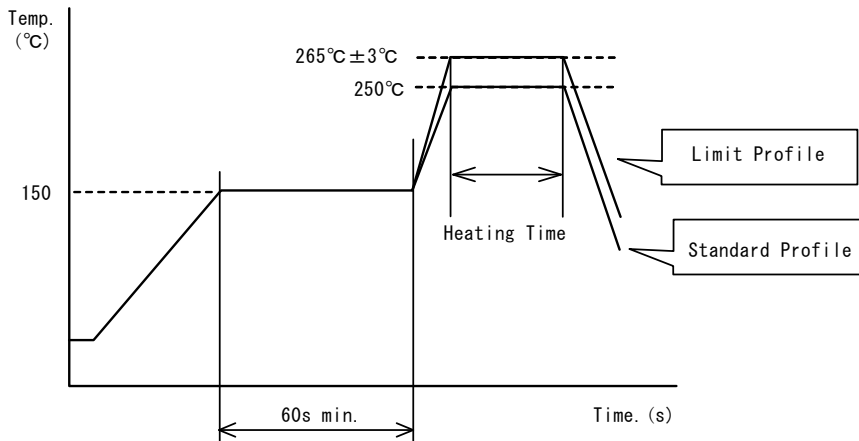

	Standard Profile	Limit Profile
Pre-heating	150°C, 60s min.	
Heating	250°C, 4s~6s	265°C±3°C, 5s
Cycle of flow	2 times	1 time

## (2) Reflow soldering profile

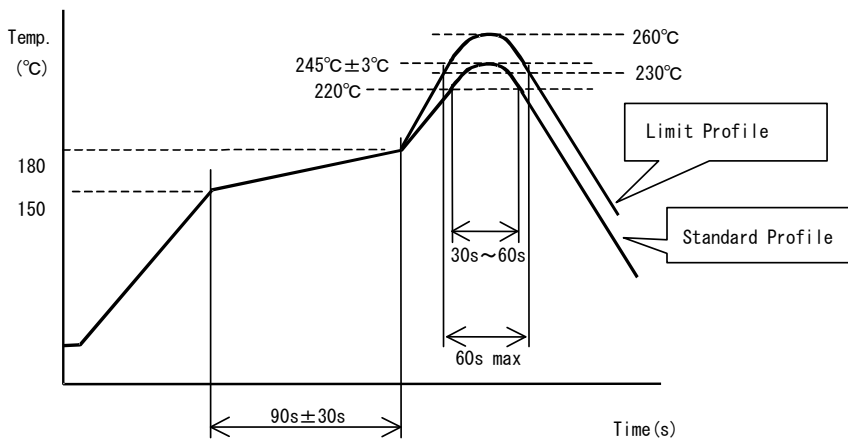

	Standard Profile	Limit Profile
Pre-heating	150~180°C, 90s±30s	
Heating	above 220°C, 30s~60s	above 230°C, 60s max.
Peak temperature	245±3°C	260°C, 10s
Cycle of reflow	2 times	2 times

### 10.4 Reworking with soldering iron.

The following conditions must be strictly followed when using a soldering iron.

Pre-heating	150°C, 1 min
Tip temperature	380°C max.
Soldering iron output	80W max.
Tip diameter	φ 3mm max.
Soldering time	3(+1,-0)s
Times	2 times

Note : Do not directly touch the products with the tip of the soldering iron in order to prevent the crack on the products due to the thermal shock.

### 10.5 Solder Volume

- Adhesive application of flow is recommended the 3-point application. (prevent the drop of products)

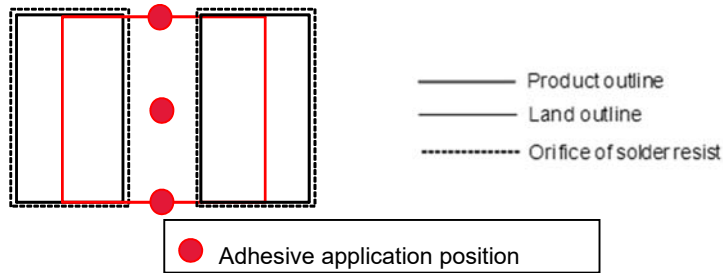

- Amount of adhesive applied is a standard 1/2 to 2/3 of the bottom flange thickness.

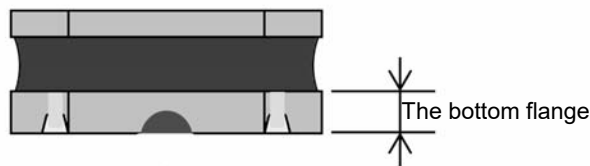

### 10.6 Product's location

The following shall be considered when designing and laying out P.C.B.'s.

- P.C.B. shall be designed so that products are not subject to the mechanical stress due to warping the board.

[Products direction]

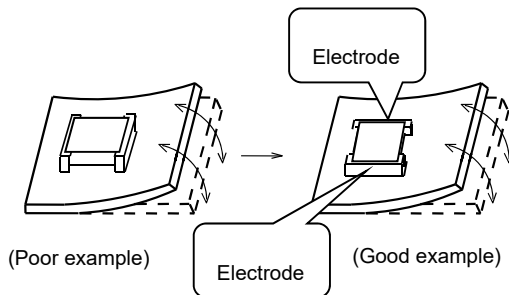

Products shall be located in the sideways direction (Length:  $a < b$ ) to the mechanical stress.

- Components location on P.C.B. separation.

It is effective to implement the following measures, to reduce stress in separating the board.

It is best to implement all of the following three measures; however, implement as many measures as possible to reduce stress.

Contents of Measures	Stress Level
(1) Turn the mounting direction of the component parallel to the board separation surface.	$A > D * 1$
(2) Add slits in the board separation part.	$A > B$
(3) Keep the mounting position of the component away from the board separation surface.	$A > C$

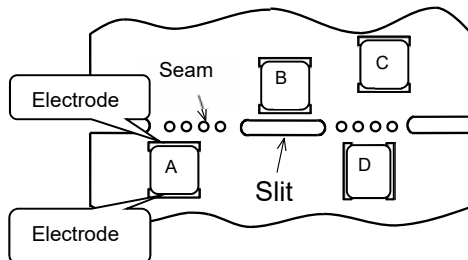

\*1  $A > D$  is valid when stress is added vertically to the perforation as with Hand Separation. If a Cutting Disc is used, stress will be diagonal to the PCB, therefore  $A > D$  is invalid.

- Mounting Components Near Screw Holes

When a component is mounted near a screw hole, it may be affected by the board deflection that occurs during the tightening of the screw. Mount the component in a position as far away from the screw holes as possible.

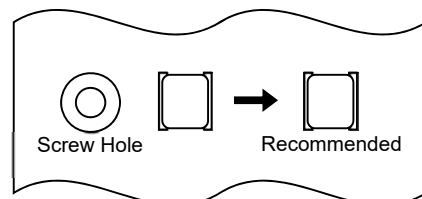



## 10.7 Cleaning Conditions

Products shall be cleaned on the following conditions.

- (1) Cleaning temperature shall be limited to 60°C max.(40°C max for IPA.)
- (2) Ultrasonic cleaning shall comply with the following conditions with avoiding the resonance phenomenon at the mounted products and P.C.B.  
Power : 20 W / l max.      Frequency : 28kHz to 40kHz      Time : 5 minutes max.
- (3) Cleaner
  1. Alternative cleaner
    - Isopropyl alcohol (IPA)
  2. Aqueous agent
    - PINE ALPHA ST-100S
- (4) There shall be no residual flux and residual cleaner after cleaning.  
In the case of using aqueous agent, products shall be dried completely after rinse with de-ionized water in order to remove the cleaner.
- (5) Other cleaning  
Please contact us.

## 10.8 Resin coating

The inductance value may change due to high cure-stress of resin to be used for coating/molding products. An open circuit issue may occur by mechanical stress caused by the resin, amount/cured shape of resin, or operating condition etc. Some resin contains some impurities or chloride possible to generate chlorine by hydrolysis under some operating condition may cause corrosion of wire of coil, leading to open circuit. So, please pay your careful attention when you select resin in case of coating/molding the products with the resin. Prior to use the coating resin, please make sure no reliability issue is observed by evaluating products mounted on your board.

## 10.9 Caution for use

- Sharp material such as a pair of tweezers or other material such as bristles of cleaning brush, shall not be touched to the winding portion to prevent the breaking of wire.
- Mechanical shock should not be applied to the products mounted on the board to prevent the breaking of the core.

## 10.10 Handling of a substrate

After mounting products on a substrate, do not apply any stress to the product caused by bending or twisting to the substrate when cropping the substrate, inserting and removing a connector from the substrate or tightening screw to the substrate.

Excessive mechanical stress may cause cracking in the product.

Bending

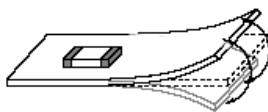

Twisting

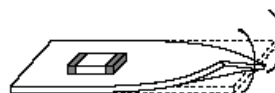

## 10.11 Storage and Handling Requirements

- (1) Storage period  
Use the products within 12 months after delivered.  
Solderability should be checked if this period is exceeded.
- (2) Storage conditions
  - Products should be stored in the warehouse on the following conditions.  
Temperature : -10 ~ 40°C  
Humidity : 15 to 85% relative humidity    No rapid change on temperature and humidity  
The electrode of the products is coated with solder. Don't keep products in corrosive gases such as sulfur, chlorine gas or acid, or it may cause oxidization of electrode, resulting in poor solderability.
  - Products should not be stored on bulk packaging condition to prevent the chipping of the core and the breaking of winding wire caused by the collision between the products.
  - Products should be stored on the palette for the prevention of the influence from humidity, dust and so on.
  - Products should be stored in the warehouse without heat shock, vibration, direct sunlight and so on.
- (3) Handling Condition  
Care should be taken when transporting or handling product to avoid excessive vibration or mechanical shock.