

NL-AB-MPCIE2 Datasheet

NimbeLink Corp

Updated: February 2021



© NimbeLink Corp. 2021. All rights reserved.

NimbeLink Corp. provides this documentation in support of its products for the internal use of its current and prospective customers. The publication of this document does not create any other right or license in any party to use any content contained in or referred to in this document and any modification or redistribution of this document is not permitted.

While efforts are made to ensure accuracy, typographical and other errors may exist in this document. NimbeLink reserves the right to modify or discontinue its products and to modify this and any other product documentation at any time.

All NimbeLink products are sold subject to its published Terms and Conditions, subject to any separate terms agreed with its customers. No warranty of any type is extended by publication of this documentation, including, but not limited to, implied warranties of merchantability, fitness for a particular purpose and non-infringement.

NimbeLink is a registered trademark, and Skywire is a registered trademark, of NimbeLink Corp. All trademarks, service marks and similar designations referenced in this document are the property of their respective owners.

Table of Contents

Table of Contents	2
Introduction	3
Contact Information	3
Orderable Part Numbers	3
Additional Resources	3
Technical Specifications	4
Block Diagram	4
Electrical Specifications	4
Absolute Maximum and Minimum Ratings	4
mPCIe Interface Pinout	5
Power Supply	5
Skywire Modem Socket Pinout	6
Mechanical Characteristics	7
Mechanical Drawing	7
Mechanical Specifications	7
Mating Connectors	7
Device Placement	8
Environmental Specifications	8
Modem Operation	9
USB Communication	9
Control Signals	9
PERST#	9
W_DISABLE#	9
WAKE#	9
LED_WWAN#	10
Modem Power On and Off	10
Power On	10
Power Off	10
Version Information	11

1. Introduction

This document serves as the hardware datasheet for the Skywire mPCIe Version 2 adapter card.

The Skywire mPCIe Version 2 adapter card is a compact, mPCIe compatible adapter for the Skywire modem. The adapter allows the easy addition of Skywire modems to Machine to Machine (M2M) systems with a mPCIe interface. This adapter is compatible with all Skywire modems using the standard Skywire interface.

1.1 Contact Information

NimbeLink's goal is to make integrating Skywire modems into end-user applications as easy as possible. Please send any feedback, documentation requests, or technical support questions to NimbeLink's product support team at:

product.support@nimbelink.com

For purchasing information, please visit the "Part Ordering Information" section on the adapter's product page. Any additional sales questions or requests for quotation can be directed to NimbeLink's sales team at:

sales@nimbelink.com

1.2 Orderable Part Numbers

Orderable Device	mPCIe Form Factor	Operating Temperature
NL-AB-MPCIE2-H	Half Size*	-40°C to +85°C

*To accommodate the Skywire footprint the half size mPCIe adapter's mechanical footprint is larger than a standard half size mPCIe card. See mechanical drawing for details.

1.3 Additional Resources

- [Skywire Software Developers Guide](#)
- [NL-AB-MPCIE2 Product Page](#)
- [NL-AB-MPCIE2-H Altium Design Files](#)
- [NL-AB-MPCIE2-H Schematic](#)

2. Technical Specifications

2.1 Block Diagram

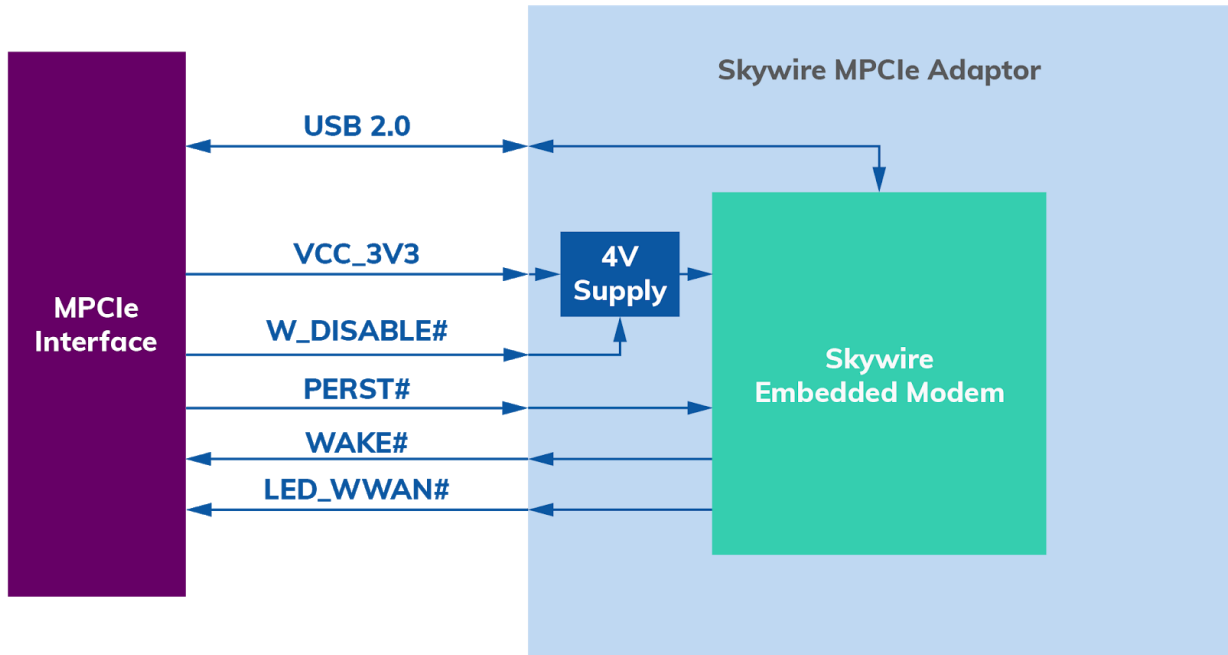

2.2 Electrical Specifications

2.2.1 Absolute Maximum and Minimum Ratings

To avoid potential damage to the modem, ensure that all voltages applied to the mPCIe card pins listed below do not fall outside of the ranges specified by the maximum and minimum ratings:

Parameter	Skywire Pin(s)	Min. Rating	Max. Raing
Main Power Supply ¹	VCC_3V3	2.9V	3.6V
mPCIe I/O Referenced Signals	LED_WWAN#, PERST#, WAKE#, W_DISABLE#	-0.3 V	3.6V

1. Transient voltage drooping can occur on the VCC rail during normal modem operation. In order to prevent damage to the modem, transient voltage drops on VCC_3V3 must not fall below 2.9V.

2.2.2 mPCIe Interface Pinout

Pin	Name	Direction	Description	Min	Typ.	Max
1	WAKE#	Output	Wake Host	0V	3.3V	3.6V
20	W_DISABLE#	Input	Modem Disable	0V	3.3V	3.6V
22	PERST#	Input	Modem Reset	0V	3.3V	3.6V
36	USB_D-	I/O	USB D-			
38	USB_D+	I/O	USB +			
42	LED#	Output	WWAN LED Drive	0V	3.3V	3.6V
24, 39, 41, 52	VCC_3V3	Power	3.3V Power Supply	2.9V	3.3V	3.6V
4, 9, 15, 18, 21, 26, 27, 29, 34, 35, 37, 40, 43, 50	Ground	Ground	Ground		0V	
2, 3, 5, 6, 7, 8, 10-14, 16, 17, 19, 23, 24, 25, 28, 30-33, 44-49, 51	NC		No Connect		-	

2.3 Power Supply

Cellular modems will rapidly consume large amounts of current during network transactions. The external power supply connected to pins 24, 39, 41, and 52 must be able to handle current transients up to 2.5A (at 3.3V). Additional capacitance (100's uF) may be required to be placed near the mPCIe card connector to ensure VCC_3V3 voltage stability.

System designers must ensure that the voltage into the adapter's power pins never exceed the bounds of the power supply operating voltage range during modem operation.

The power consumption of the adapter will vary depending on which modem is being used. Please refer to the datasheet for the modem being used with the adapter for power consumption estimates.

Power Supply Requirements	
Nominal Supply Voltage	3.3V
Supply Voltage Range	2.9V-3.6V
Max Ripple on Supply Voltage	30mV
Max Current Transients	2.5A*

*Current transients will vary by modem, technology used, and from host supply configuration.

2.3.1 Skywire Modem Socket Pinout

The following table details the pinout of the Skywire modem socket on the mPCIe adapter.

Pin	Name	Direction	Description	Min	Typ.	Max
1 (J1-1)	VCC	Input	Main Power Supply Pin		4.0V	
2 (J1-2)	DOUT	NC	Not Connected		-	
3 (J1-3)	DIN	NC	Not Connected		-	
4 (J1-4)	GND	Input	Ground Pin		0V	
5 (J1-5)	nRESET	Input	Modem reset signal. Controlled by mPCIe PERST#	0V		1.8V
6 (J1-6)	VUSB	Input	USB connection detection		5.0V	
7 (J1-7)	USB_P	I/O	USB differential data bus (+)		-	
8 (J1-8)	USB_N	I/O	USB differential data bus (-)		-	
9 (J1-9)	DTR	Input	Data terminal ready. Tied low.		0V	
10 (J1-10)	GND	Input	Ground Pin		0V	
11 (J2-1)	GND	Input	Ground Pin		0V	
12 (J2-2)	CTS	NC	Not Connected			
13 (J2-3)	ON/nSLEEP	Output	Modem status pin. Controls mPCIe LED_WWAN#	0V		1.8V
14 (J2-4)	VREF	Input	Voltage reference for offboard I/O signals.		4.0V	
15 (J2-5)	GND	Input	Ground Pin		0V	
16 (J2-6)	RTS	Input	Pulled Low.		0V	
17 (J2-7)	GPIO_3	I/O	Modem GPIO pin. Not Connected.	0V		1.8V
18 (J2-8)	GPIO_2	I/O	Modem GPIO pin. Controls mPCIe WAKE#	0V		1.8V
19 (J2-9)	RING	NC	Not Connected.		-	
20 (J2-10)	ON_OFF	Input	Modem ON_OFF Control. Driven by U3.	0V		1.8V

2.4 Mechanical Characteristics

2.4.1 Mechanical Drawing

To be released.

2.4.2 Mechanical Specifications

Parameter	Typical	Unit
Dimensions	33.4 x 30.0 x 5.4	mm
Weight		Grams
Connector Insertion/Removal	10	Cycles

2.4.3 Mating Connectors

The mPCIe adapter is designed to be used in a 52 pin mPCIe socket. Example sockets that could be used with the card are listed below.

Manufacturer	Part Number
TE Connectivity AMP Connectors	2041262-1
JAE Electronics	MM60-52B1-B1-R850

2.4.4 Device Placement

⚠ Make sure the Skywire is installed in the correct orientation in your host board. Failure to do so will damage the device and void the warranty.

To seat the modem, align the Skywire modem's u.FI connectors with the two circles seen on the top of the mPCIe adapter. When viewing the mPCIe adapter from the top, the modem's u.FI connectors should be on the left side of the adapter when mounted. An example rendering of the placement is below.

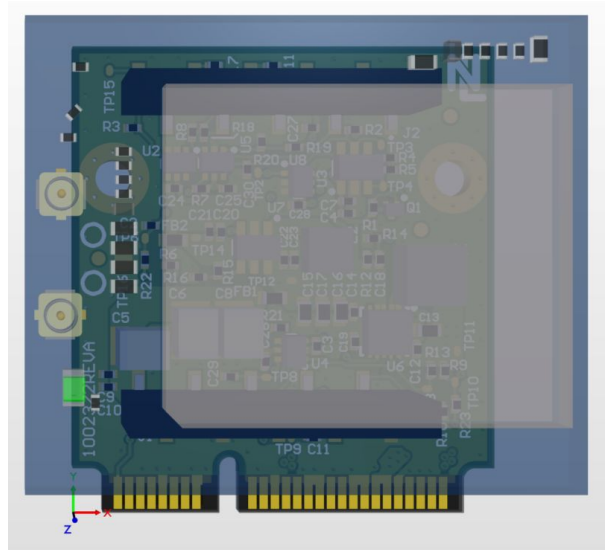

2.4.5 Environmental Specifications

Parameter	Min	Typical	Max	Unit	Note
Operating Temperature	-40	+25	+85	°C	
Storage Temperature	-40	+25	+85	°C	
Operating Humidity	20		90	%	Non-condensing

3. Modem Operation

The following section details how the mPCIe adapter interfaces with the modem and documents the mPCIe control signal operation.

3.1 USB Communication

The mPCIe adapter connects to the modem's USB 2.0 interface. The modem's Serial UART interface is not available for use with the mPCIe adapter.

3.2 Control Signals

The mPCIe adapter provides four mPCIe control signals for controlling the Skywire modem as described in the following sections. The mPCIe adapter control signals are pre-configured using pull up resistors to allow the modem to immediately boot when power is applied.

3.2.1 PERST#

The PERST# signal is an active low signal used to force a hardware reset of the cellular modem. The PERST# signal should only be used as a last resort when the modem is no longer responding to commands.

When PERST# is asserted it will also trigger the ON_OFF pin controller, U5, to toggle the modem's ON_OFF pin to boot the modem back up.

The PERST# is internally pulled high by the modem to allow for a proper power on sequence and does not need to be actively controlled during startup.

3.2.2 W_DISABLE#

W_DISABLE# is an active low signal used to control the 4.0V power supply for the modem. Asserting this signal will cut power to the modem. Prior to powering down the modem, users must properly power down the modem. Otherwise, they risk damaging the modem. Leave as not connected or drive high to keep the modem always on.

3.2.3 WAKE#

The WAKE# signal is used to wake the host system from stand-by. This signal is not configured by default and its use can be mapped via AT commands on the cellular modem.

The WAKE# signal is controlled by pin 17 of the Skywire modem and is referenced to VCC_3V3 by a 10 K Ω resistor.

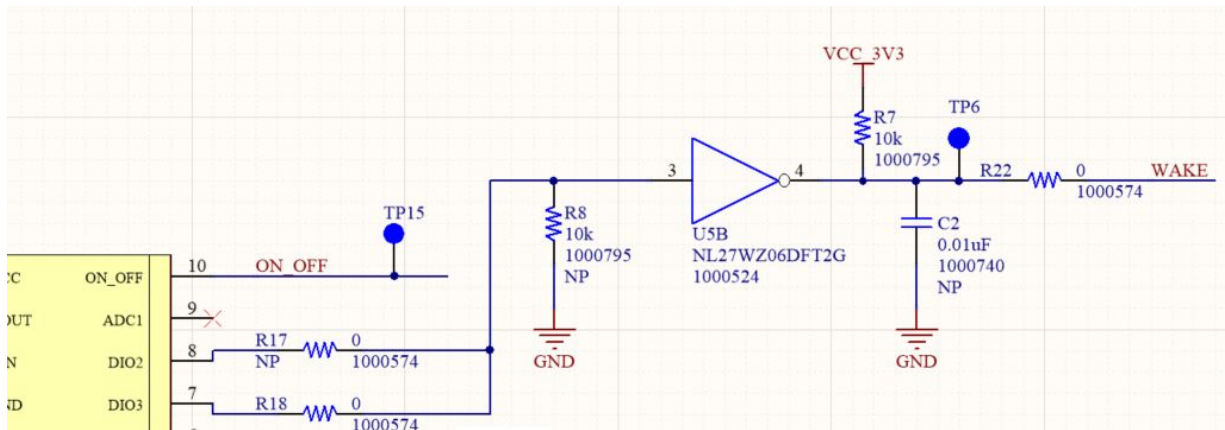

The GPIO pins on some Skywire modems may toggle while the modem is booting. If this causes an issue for the host system, the control GPIO can be changed to Skywire pin 18 by de-populating R18 and populating R17 on the adapter board.

3.2.4 LED_WWAN#

LED_WWAN# is an active low signal that is driven by default. It can be used to drive an LED on the host system.

3.3 Modem Power On and Off

3.3.1 Power On

The adapter card will automatically boot the modem when power is applied. The mPCIe adapter has a built in auto power on circuit using a TI TPL5111DDCR (U5) that will toggle the modem's ON_OFF pin low for ~7.5 seconds after the 4.0V supply is enabled. The ON_OFF signal will also be toggled when the PERST# signal is asserted.

3.3.2 Power Off

Prior to removing the system's VCC_3V3 power, the cellular modem must be properly powered down. Removing power prior to shutting down the modem violates carrier standards and may damage the modem. Please see the AT command manual of the modem being used for the proper shutdown command for the modem. Users must wait for the modem to fully de-enumerate from the host system prior to removing power.

Example Shut Down Sequence:

1. Shut down the modem via AT command.
2. Wait for the modem to de-enumerate.
3. Assert W_DISABLE#.
4. Remove VCC_3V3.