

Future Technology Devices International Limited Datasheet NerO Module



1 Introduction

The Nero is a reference design for an energy efficient Arduino UNO compatible board based on the ATMEGA328 with the FTDI FT231X USB-UART, capable of operating at 5V with a full 1A while remaining cool to the touch

There are 3 type of modules for selection:

- NerO-LP1, with 2.54mm pitch female header with long shield pins
- NerO-SP1, with 2.54mm pitch female header with short shield pins
- NerO-NP1, with spare shield pins but not mounted. (Provide long shield pins externally.)

1.1 Features

- 16MHz ATmega328 32-pin TQFP package microcontroller.
- UNO R3 form factor
- 14 Digital I/O Pins (6 PWM outputs)
- 6 Analog Inputs
- FTDI FT231XS USB UART interface
- A Micro-B USB connects to PC connect and communication.
- VIN Input voltage - 7V to 20V (9V or 12V recommended)
- Hardware Reset button provided.
- 5V Switching regulator with 1A output current
- CE and FCC certified
- [Optiboot bootloader](#) preloaded
- [Arduino Software \(IDE\)](#) and UNO library compatible,
- Arduino shield compatible
- FTDI Shield available soon

Neither the whole nor any part of the information contained in, or the product described in this manual, may be adapted or reproduced in any material or electronic form without the prior written consent of the copyright holder. This product and its documentation are supplied on an as-is basis and no warranty as to their suitability for any particular purpose is either made or implied. Future Technology Devices International Ltd will not accept any claim for damages howsoever arising as a result of use or failure of this product. Your statutory rights are not affected. This product or any variant of it is not intended for use in any medical appliance, device or system in which the failure of the product might reasonably be expected to result in personal injury. This document provides preliminary information that may be subject to change without notice. No freedom to use patents or other intellectual property rights is implied by the publication of this document. Future Technology Devices International Ltd, Unit 1, 2 Seaward Place, Centurion Business Park, Glasgow G41 1HH United Kingdom. Scotland Registered Company Number: SC136640

2 Ordering Information

Part No.	Description
NerO-LP1	Arduino UNO compatible board based on the FTDI FT231X USB UART. Power supply delivers 5V at a full 1A without overheating. Long shield pins.
NerO-SP1	Arduino UNO compatible board based on the FTDI FT231X USB UART. Power supply delivers 5V at a full 1A without overheating. Short shield pins.
NerO-NP1	Arduino UNO compatible board based on the FTDI FT231X USB UART. Power supply delivers 5V at a full 1A without overheating. Spare shield pins (not mounted and provide long shield pins on the package.)

3 Program Support

- The open-source Arduino Software (IDE) can be downloaded at Arduino website. Visit Arduino's website at <https://www.arduino.cc/en/Main/Software> for more information. [The Arduino IDE programming user guide](#) gives the instruction of software development.
- The programmer utility – In case to customize the module descriptions and other parameters, FT_Prog is provided for FT231XS by FTDI. Visit FTDI's website at <http://www.ftdichip.com/Support/Utilities.htm> for more information.

Table of Contents

1	Introduction	1
1.1	Features.....	1
2	Ordering Information	2
3	Program Support.....	3
4	Board Layout.....	5
4.1	Power Supply	6
4.2	Micro-controller	7
4.3	USB to Serial UART Converter	8
4.4	External I/O Port	8
5	Devices Characteristics and Ratings.....	11
5.1	Electrical Parameters	11
6	Board Schematic	12
7	Block Diagram.....	13
8	Mechanical Dimensions	14
8.1	NerO PCB Dimensions	14
9	Contact Information.....	15
	Appendix A - References	16
	Document References	16
	Acronyms and Abbreviations	16
	Appendix B – List of Figures and Tables.....	17
	List of Tables	17
	List of Figures	17
	Appendix C – Revision History	18

4 Board Layout

The *NerO* development board is 68.535mm X 53.3mm two-layer printed circuit board with key elements shown below:



Figure 1 - NerO Board Top View

Key Features:

1. Micro USB connector
2. Status and PWR LEDs moved to edge of PCB – and remain visible when a shield is placed on the expansion connectors.
3. On-Off Switch for added user convenience
4. FTDI FT231X USB UART bridge (Note 1)
5. 5V Switching regulator vs LDO regulator (Note 2)
6. FCC/CE certified (Note 3)

Note 1 - FT231X is one of the latest X-series family of USB UART solutions from FTDI. It has larger communication buffers at a lower cost compared to our popular ubiquitous FT232R device. FT231X has 3.3V output levels and 5V tolerant inputs. FTDI provide drivers for its USB bridge devices across many platforms including certified drivers for Windows, including Windows 10.

Note 2 -The *NerO* Buck Switcher regulator is much more energy efficient than an LDO device especially at higher Voltage inputs. It can supply a full 1A current at 5V without breaking sweat, or anything else.

Great in all circumstances where external power is used - especially for designs with higher power requirements such as driving displays/LEDs/ Wi-Fi etc. An excellent solution for 9V battery powered solutions, automotive (12V) and POE designs as well.

Note 3 - *NerO* is FCC/CE certified as is the original UNO, and so is suitable for commercial applications as well as hobbyist/maker projects

4.1 Power Supply

The *NerO* board provides alternative power supply sources with an On/Off Switch (SW1):

1. 9V or 12V DC supply, 2.1mm power DC Jack Connector **CN2**.

The 9V or 12V option is recommended in designs using the *NerO* to supply power to Arduino shields

- SW1 – On/Off Switch

Switch Mode	DC
ON	✓
OFF	×

Table 1 - Switch Mode

Once the power supply is connected and turned on, a Green LED power indicator will be turned on. When the DC supply is on, the 5V Buck regulator will also be turned on, its 5V power output will serve the module including peripherals of Atmega328P MCU and 3.3V fixed LDO. The 3.3V LDO will provide power to the FT231X USB to UART bridge device.

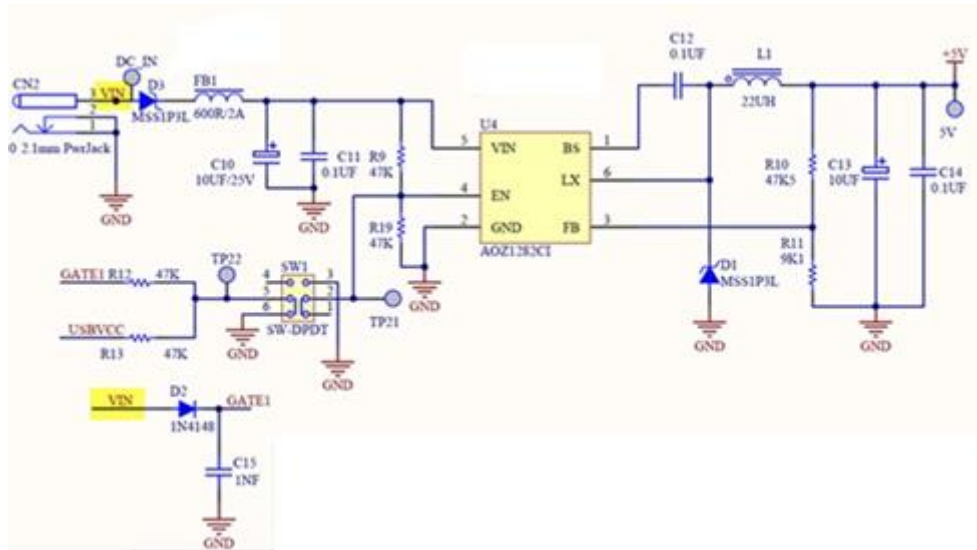

Figure 2 - DC Power Supply

When a USB cable is inserted, the design detects the USB Vbus status and blocks the back-voltage to the USB host when the USB host is in hibernate or power off.

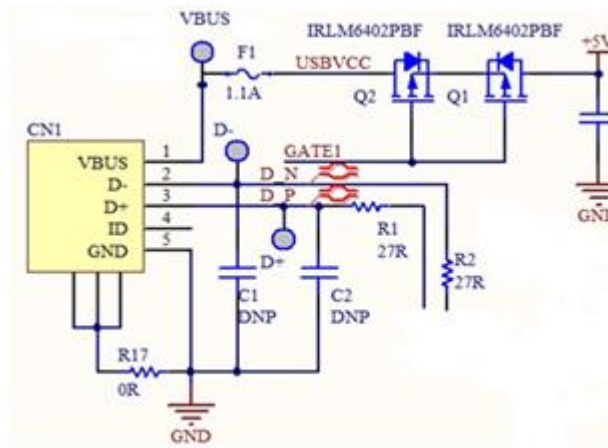

Figure 3 - USB back-voltage block circuit

4.2 Micro-controller

The on-board Arduino controller is the Atmega328P 32-pin TQFP microcontroller from ATMEL's 8-bit Microcontroller family. This microcontroller runs at 16MHZ from a 5V power supply. For further details of the Atmega328P Microcontroller, refer to the [Atmega328P datasheet](#).

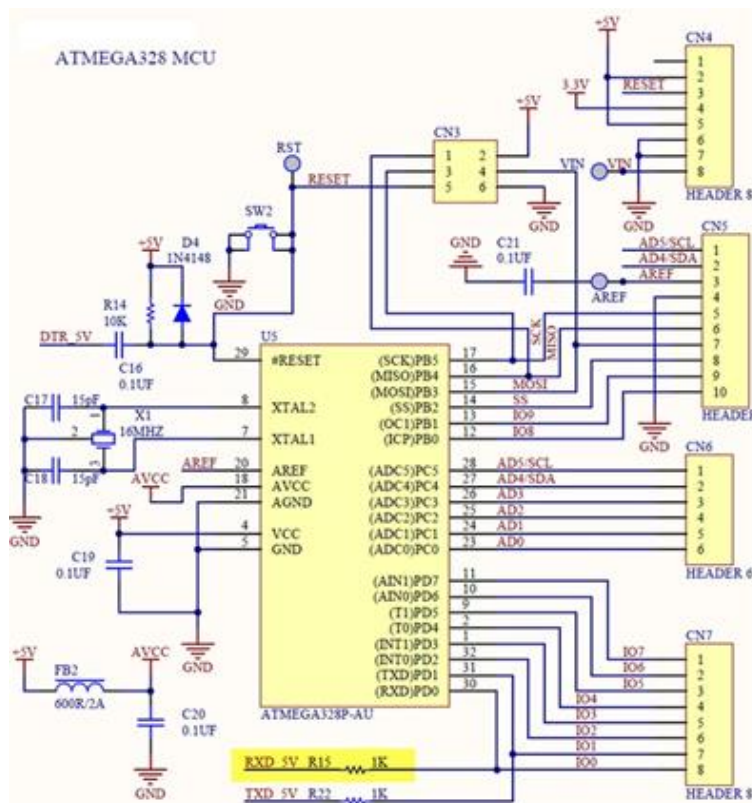

Figure 4 - Atmega328P Micro-controller

4.3 USB to Serial UART Converter

Loading firmware into the ARDUINO is done over USB via the FT231XS 20 Pin SSOP USB to serial UART converter. For detail of the FT231XS, refer to the [FT231XS datasheet](#). Two Status LED connected to the FT231XS provide visual indication of RX/TX traffic on the device UART port.

LEDs	Colour	Description
TX	Yellow	Blinking – Transmitting
RX	Yellow	Blinking – Receiving

Table 2- LED Status

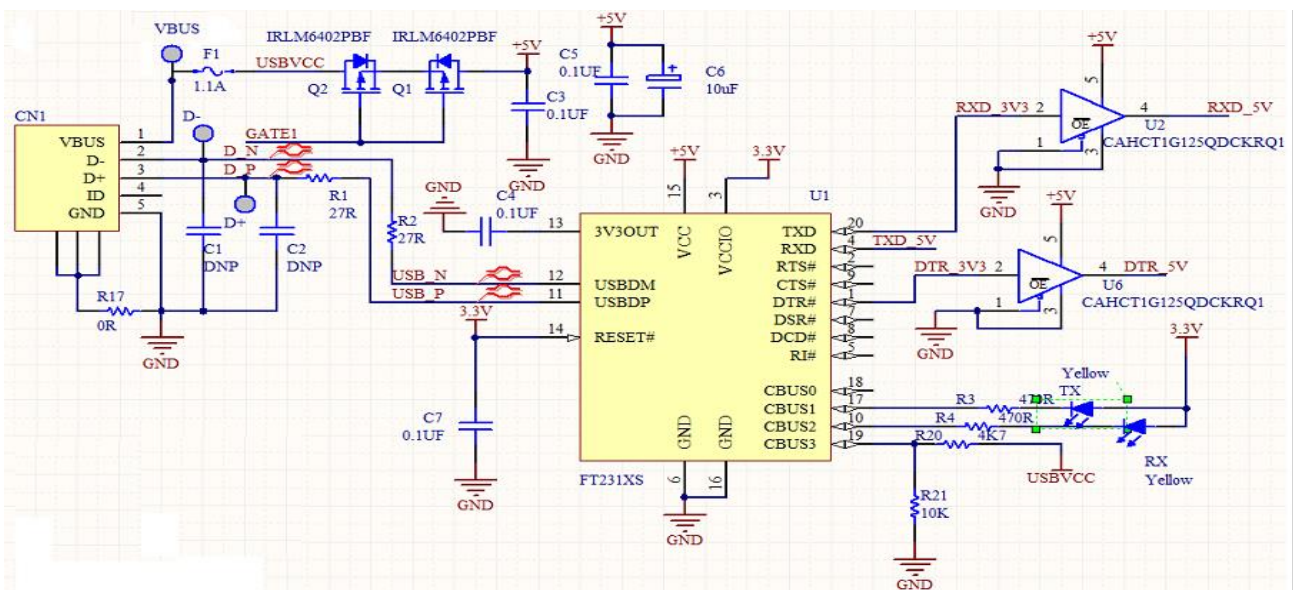

Figure 5 - FT231XS USB to Serial Converter

4.4 External I/O Port

There are 14 digital IO pins provided on **CN5**(1X 10 pins) and **CN7**(1X 8 pins), 2.54mm pitch female header.

There are 6 Analog inputs provided on **CN6**(1X 6 pins), 2.54mm female header.

CN4(1X 8 pins) 2.54mm female header provides access to supply or draw power to/from the board.

Table 3 - **Pin Mapping of CN5** lists the entire pin mapping on CN5

Pin No	Pin Name	Description
1	SCL	I ² C Serial Bus, clock line

2	SDA	I ² C Serial Bus, data line
3	AREF	Analog Reference pin for ADC
4	GND	Ground
5	13	GPIO 13
6	12	GPIO 12
7	11	GPIO 11/ PWM
8	10	GPIO 10/ PWM
9	9	GPIO 9/ PWM
10	8	GPIO 8

Table 3 - Pin Mapping of CN5

Table 4 - **Pin Mapping of CN7** lists the entire pin mapping on CN7

Pin No	Pin Name	Description
1	7	GPIO 7
2	6	GPIO 6/ PWM
3	5	GPIO 5/ PWM
4	4	GPIO 4
5	3	GPIO 3/ PWM
6	2	GPIO 2
7	1	GPIO 1
8	0	GPIO 0

Table 4 - Pin Mapping of CN7

Table 5 - **Pin Mapping of CN6** lists the entire pin mapping on CN6

Pin No	Pin Name	Description
1	A5	Analog input 5
2	A4	Analog input 4
3	A3	Analog input 3
4	A2	Analog input 2
5	A1	Analog input 1
6	A0	Analog input 0

Table 5 - Pin Mapping of CN6

Table 6 - **Pin Mapping of CN4** lists the entire pin mapping on CN4

Pin No	Pin Name	Description
--------	----------	-------------

1	-	-
2	5V	5V output
3	RST	Atmega328P Reset signal
4	3.3V	3.3V output
5	5V	5V output
6	GND	Ground
7	GND	Ground
8	VIN	DC supply input

Table 6 - Pin Mapping of CN4

5 Devices Characteristics and Ratings

5.1 Electrical Parameters

Parameter	Value	Unit	Conditions
Storage Temperature	-65°C to 150°C	Degrees C	
Ambient Operating Temperature (Power Applied)	0°C to 75°C	Degrees C	

Table 7 - Temperature Parameter

DC Characteristics (Ambient Temperature = 0°C to +75°C)

Parameter	Description	Minimum	Typical	Maximum	Units	Conditions
DC	DC power supply	6	9, 12	20	V	
Idc	Max rating 5V output rating to connector			1	A	
Vio	3.3 Vio voltage reference	3.0		3.6	V	
Ivio	Max rating total current draw from IO pin			50	mA	
Io	Max IO output current			20	mA	

Table 8 – Operating Voltage and Current

6 Board Schematic

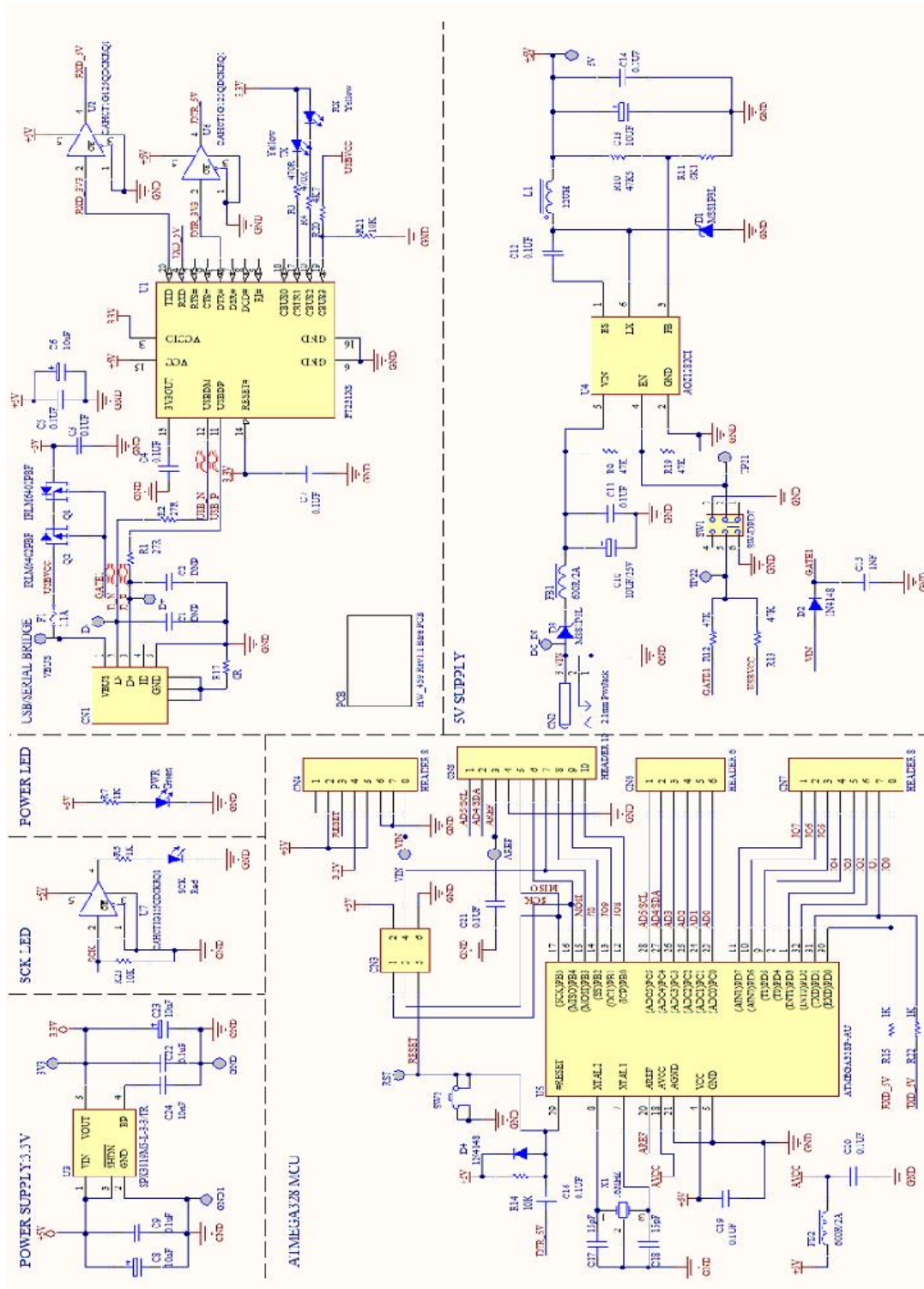

Figure 6 – NerO Schematic

7 Block Diagram

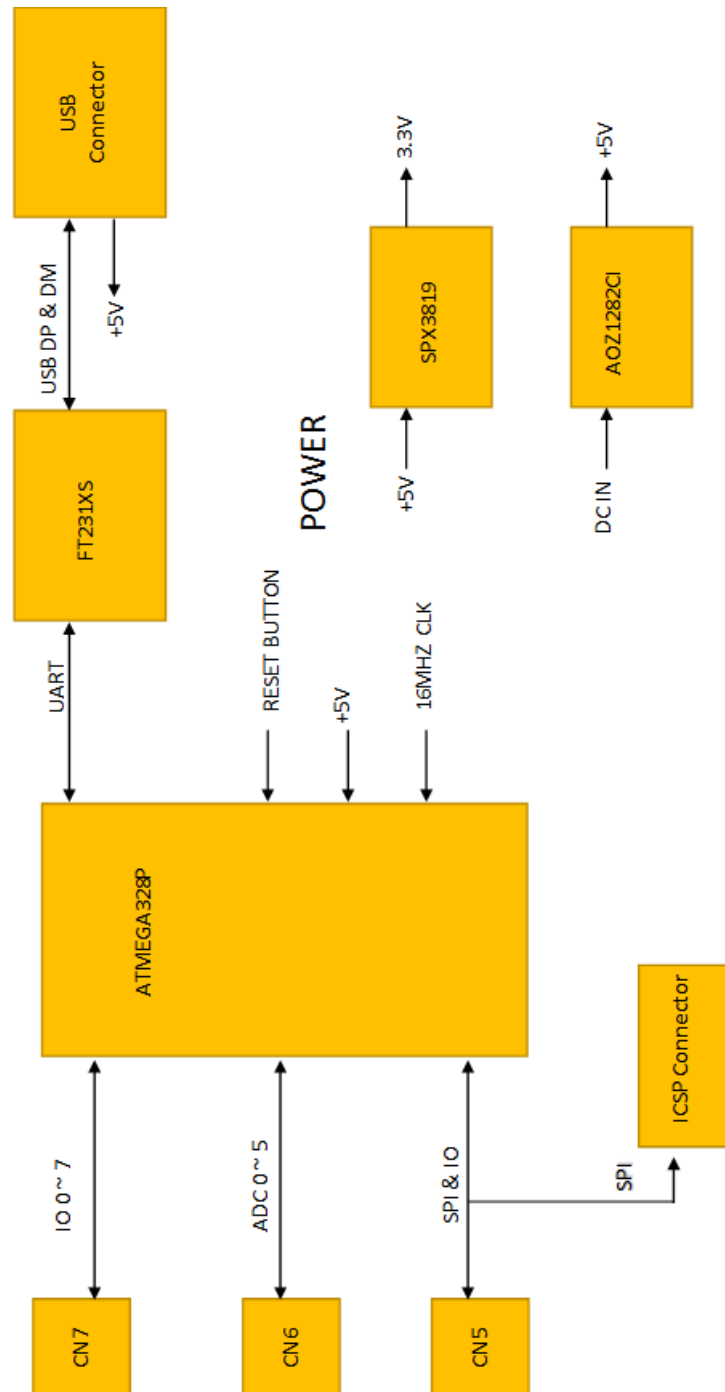

Figure 7 – NerO Board Diagram

8 Mechanical Dimensions

8.1 NerO PCB Dimensions

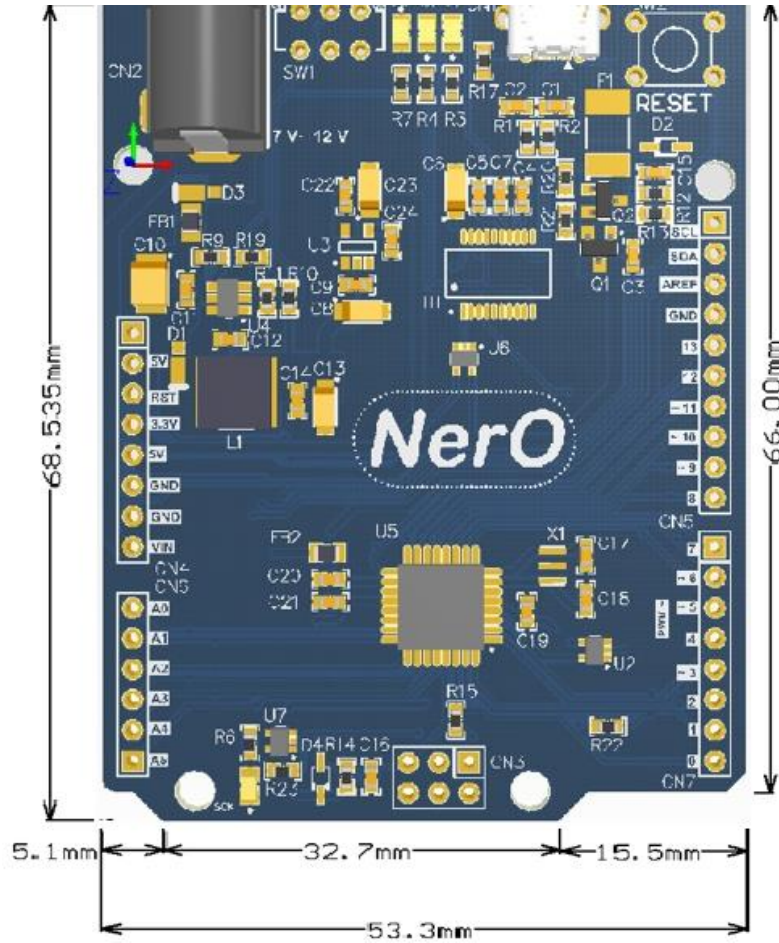

Figure 8 – NerO PCB Dimensions (Top view)



Figure 9 – NerO PCB Dimensions (Side view)

9 Contact Information

Head Quarters – Singapore

Bridgetek Pte Ltd
178 Paya Lebar Road, #07-03
Singapore 409030
Tel: +65 6547 4827
Fax: +65 6841 6071

E-mail (Sales) sales.apac@brtchip.com
E-mail (Support) support.apac@brtchip.com

Branch Office – Taipei, Taiwan

Bridgetek Pte Ltd, Taiwan Branch
2 Floor, No. 516, Sec. 1, Nei Hu Road, Nei Hu District
Taipei 114
Taiwan, R.O.C.
Tel: +886 (2) 8797 5691
Fax: +886 (2) 8751 9737

E-mail (Sales) sales.apac@brtchip.com
E-mail (Support) support.apac@brtchip.com

Branch Office - Glasgow, United Kingdom

Bridgetek Pte. Ltd.
Unit 1, 2 Seaward Place, Centurion Business Park
Glasgow G41 1HH
United Kingdom
Tel: +44 (0) 141 429 2777
Fax: +44 (0) 141 429 2758

E-mail (Sales) sales.emea@brtchip.com
E-mail (Support) support.emea@brtchip.com

Branch Office – Vietnam

Bridgetek VietNam Company Limited
Lutaco Tower Building, 5th Floor, 173A Nguyen Van
Troj,
Ward 11, Phu Nhuan District,
Ho Chi Minh City, Vietnam
Tel : 08 38453222
Fax : 08 38455222

E-mail (Sales) sales.apac@brtchip.com
E-mail (Support) support.apac@brtchip.com

Web Site

<http://brtchip.com/>

Distributor and Sales Representatives

Please visit the Sales Network page of the [Bridgetek Web site](#) for the contact details of our distributor(s) and sales representative(s) in your country.

System and equipment manufacturers and designers are responsible to ensure that their systems, and any Future Technology Devices International Ltd (FTDI) devices incorporated in their systems, meet all applicable safety, regulatory and system-level performance requirements. All application-related information in this document (including application descriptions, suggested FTDI devices and other materials) is provided for reference only. While FTDI has taken care to assure it is accurate, this information is subject to customer confirmation, and FTDI disclaims all liability for system designs and for any applications assistance provided by FTDI. Use of FTDI devices in life support and/or safety applications is entirely at the user's risk, and the user agrees to defend, indemnify and hold harmless FTDI from any and all damages, claims, suits or expense resulting from such use. This document is subject to change without notice. No freedom to use patents or other intellectual property rights is implied by the publication of this document. Neither the whole nor any part of the information contained in, or the product described in this document, may be adapted or reproduced in any material or electronic form without the prior written consent of the copyright holder. Future Technology Devices International Ltd, Unit 1, 2 Seaward Place, Centurion Business Park, Glasgow G41 1HH, United Kingdom. Scotland Registered Company Number: SC136640

Appendix A - References

Document References

For module documentations, please refer to URL below:

FT231XS datasheet: [FT231XS Datasheet](#)

FT_PROG programming Utility guide: [FT_PROG User Manual](#)

Arduino Open Source Software (IDE) Installation : [Arduino IDE Installation](#)

Arduino IDE programming User Guide: [Arduino IDE Programming User Guide](#)

Arduino Library Installation guide: [Arduino Library Installation Guide](#)

Acronyms and Abbreviations

Terms	Description
DC	Direct Current
LDO	Low Drop Out regulator
LED	Light-emitting diode
MCU	Microcontroller Unit
TQFP	Thin Quad Flat Pack
USB	Universal Serial Bus
UART	Universal Asynchronous Receiver/Transmitter

Appendix B – List of Figures and Tables

List of Tables

Table 1 - Switch Mode	6
Table 2- LED Status	8
Table 3 - Pin Mapping of CN5	9
Table 4 - Pin Mapping of CN7	9
Table 5 - Pin Mapping of CN6	9
Table 6 - Pin Mapping of CN4	10
Table 7 - Temperature Parameter	11
Table 8 – Operating Voltage and Current	11

List of Figures

Figure 1 - NerO Board Top View	5
Figure 2 - DC Power Supply	6
Figure 3 - USB back-voltage block circuit	7
Figure 4 - Atmega328P Micro-controller	7
Figure 5 - FT231XS USB to Serial Converter	8
Figure 6 – NerO Schematic	12
Figure 7 – NerO Board Diagram	13
Figure 8 – NerO PCB Dimensions (Top view)	14
Figure 9 - NerO PCB Dimensions (Side view)	14