



OLIMEXINO-STM32F3

User Manual

Document revision 2.0 September 2022

www.olimex.com

Table of Contents

What is OLIMEXINO-STM32F3.....	3
Hardware schematic, revision C1.....	4
Programming considerations.....	5
Arduino IDE installation.....	5
Software examples and libraries.....	8
Document revision history.....	9

What is OLIMEXINO-STM32F3

OLIMEXINO-STM32F3 is an industrial grade -40+85C operating temperature, Open Source Hardware board with STM32F303RCT6 main chip. The chip has 256 KB of flash memory and 48 KB of RAM. The board works with powered off a Li-Po battery without an external supply, and switching between USB to external to Li-Po battery power supply is seamless and automatic. If USB is connected the board gets powered by the USB, if external power is applied to the power jack – it has priority over the USB and battery and the board will be powered by the external power supply, if both external power supply and USB power supply are missing but a battery is connected the board would automatically get powered by the LiPo battery.

In STM32F3 series of microcontrollers the CAN and the USB can work at the same time.

Notice that this guide is not suitable for OLIMEXINO-GD32F3!

OLIMEXINO-STM32F3 has following features:

- STM32F303RCT6 256KB flash, 40KB RAM
- Industrial grade (-40+85)°C operating temperature
- Micro USB connector for powering and programming
- Power jack (5.5mm x 2mm) for external power supply (4.2-40)V DC
- Li-Po battery charger and connector
- Micro SD card
- RTC 32.768kHz with CR2032 battery connector
- Bootloader button
- Reset Button
- CAN driver and connector
- UEXT connector
- Arduino connectors
- Extra 16 pin GPIO connector
- 10-pin JTAG connector for programming and debugging

Product page:

<https://www.olimex.com/Products/Duino/STM32/OLIMEXINO-STM32F3/open-source-hardware>

Hardware schematic, revision C1

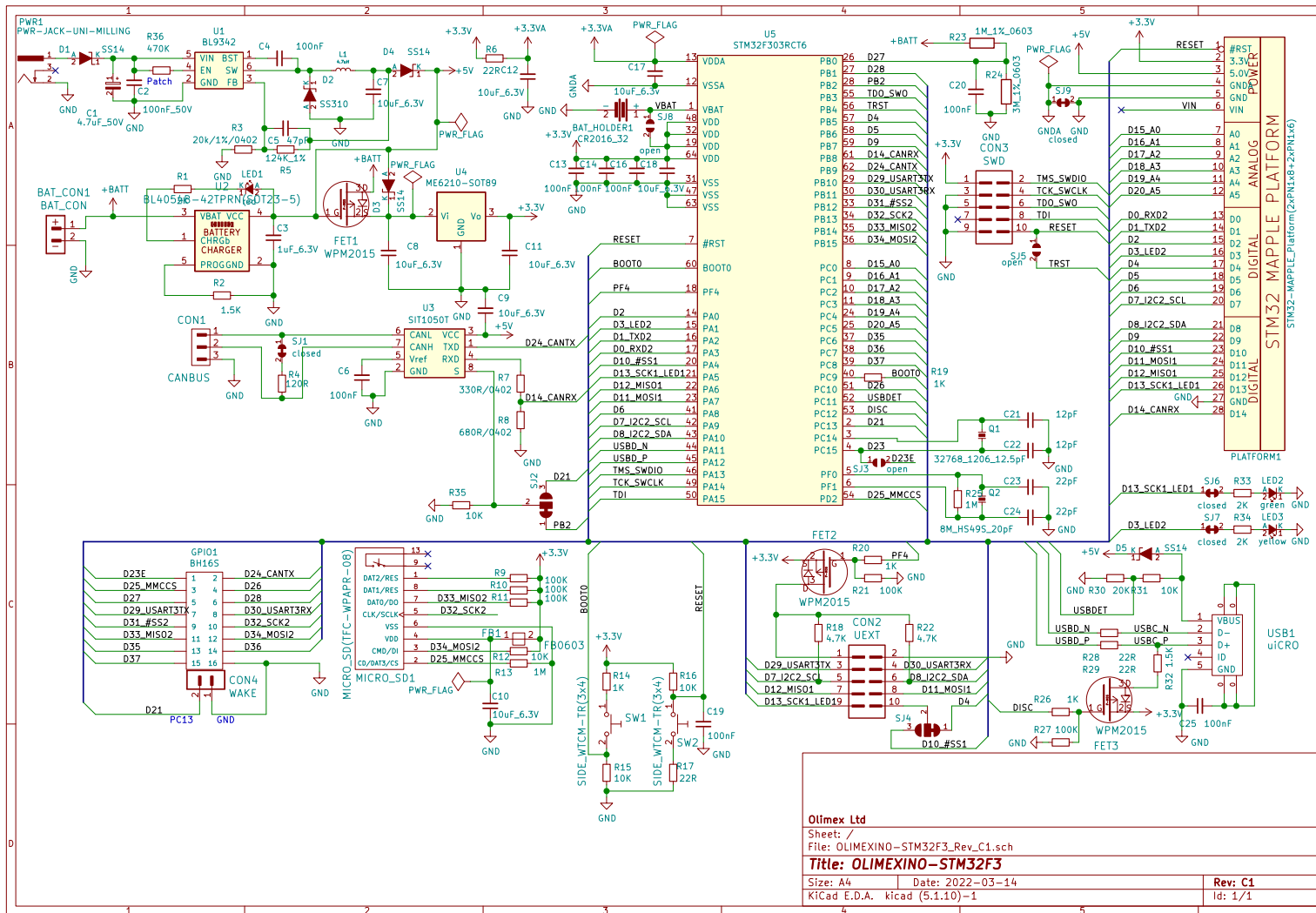

Programming considerations

OLIMEXINO-STM32F3 can be programmed via a number of ways. It can be programmed via JTAG or SWD tool using its 10-pin JTAG connector; it can be programmed via the built-in USB or serial bootloader. A lot of software tools can be used. For simple programming and re-programming tasks maybe consider “STM32CubeProgrammer” stand-alone programmer software. For development work again a lot of software tools can be used depending on the goals and proficiency of the user. We would provide information about how you can program the board with Arduino IDE:

Arduino IDE installation

1. In Arduino IDE navigate to Files → Preferences and in “Additional Boards Manager URLs” field add the following link:

https://github.com/stm32duino/BoardManagerFiles/raw/main/package_stmicroelectronics_index.json

as shown below:

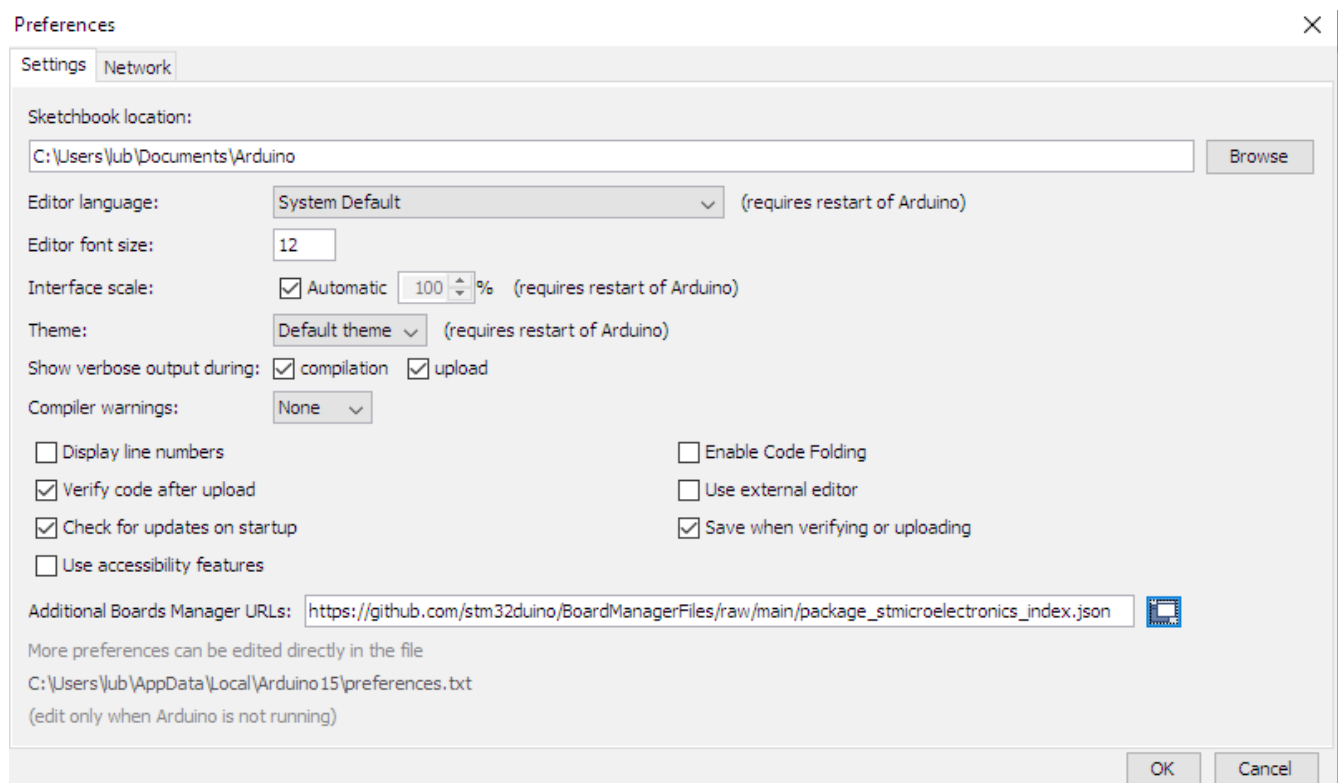

2. Then navigate to Tools → Boards → Board Manager

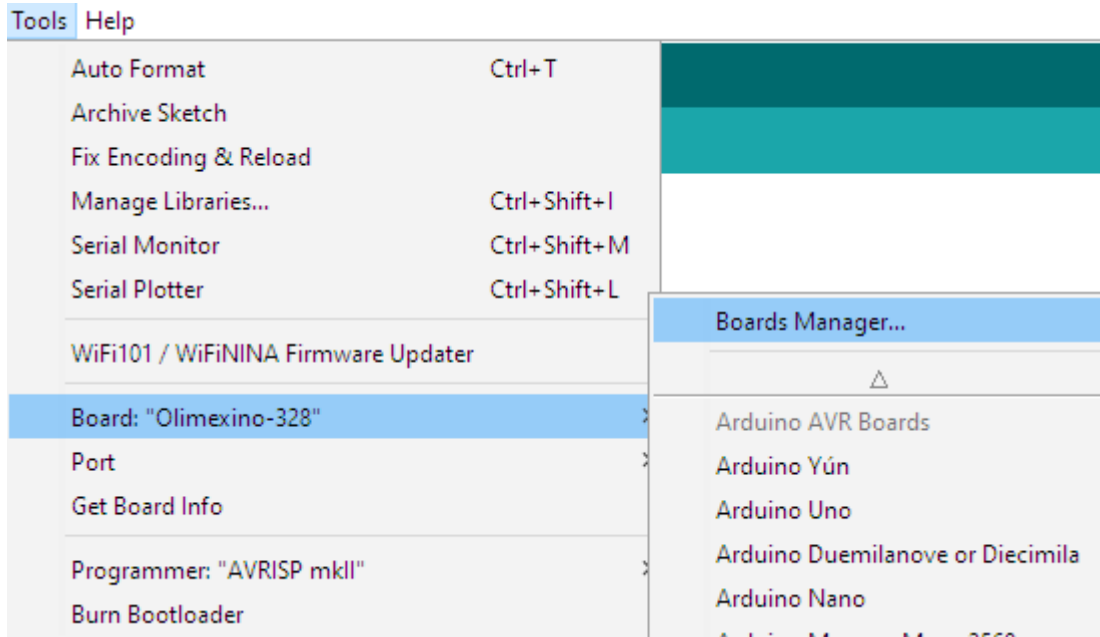

3. Type “stm32” to filter out the available packages then install the latest one made by STMicroelectronics. Wait until installations completes. It should look similar to this:

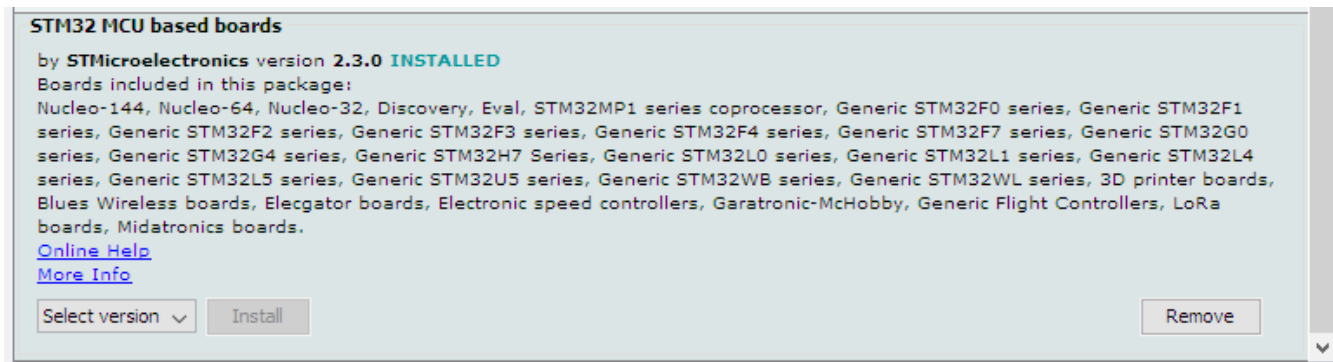

4. We want to upload the demo via USB DFU. And if you wish to upload via SWD, Serial, or DFU you need to install [STM32 Cube Programmer](#) – make sure to download and install it.

5. Restart Arduino IDE.

6. Now select the board. Under “Board” select “Generic STM32F3 series” and under “Board part number:” go for “OLIMEXINO-STM32F3”. Under upload method remember to select DFU, which is the microUSB method (alternatively you can also serial method but that requires Serial-USB adapter attached to the GND, RX, TX pins at the UEXT connector). Follow the image below:

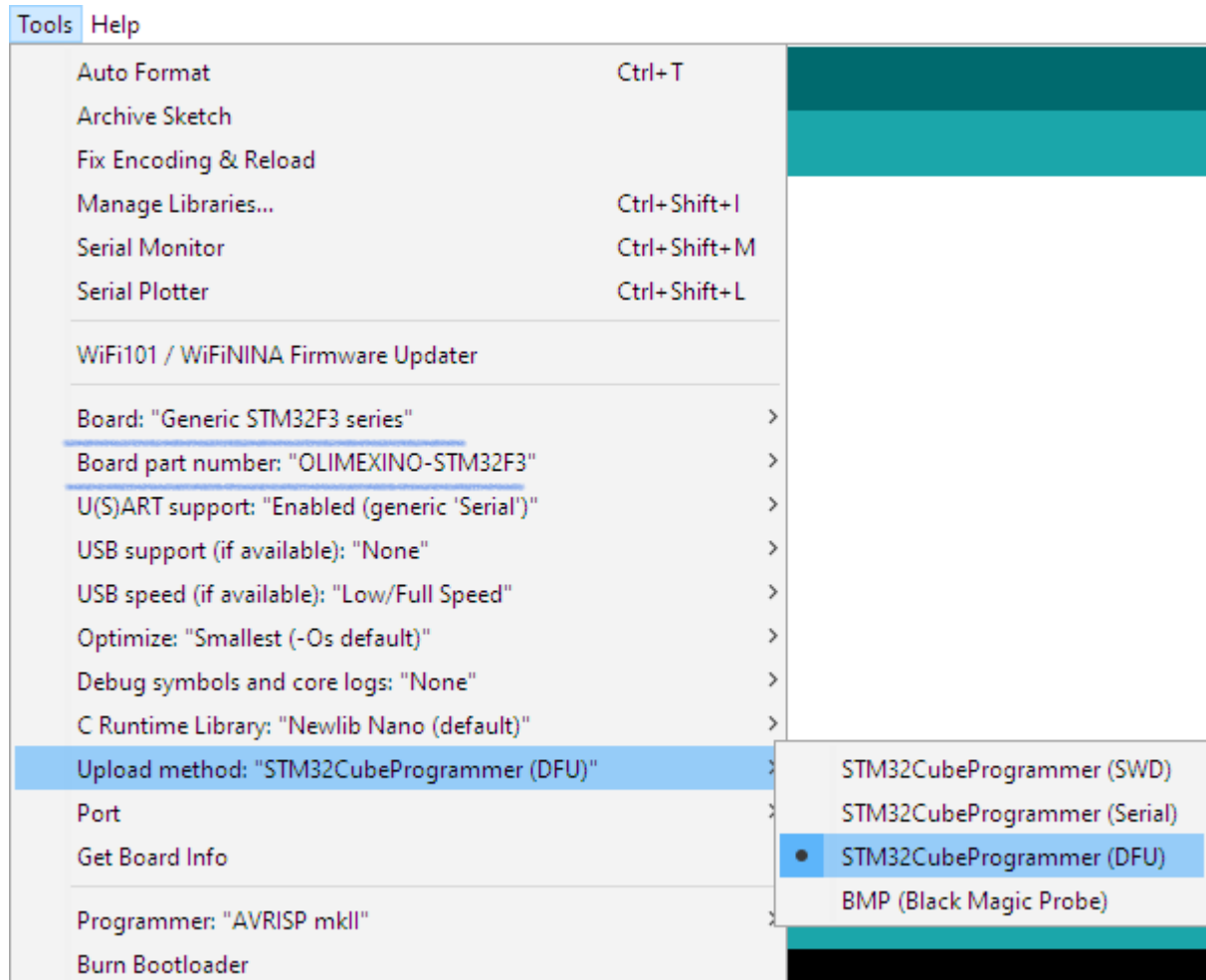

7. Put the board in USB DFU mode – this is done by button manipulation – press and hold down button SW1 then press and release button SW2, then release button SW1. The board should now be recognized as “STM32 bootloader”.

8. Load one of the examples from File → Examples. Maybe Examples → 01.Basics → Blink. Click the upload button and wait until success.

If you encounter issues with the installation make sure to also check the official installation instructions:

<https://github.com/stm32duino/wiki/wiki/Getting-Started>

Software examples and libraries

You can find our work here:

<https://github.com/OLIMEX/OLIMEXINO-STM32F3/tree/master/SOFTWARE>

In GitHub software folder there are examples on how to use the GPIOs (LEDs and button), I2C, SPI (we provide new library for this as otherwise you couldn't use the micro SD card as original Arduino library support just one SPI), CAN, UART, SD-card, LCD3310.

There is also an example with MOD-LCD2.8RTP.