

DATA SHEET

OLS500: Hermetic Surface Mount High CMR, High-Speed Logic Gate Optocoupler

Features

- Performance guaranteed over $-55\text{ }^{\circ}\text{C}$ to $+125\text{ }^{\circ}\text{C}$ ambient temperature range
- Guaranteed minimum Common Mode Rejection (CMR) transient immunity, $>1000\text{ V}/\mu\text{s}$
- $1500\text{ V}_{\text{DC}}$ electrical isolation
- Low-Power Schottky Transistor-Transistor Logic (LSTTL)/ Transistor-to-Transistor Logic (TTL) compatible
- High-speed, 10 Mbps typical
- Low input LED current
- Similar to 6N134, 6N137, and HCPL2601
- Offers 100% high reliability screenings

Description

The OLS500 is suitable for high-speed digital interfacing applications, elimination of ground loops, and input/output buffering. Each OLS500 has an LED and integrated high-speed detector mounted and coupled in a custom hermetic surface mount Leadless Chip Carrier (LCC) ceramic package, that provides $1500\text{ V}_{\text{DC}}$ electrical isolation between the input and output.

The light from the LED is collected by the photodiode in the integrated detector and amplified by a high gain linear amplifier that drives a Schottky-clamped open collector output transistor. Typical propagation delay for the OLS500 is 60 ns. The internal shield improves common mode transient immunity to 1000 V/ μs minimum.

Device mounting is achieved with reflow soldering or conductive epoxies.

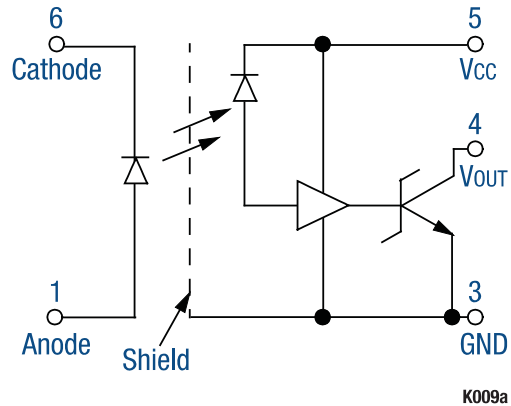

Figure 1. OLS500 Block Diagram

Figure 1 shows the OLS500 functional block diagram. Table 1 provides the OLS500 absolute maximum ratings. Table 2 provides the OLS500 electrical specifications.

Figures 2 through 5 illustrate the OLS500 typical performance characteristics. Figure 6 shows the OLS500 switching test circuit. Figure 7 provides the OLS500 package dimensions.

Table 1. OLS500 Absolute Maximum Ratings (Note 1)

Parameter	Symbol	Minimum	Maximum	Units
<i>Coupled</i>				
Input to output isolation voltage	V _{DC}	-1500	+1500	V
Storage temperature range	T _{STG}	-65	+150	°C
Operating temperature range	T _A	-55	+125	°C
Mounting temperature range (3 minutes maximum)			+240	°C
Total power dissipation	P _D		+170	mW
<i>Input Diode</i>				
Average input current	I _{DD}		20	mA
Peak forward current (≤1 ms duration)	I _F		40	mA
Reverse voltage	V _R		5	V
Power dissipation	P _D		36	mW
<i>Output Detector</i>				
Peak output current			25	mA
Supply voltage (1 minute maximum)	V _{CC}		7	V
Output collector power dissipation	P _D		40	mW

Note 1: Exposure to maximum rating conditions for extended periods may reduce device reliability. There is no damage to the device with only one parameter set at the limit and all other parameters set at or below their nominal value. Exceeding any of the limits listed here may result in permanent damage to the device.

CAUTION: Although this device is designed to be as robust as possible, electrostatic discharge (ESD) can damage this device. This device must be protected at all times from ESD. Static charges may easily produce potentials of several kilovolts on the human body or equipment, which can discharge without detection. Industry-standard ESD precautions should be used at all times.

Table 2. OLS500 Electrical Specifications (Note 1)
(T_A = -55 °C to +125 °C, Unless Otherwise Noted)

Parameter	Symbol	Test Condition	Minimum	Typical	Maximum	Units
Low level output voltage (Note 2)	V _{OL}	V _{CC} = 5.5 V, I _{OL} = 10.0 mA, I _F = 5.0 mA		0.4	0.6	V
High level output current (Note 2)	I _{OH}	V _{CC} = V _O = 5.5 V, I _F = 250.0 μA		5.0	250.0	μA
High level supply current (Note 2)	I _{CCH}	V _{CC} = 5.5 V, I _F = 0 mA		11.0	16.0	mA
Low level supply current (Note 2)	I _{CCL}	V _{CC} = 5.5 V, I _F = 5.0 mA		16.0	20.0	mA
Input:						
Forward voltage	V _F	I _F = 10.0 mA	3	1.8	2.5	V
Reverse breakdown voltage	B _{VR}	I _R = 10 μA		V		
Output leakage current (Note 3)	I _{L0}	R _H ≤ 50%, T _A = 25 °C, V _{L0} = 1500 V _{DC}		1	μA	
Propagation delay time (Note 2):						
Logic high to low	t _{PHL}	I _F = 7.5 mA, V _{CC} = 5.0 V, R _L = 510.0 Ω		60.0	140.0	ns
Logic low to high	t _{PLH}	I _F = 7.5 mA, V _{CC} = 5.0 V, R _L = 510.0 Ω		60.0	140.0	ns
Common mode transient immunity (Note 2):						
High output level	CM _H	V _{CM} = 50.0 V peak, V _O (minimum) = 2.0 V, R _L = 510.0 Ω, I _F = 0 mA, T _A = 25 °C	1000	10,000		V/μs
Low output level	CM _L	V _{CM} = 50.0 V peak, V _O (maximum) = 0.8 V, R _L = 510.0 Ω, I _F = 5.0 mA, T _A = 25 °C	1000	10,000		V/μs

Note 1: Performance is guaranteed only under the conditions listed in the above table.

Note 2: A ceramic bypass capacitor (0.01 μF to 0.1 μF) is required between pins 3 and 5 to stabilize the operation of the amplifier.

Note 3: Measured between pins 1, 2, and 6 shorted together, and pins 3, 4, and 5 shorted together. T_A = 25°C and duration = 1 s.

Typical Performance Characteristics

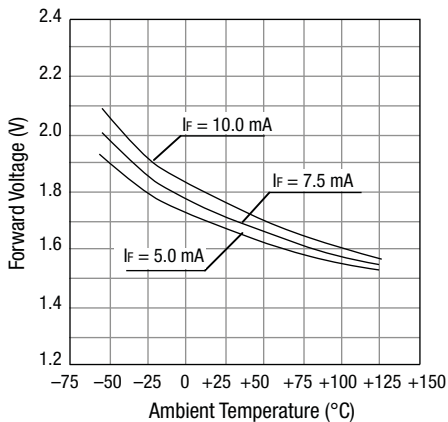

Figure 2. Input Diode Forward Voltage vs Temperature

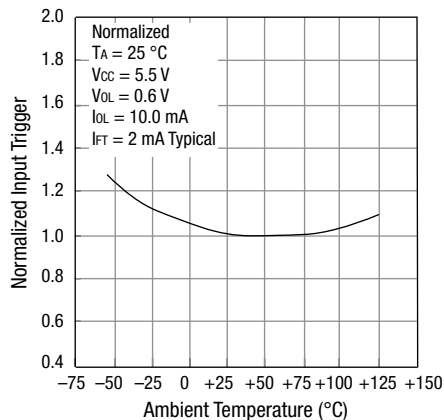

Figure 3. Normalized Input Trigger Current vs Temperature

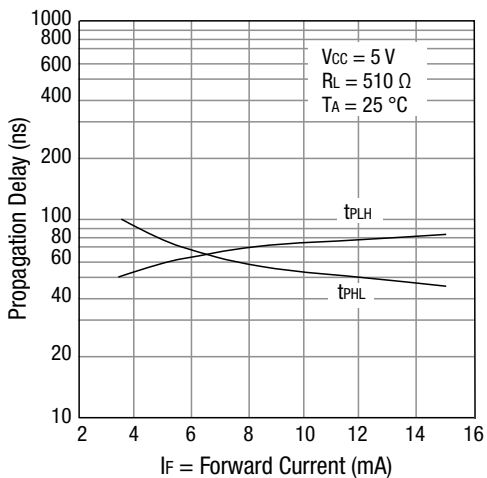

Figure 4. Propagation Delay vs Input Forward Current

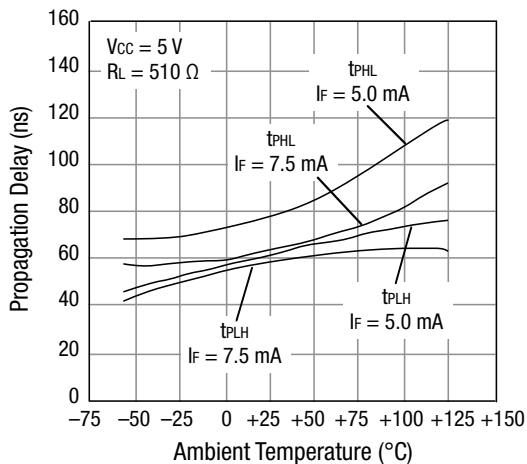

Figure 5. Propagation Delay vs Temperature

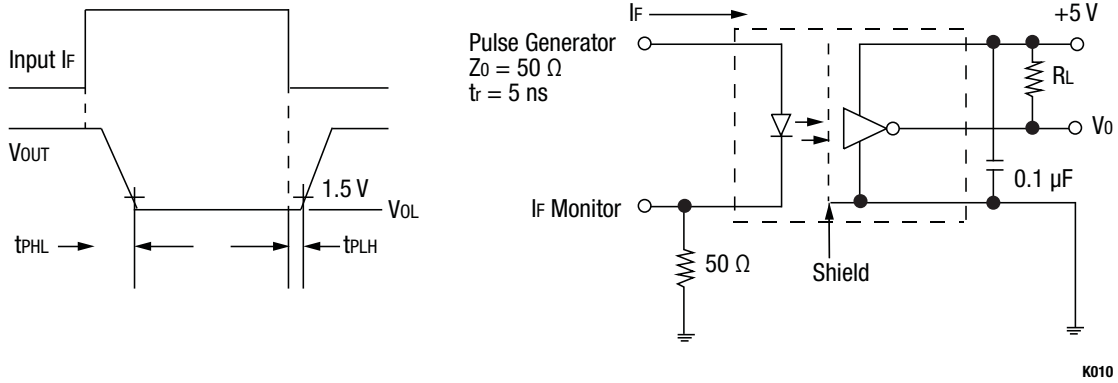

Figure 6. OLS500 Switching Test Circuit

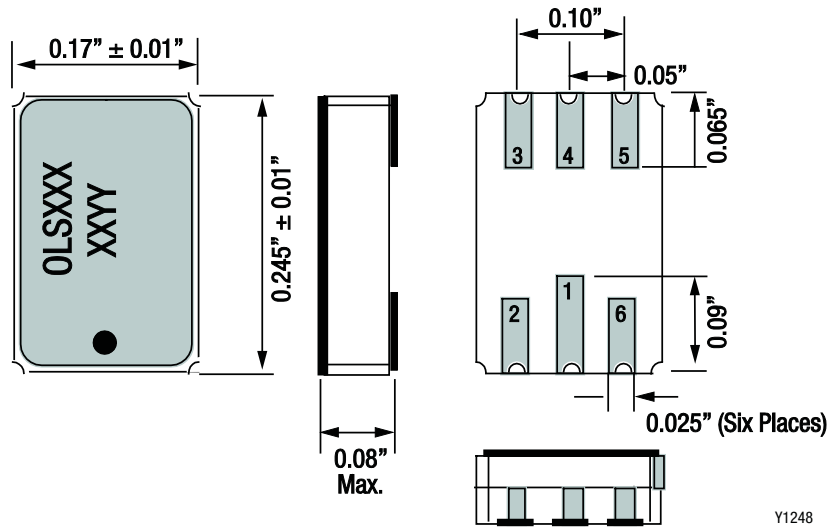

Figure 7. OLS500 Package Dimensions