

PRESSURE TRANSDUCERS

P-3000S

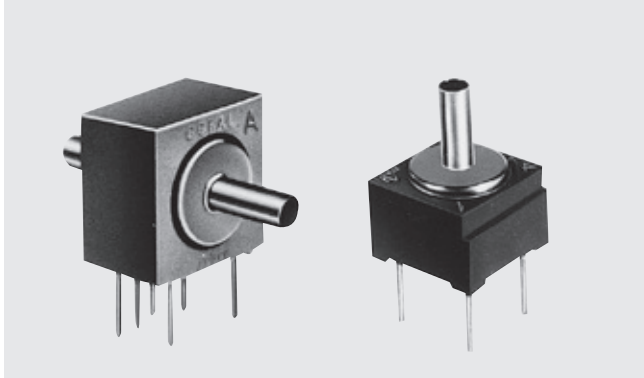

FEATURES

- For non-corrosive gases
- Built-in temp. compensation function (0 ~ 50 °C)
- Three pressure reference to choose from Gauge, Differential and Absolute pressure
- Compact and light weight
- PC board mountable

INTERNAL STRUCTURE (Gauge type)

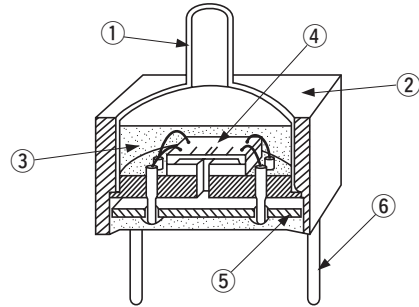

Part name	Material
1 Pressure port	Iron/Nickel alloy + Nickel-plated
2 Housing	PBT (Polybutyleneterephthalate)
3 Resin compound	Silicone gel
4 Sensor chip	Silicone
5 Resistor board for temp. compensation	Ceramic
6 Terminal pin	Copper + solder-plated

MODEL NUMBER DESIGNATION

P-3000S - 501 G - 02

Series name

Rated pressure range

500 : 0 ~ 4.9 kPa {0 ~ 0.05 kgf/cm²} 102 : 0 ~ 98.1 kPa {0 ~ 1 kgf/cm²}
 101 : 0 ~ 9.81 kPa {0 ~ 0.1 kgf/cm²} *502 : 0 ~ 490 kPa {0 ~ 5.0 kgf/cm²}
 351 : 0 ~ 34.3 kPa {0 ~ 0.35 kgf/cm²} *702 : 0 ~ 686 kPa {0 ~ 7.0 kgf/cm²}
 501 : 0 ~ 49.0 kPa {0 ~ 0.5 kgf/cm²}

* ... Built-to-order

Thermal error

02 : ± 0.02 % F.S./°C 10 : ± 0.10 % F.S./°C
 04 : ± 0.04 % F.S./°C

Pressure reference

G : Gauge
 D : Differential
 A : Absolute

LIST OF MODEL NUMBERS

Pressure reference	Gauge						Differential			Absolute		
	kPa {kgf/cm ² } Rated pressure range	0 ~ 4.9 {0 ~ 0.05}	0 ~ 9.81 {0 ~ 0.1}	0 ~ 49.0 {0 ~ 0.5}	0 ~ 98.1 {0 ~ 1}	0 ~ 490 {0 ~ 5.0}	0 ~ 686 {0 ~ 7.0}	0 ~ ± 9.81 {0 ~ ± 0.1}	0 ~ ± 49.0 {0 ~ ± 0.5}	0 ~ ± 98.1 {0 ~ ± 1}	0 ~ 34.3 {0 ~ 0.35}	0 ~ 98.1 {0 ~ 1}
± 0.02 % F.S./°C	/	/	P-3000S -501G-02	P-3000S -102G-02	/	/	/	P-3000S -501D-02	P-3000S -102D-02	/	/	/
± 0.04 % F.S./°C	P-3000S -500G-04	P-3000S -101G-04	P-3000S -501G-04	P-3000S -102G-04	→ P-3000S -502G-04	→ P-3000S -702G-04	P-3000S -101D-04	P-3000S -501D-04	P-3000S -102D-04	P-3000S -351A-04	P-3000S -102A-04	/
± 0.1 % F.S./°C	/	P-3000S -101G-10	P-3000S -501G-10	P-3000S -102G-10	/	/	P-3000S -101D-10	P-3000S -501D-10	P-3000S -102D-10	P-3000S -351A-10	P-3000S -102A-10	/

☐ : Not available

※ Verify the above model numbers when placing orders.

→ The products marked → are built-to-order items. Please contact us separately to buy these products.

P-3000S

PRESSURE TRANSDUCERS

■ 標準仕様 STANDARD SPECIFICATIONS

● 特記ない場合、周囲温度 25 ± 5℃、駆動電流 1.5 mA DC で規定します。
 Unless otherwise specified, the specs are defined at an ambient temperature of 25±5 °C and excitation current of 1.5 mA DC.

Item		Model number	P-3000S										
			500G	101G	501G	102G	502G	702G	101D	501D	102D	351A	102A
General specifications	Pressure reference		Gauge					Differential			Absolute		
	Rated pressure range	kPa {kgf/cm ² }	4.9 {0.05}	9.81 {0.1}	49.0 {0.5}	98.1 {1.0}	490 {5.0}	686 {7.0}	± 9.81 {± 0.1}	± 49.0 {± 0.5}	± 98.1 {± 1.0}	34.3 (abs) {0.35}	98.1 (abs) {1.0}
	Maximum pressure	kPa {kgf/cm ² }	9.8 {0.1}	19.6 {0.2}	98.1 {1.0}	196 {2.0}	981 {10}	1372 {14}	19.6 {0.2}	98.1 {1.0}	196 {2.0}	103 (abs) {1.05}	196 (abs) {2.0}
	Break-down pressure	kPa {kgf/cm ² }	24.5 {0.25}	49.0 {0.5}	245 {2.5}	490 {5.0}	1471 {15}	2058 {21}	49.0 {0.5}	245 {2.5}	490 {5.0}	147 (abs) {1.5}	490 (abs) {5.0}
	Operating temp. range	°C	- 20 ~ 100										
	Compensated temp. range	°C	0 ~ 50										
	Operating humidity	%RH	35 ~ 85 (No condensation)										
	Storage temp.	°C	- 40 ~ 120 (Atmospheric pressure, humidity 65 %RH maximum)										
	Bridge resistance	Ω	4700 ± 30 %										
	Pressure medium		Non-corrosive gases										
	Insulation resistance	MΩ minimum	100 (50 V DC)										
	Dielectric strength		50 V AC, 60 s (Leakage current 1 mA maximum)										
	Pressure port	mm	φ 3.5										
	Net weight	g	Approx. 5					Approx. 7			Approx. 5		
Power	Excitation current	mA DC	1.5 (Constant current)										
Analog output	Offset voltage	mV	± 3								± 5		
	Span voltage	mV	70 ± 30	50 ± 20	100 ± 30			50 ± 20	100 ± 30		80 ± 40		
	Linearity/Hysteresis	%F.S.	± 0.5	± 0.3	± 0.25		± 0.5		± 0.3		± 0.5		
	Thermal error (Reference temp.: 25 °C)	ZERO %F.S./°C	± 0.04	± 0.04/0.1	± 0.02/0.04/0.1		± 0.04		± 0.04/0.1	± 0.02/0.04/0.1		± 0.04/0.1	
		SPAN %F.S./°C	± 0.04	± 0.04/0.1	± 0.02/0.04/0.1		± 0.04		± 0.04/0.1	± 0.02/0.04/0.1		± 0.04/0.1	
Response	ms	Approx. 1											

■ ENVIRONMENTAL CHARACTERISTICS

Test item	Test conditions (At 25 ± 5 °C)	Permissible change
Vibration	10 ~ 500 Hz, 1.5 mm maximum/98.1 m/s ² , 3 directions for 2 hours each	Offset voltage/Span voltage: ±1 %F.S. maximum each
Shock	981 m/s ² , 3 directions for 3 times each	
Pressure cycling	0 ~ Rated pressure, 10 ⁶ cycles	
Moisture resistance	40 °C, 90 ~ 95 %RH, 240 hrs.	

※ P-3000S series can be operated at the vacuum pressure.