

HSMC-NET

Terasic HSMC-NET Daughter Board

User Manual

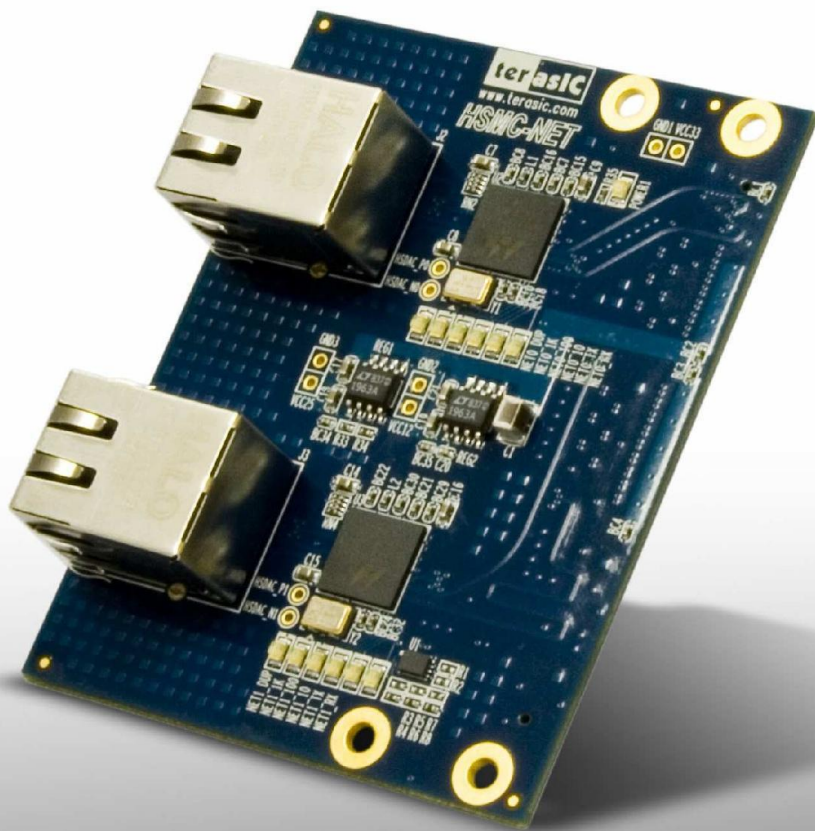

Chapter 1	Introduction.....	2
1.1	Features.....	2
1.2	About the KIT.....	3
1.3	Assemble the HSMC-NET Board.....	4
1.4	Getting Help.....	5
Chapter 2	Architecture.....	6
2.1	Layout and Componets.....	6
2.2	Block Diagram.....	7
Chapter 3	Board Components.....	9
3.1	The HSMC-NET Connector.....	9
3.2	I2C Serial EEPROM.....	15
Chapter 4	Demonstrations.....	16
4.1	Introduction.....	16
4.2	How the Demonstration is built.....	17
4.3	System Requirements.....	25
4.4	Setup the Demonstration.....	25
4.5	Demo Operation.....	26
4.6	Overview.....	28
4.7	Nios Program.....	29
Chapter 5	Appendix.....	31
5.1	Revision History.....	31
5.2	Always Visit HSMC-NET Webpage for New Main board.....	31

Introduction

The Terasic HSMC-NET is a Gigabit Ethernet transceiver with a High Speed Mezzanine Connector (HSMC) interface. It offers network transfers of up to 1 Gbps with the host board using a HSMC connector. Also, it provides a fully integrated Ethernet solution enabling fast implementation design, shortening development times, and allows you to focus on the core functions of the system design. Lastly, the HSMC-NET can be connected any HSMC/HSTC interfaces.

1.1 Features

Figure 1-1 shows the photo of the HSMC-NET board. The important features are listed below:

- One HSMC connector for interface conversion, which is fully compatible with Cyclone III Starter Kit and DE3 host boards
- Dual-Port Integrated 10/100/1000 Gigabit Ethernet transceiver Supports GMII/MII/RGMII/TBI MAC interfaces for direct connection to a MAC/Switch port
- Dynamically configurable to support 10Mbps, 100Mbps (Fast Ethernet) or 1000Mbps (Gigabit Ethernet) operation
- Uses standard Cat 5 UTP (unshielded twisted pair) cabling
- Requires a 25-MHz reference clock driven from a dedicated oscillator
- Complete Reference Designs



Figure 1-1 The HSMC-NET board

1.2 About the KIT

This section describes the package content

- HSMC-NET board x 1
- System CD-ROM x 1

The CD contains technical documents of the HSMC-NET, and one reference design along with the source code.

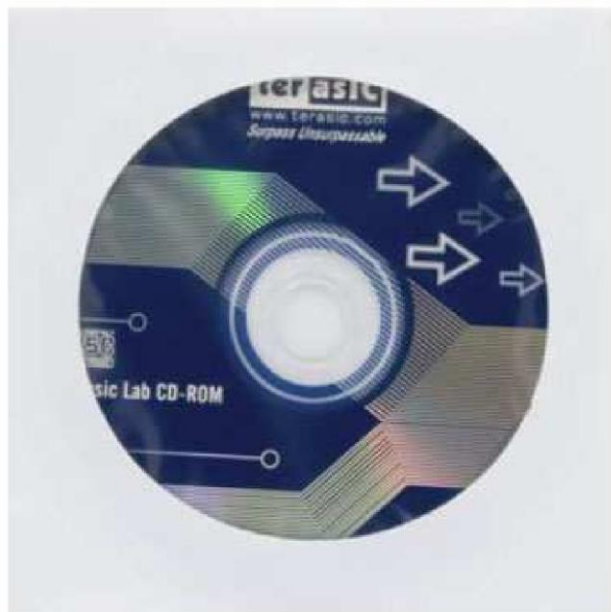

Figure 1-2 HSMC-NET Package

1.3 Assemble the HSMC-NET Board

This section describes how to connect the HSMC-NET daughter board to a main board, and using DE3 as an example shown in **Figure 1-4**.

The HSMC-NET daughter board connects to the main boards through the HSMC interface. For the DE3, the HSMC-NET can be connected to any DE3's four HSTC connectors using a THCB-HFF adapter card (**Figure 1-3**) which can be found in the DE3 package.



Figure 1-3 THCB-HFF adapter card

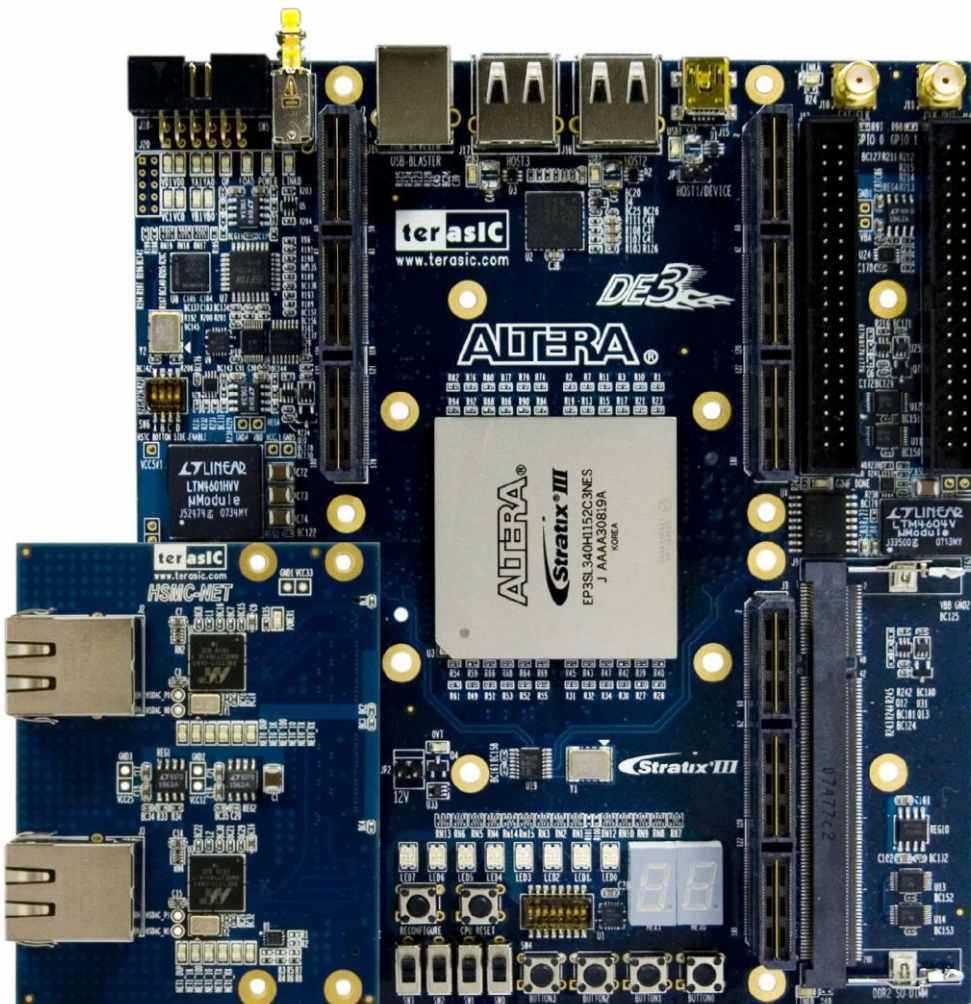

Figure 1-4 The DE3 board connected to the HSMC-NET daughter board



Note. Do not attempt to connect/remove the HSMC-NET daughter board to/from the main the main board when the power is on, or else the hardware could be damaged.

1.4 Getting Help

Here are some places to get help if you encounter any problem:

- Email to support@terasic.com
- Taiwan & China: +886-3-550-8800
- Korea : +82-2-512-7661
- Japan: +81-428-77-7000

Architecture

This Chapter covers the architecture of the HSMC-NET board including its PCB and block diagram.

2.1 Layout and Components

The picture of the HSMC-NET board is shown in **Figure 2-1** and **Figure 2-2**. It depicts the layout of the board and indicates the location of the connectors and key components.

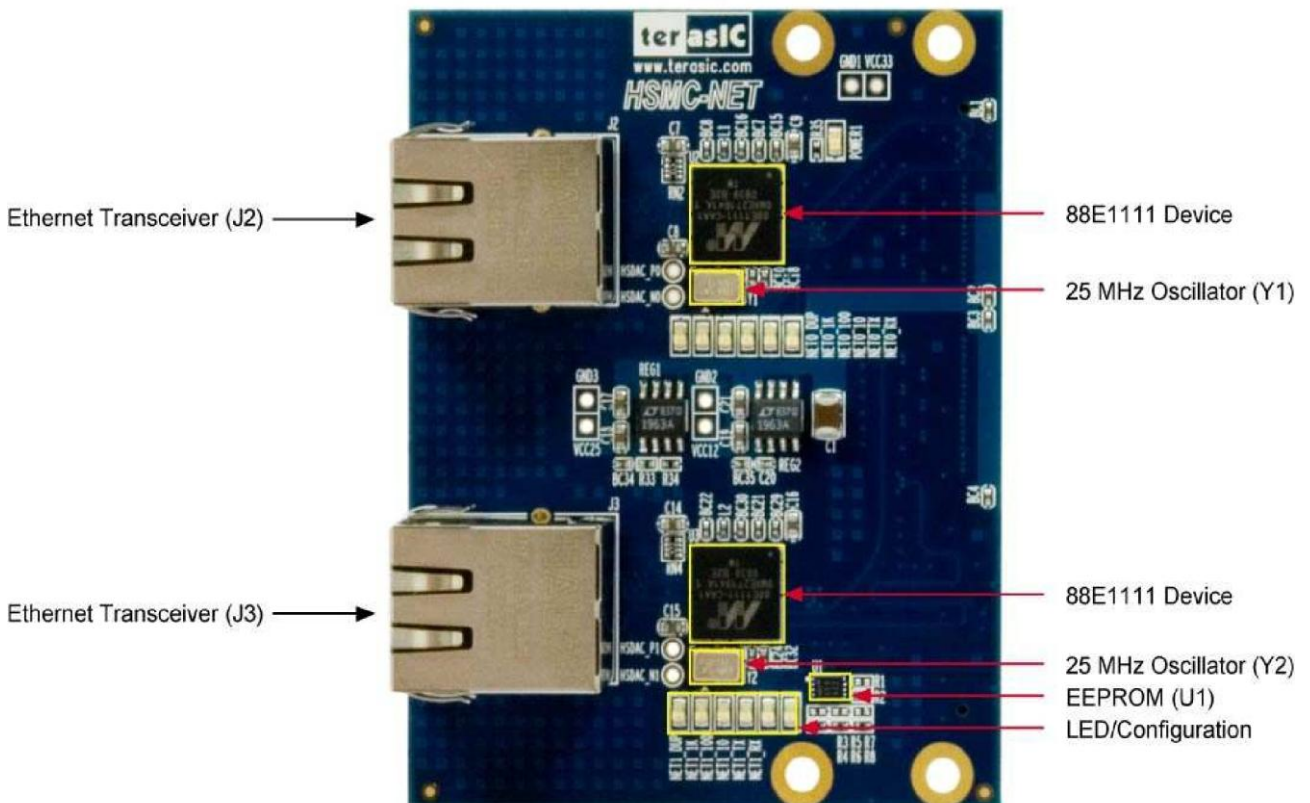

Figure 2-1 The HSMC-NET PCB and component diagram

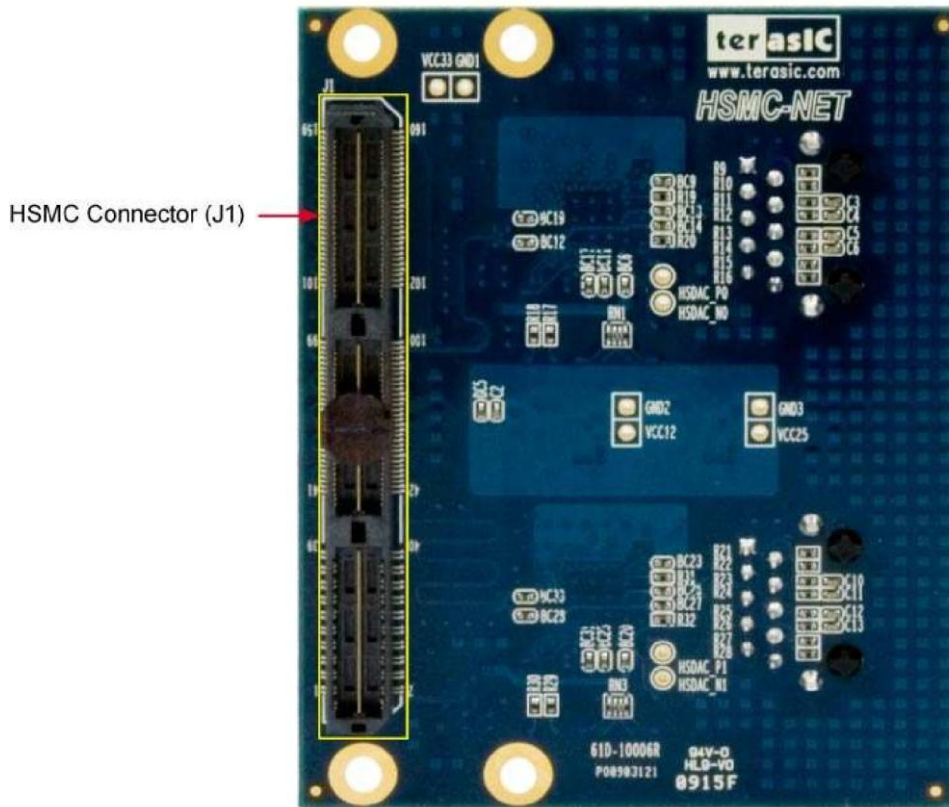

Figure 2-2 The HSMC-NET Back side – HSMC connector view

The following components are provided on the HSMC-NET board :

- Ethernet Transceiver (J2/J3)
- 25MHz Oscillator (Y1/Y2)
- HSMC expansion connector (J1)
- Marvell 88E1111 Ethernet Device (U2/U3)
- Voltage Regulator (REG1/REG2)
- I2C EEPROM (U1)
- LED/Configuration

2.2 Block Diagram

Figure 2-3 shows the block diagram of the HSMC-NET board

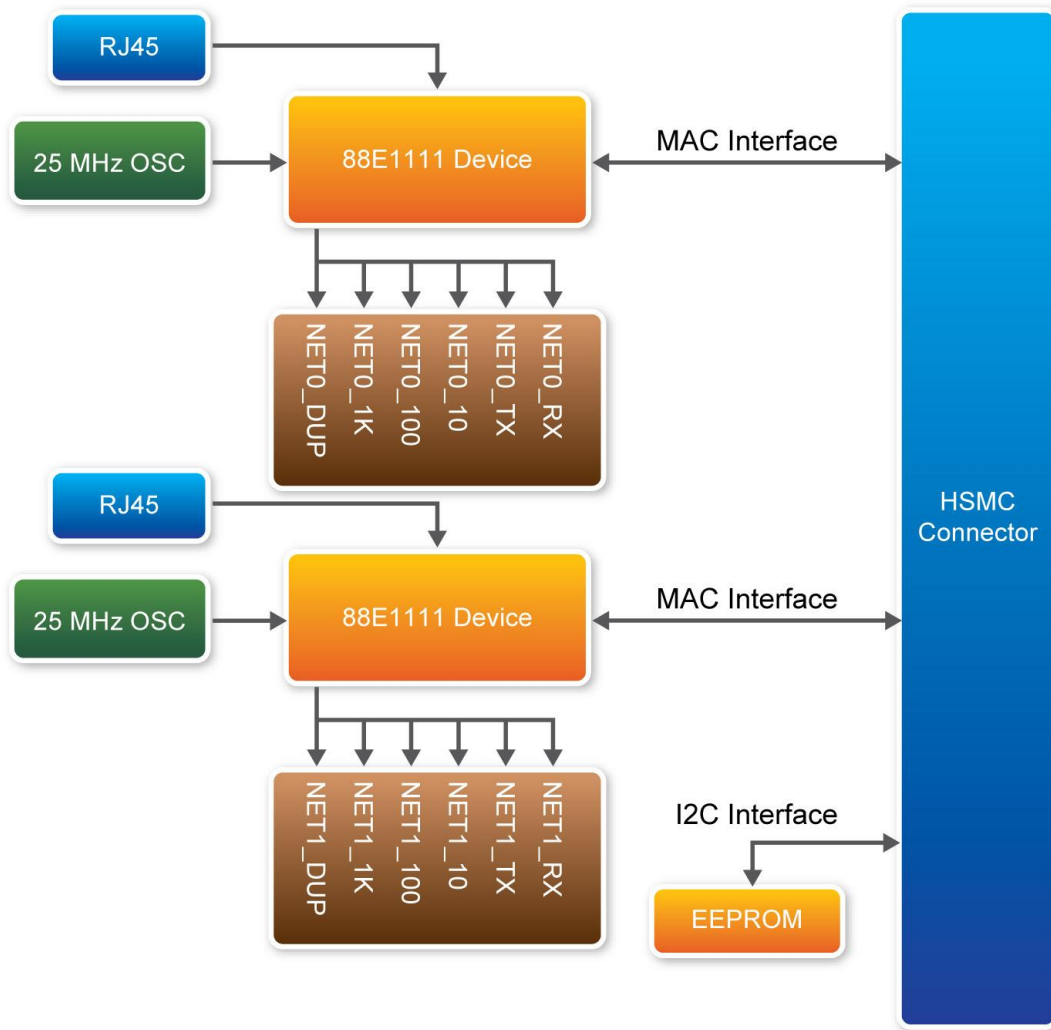

Figure 2-3 The block diagram of the HSMC-NET board

Chapter 3

Board Components

This section illustrates the detailed information of the components, connector interfaces, and the pin mapping tables of the HSMC-NET board

3.1 The HSMC-NET Connector

- **This section describes pin definition of the HSMC-NET interface onboard**

All the control and data signals of the Ethernet transmitter and receiver are connected to the HSMC connector, so users can fully control the HSMC daughter board through the HSMC interface. Power is derived from 3.3V and 12V of the HSMC connector.

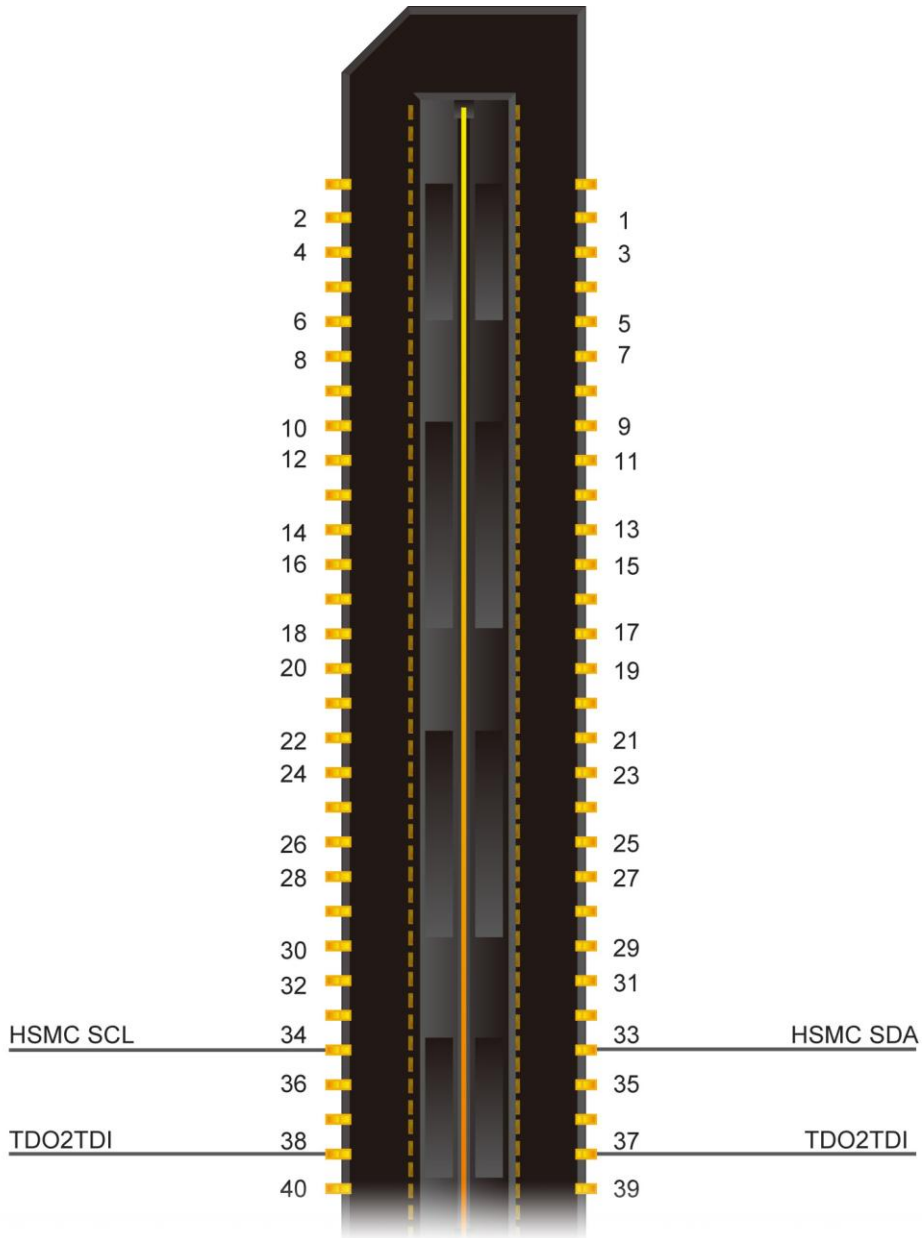

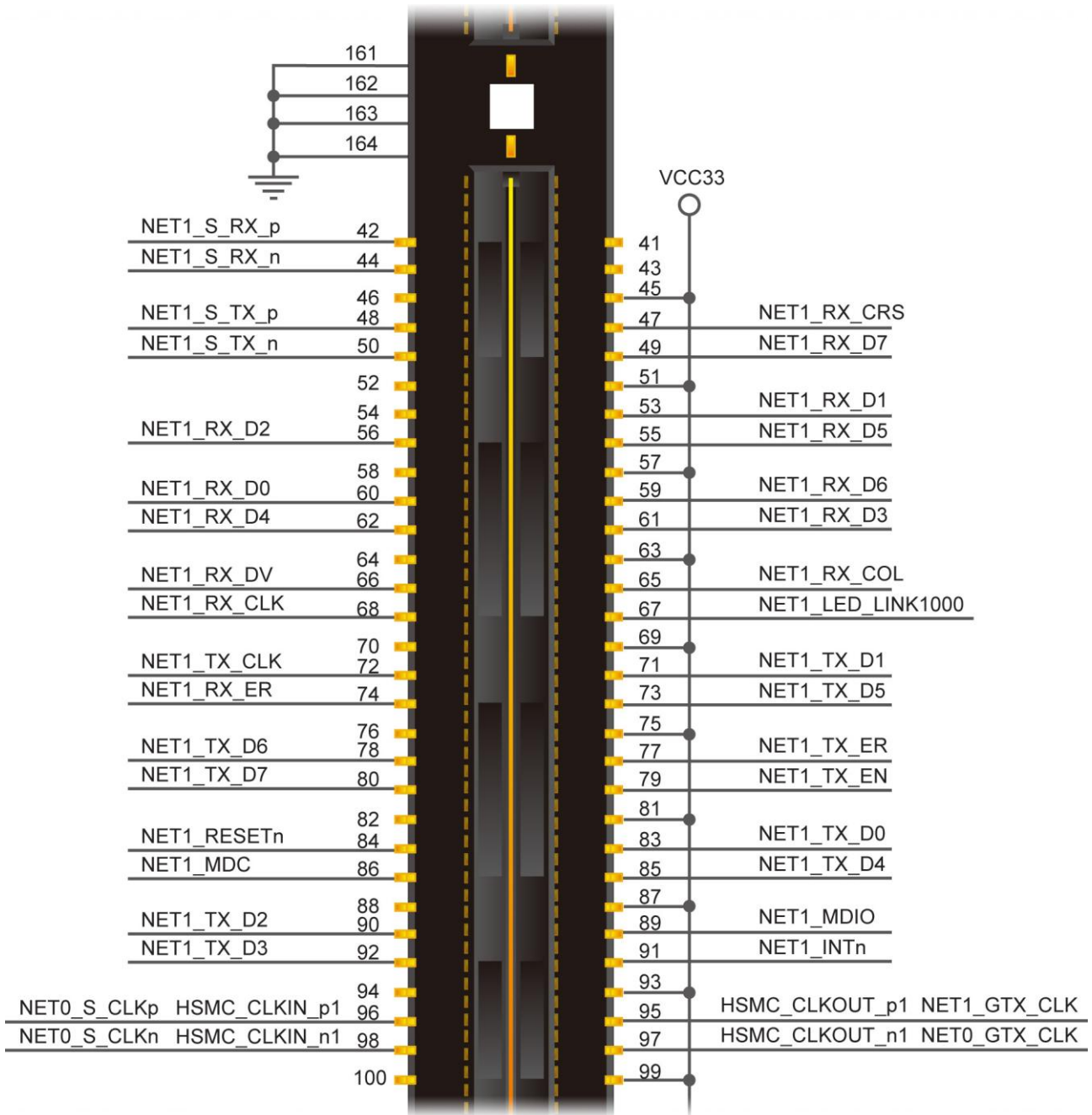

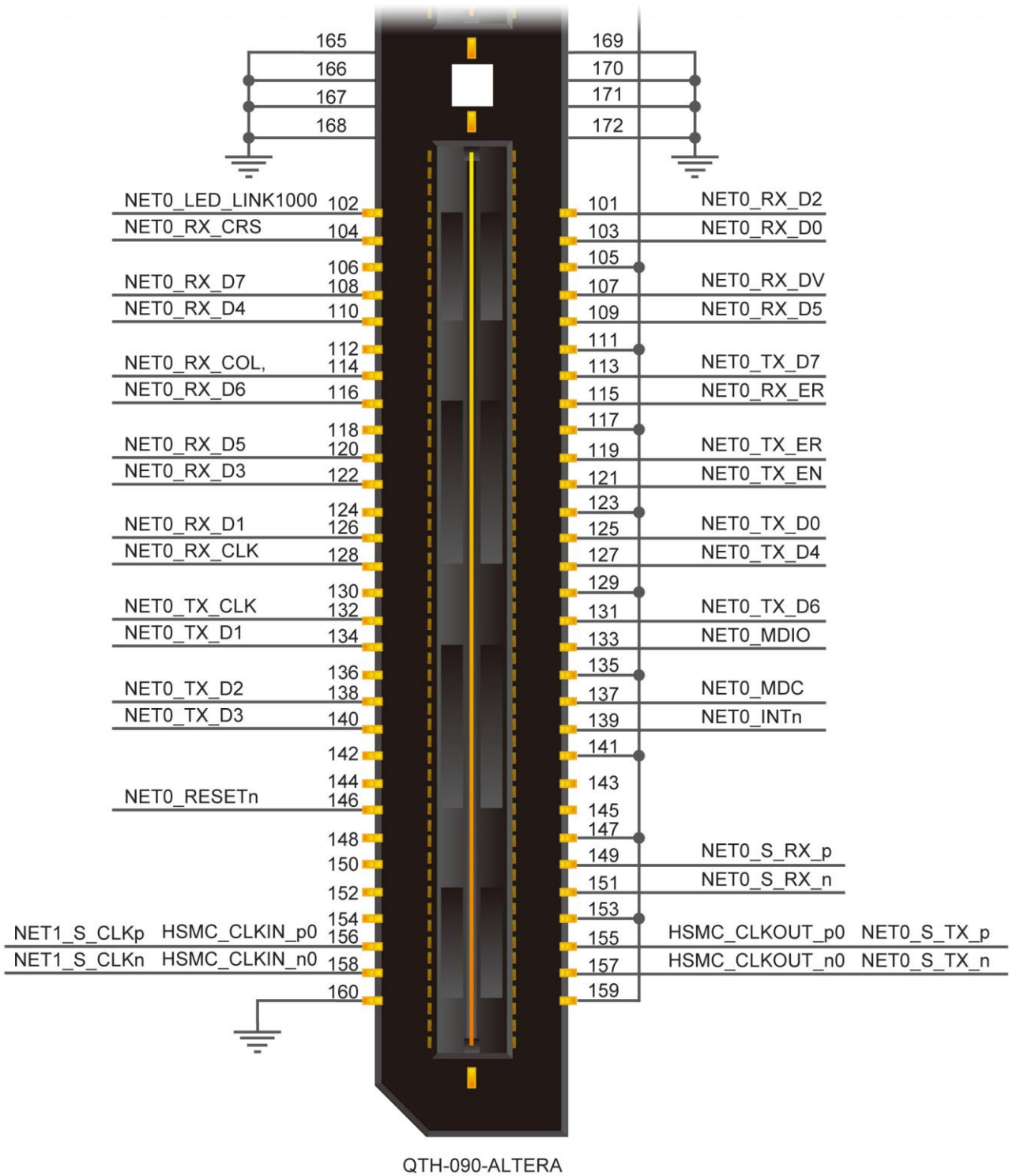

QTH-090-ALTERA
Figure 3-1 The pin-outs on the HSMC connector

The **Table 3-1** below lists the HSMC signal direction and description.



*Note. The power pins are not shown in the **Table 3-1***

Table 3-1 The pin assignments for the HSMC connector (J1)

<i>Signal Name</i>	<i>HSMC Pin</i>		<i>Description</i>
	<i>Number</i>	<i>Direction</i>	
NET1_S_RX_p	42	Input	SGMII receive data positive (Ethernet 1)
NET1_S_RX_n	44	Input	SGMII receive data negative (Ethernet 1)
NET1_RX_CRS	47	Input	Carrier Sense pin (Ethernet 1)
NET1_S_TX_p	48	Output	SGMII transmit data positive (Ethernet 1)
NET1_RX_D7	49	Input	Receive code group bit 7 (Ethernet 1)
NET1_S_TX_n	50	Output	SGMII transmit data negative (Ethernet 1)
NET1_RX_D1	53	input	Receive code group bit 1 (Ethernet 1)
NET1_RX_D5	55	input	Receive code group bit 5 (Ethernet 1)
NET1_RX_D2	56	input	Receive code group bit 2 (Ethernet 1)
NET1_RX_D6	59	input	Receive code group bit 6 (Ethernet 1)
NET1_RX_D0	60	input	Receive code group bit 0 (Ethernet 1)
NET1_RX_D3	61	input	Receive code group bit 3 (Ethernet 1)
NET1_RX_D4	62	Input	Receive code group bit 4 (Ethernet 1)
NET1_RX_COL	65	input	GMII and MII Collision pin (Ethernet 1)
NET1_RX_DV	66	input	Receive data valid pin (Ethernet 1)
NET1_LED_LINK1000	67	input	Parallel LED output for link indicator (Ethernet 1)
NET1_RX_CLK	68	input	Receive Clock provides a clock reference (Ethernet 1)
NET1_TX_D1	71	output	Transmit code group bit 1 (Ethernet 1)
NET1_TX_CLK	72	input	Provides a clock reference (Ethernet 1)
NET1_TX_D5	73	output	Transmit code group bit 5 (Ethernet 1)
NET1_RX_ER	74	input	Receive Error pin (Ethernet 1)
NET1_TX_ER	77	output	Transmit Error Pin (Ethernet 1)
NET1_TX_D6	78	output	Transmit code group bit 6 (Ethernet 1)
NET1_TX_EN	79	output	Transmit Enable (Ethernet 1)
NET1_TX_D7	80	output	Transmit code group bit 7 (Ethernet 1)
NET1_TX_D0	83	output	Transmit code group bit 0 (Ethernet 1)
NET1_RESETh	84	output	Hardware reset active low (Ethernet 1)
NET1_TX_D4	85	output	Transmit code group bit 4 (Ethernet 1)
NET1_MDC	86	output	Management data clock reference (Ethernet 1)
NET1_MDIO	89	inout	Management data pin (Ethernet 1)
NET1_TX_D2	90	output	Transmit code group bit 2 (Ethernet 1)
NET1_INTn	91	output	Polarity pin (Ethernet 1)
NET1_TX_D3	92	output	Transmit code group bit 3 (Ethernet 1)
NET1_GTX_CLK	95	output	Transmit Clock (Ethernet 1)

NET0_S_CLKp	96	input	SGMII 625 MHz positive receive clock (Ethernet 0)
NET0_GTX_CLK	97	output	Transmit Clock (Ethernet 0)
NET0_S_CLKn	98	input	SGMII 625 MHz negative receive clock (Ethernet 0)
NET0_RX_D2	101	input	Receive code group bit 2 (Ethernet 0)
NET0_LED_LINK1000	102	input	Parallel LED output for link indicator (Ethernet 0)
NET0_RX_D0	103	input	Receive code group bit 0 (Ethernet 0)
NET0_RX_CRS	104	input	Carrier Sense pin (Ethernet 0)
NET0_RX_DV	107	input	Receive data valid pin (Ethernet 0)
NET0_RX_D7	108	input	Receive code group bit 7 (Ethernet 0)
NET0_TX_D5	109	output	Transmit code group bit 5 (Ethernet 0)
NET0_RX_D4	110	input	Receive code group bit 4 (Ethernet 0)
NET0_TX_D7	113	output	Transmit code group bit 7 (Ethernet 0)
NET0_RX_COL	114	input	GMII and MII Collision pin (Ethernet 0)
NET0_RX_ER	115	input	Receive Error pin (Ethernet 0)
NET0_RX_D6	116	input	Receive code group bit 6 (Ethernet 0)
NET0_TX_ER	119	output	Transmit Error Pin (Ethernet 0)
NET0_RX_D5	120	input	Receive code group bit 5 (Ethernet 0)
NET0_TX_EN	121	output	Transmit Enable (Ethernet 0)
NET0_RX_D3	122	input	Receive code group bit 3 (Ethernet 0)
NET0_TX_D0	125	output	Transmit code group bit 0 (Ethernet 0)
NET0_RX_D1	126	input	Receive code group bit 1 (Ethernet 0)
NET0_TX_D4	127	output	Transmit code group bit 4 (Ethernet 0)
NET0_RX_CLK	128	input	Receive Clock provides a clock reference (Ethernet 0)
NET0_TX_D6	131	output	Transmit code group bit 6 (Ethernet 0)
NET0_TX_CLK	132	input	Provides a clock reference (Ethernet 0)
NET0_MDIO	133	inout	Management data pin (Ethernet 0)
NET0_TX_D1	134	output	Transmit code group bit 1 (Ethernet 0)
NET0_MDC	137	output	Management data clock reference (Ethernet 0)
NET0_TX_D2	138	output	Transmit code group bit 2 (Ethernet 0)
NET0_INTn	139	output	Polarity pin (Ethernet 0)
NET0_TX_D3	140	output	Transmit code group bit 3 (Ethernet 0)
NET0_RESETn	146	output	Hardware reset active low (Ethernet 0)
NET0_S_RX_p	149	input	SGMII receive data positive (Ethernet 0)
NET0_S_RX_n	151	input	SGMII receive data negative (Ethernet 0)
NET0_S_TX_p	155	output	SGMII transmit data positive (Ethernet 0)
NET1_S_CLKp	156	input	SGMII 625 MHz positive receive clock

			(Ethernet 1)
NET0_S_TX_n	157	output	SGMII transmit data negative (Ethernet 0)
NET1_S_CLKn	158	input	SGMII 625 MHz negative receive clock (Ethernet 1)

3.2 I2C Serial EEPROM

■ This section describes the I2C Serial EEPROM on the HSMC-NET board

The HSMC-NET board provides an EEPROM (U1) which is configured by the I2C interface. The size of the EEPROM is 2K-bit which can store MAC information or user’s data. The Default I2C slave address is ‘0xA0’. The detailed pin description between the HSMC connector and EEPROM is shown below in **Figure 3-2**.

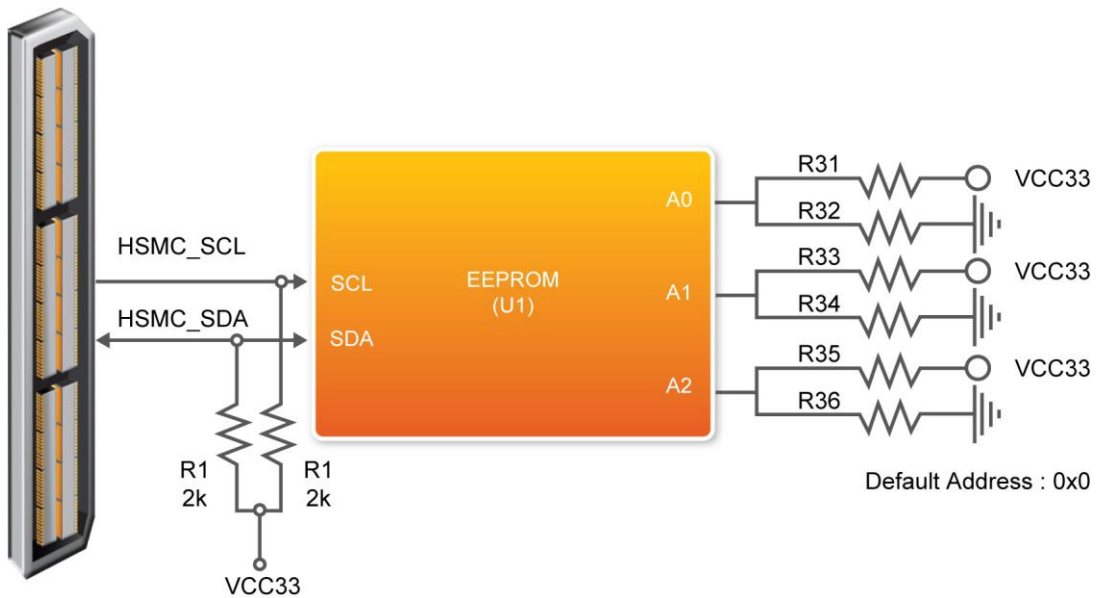

Figure 3-2 The block diagram of the EEPROM and HSMC connector

Table 3-2 The pin assignments of the EEPROM (U1)

Table 3.2 The pin assignments of the EEPROM (U1)			
EEPROM Pin	EEPROM Signal	HSMC Pin	HSMC Signal Name
Number	Name	Number	
5	HSMC_SDA	33	HSMC_SDA
6	HSMC_SCL	34	HSMC_SCL

Chapter 4

Demonstrations

This chapter illustrates how to build a simple socket server created in Nios II

4.1 Introduction

- **This section describes the functionality of the demonstration briefly.**

In this demonstration, we use DE3 as the host board connected to the HSMC-NET daughter board. However, the HSMC-NET and Cyclone III FPGA Starter Kit Demo is also available in the HSMC-NET CD-ROM.

We will illustrate how to create a simple socket server generated in Nios II using the Ethernet daughter board with the DE3 host board. As indicated in the block diagram in **Figure 4-1**, the Nios II processor is used to communicate with the Client via 88E1111 Ethernet Device.

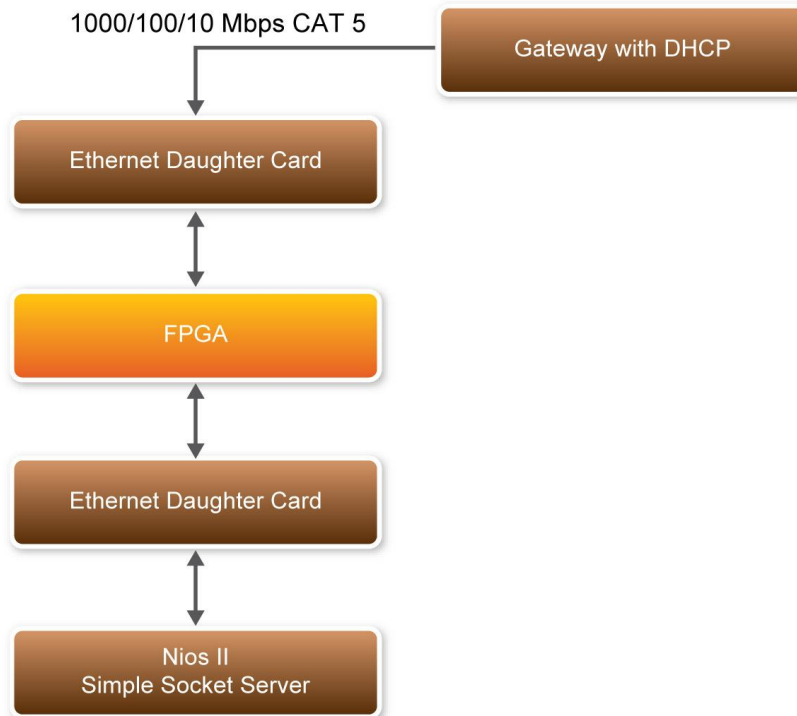

Figure 4-1 Block diagram of demonstration

As Part of the Nios II, NicheStack TCP/IP Network Stack is a software suite of networking protocols designed to provide an optimal solution for designing network-connected embedded devices with the Nios II processor. A telnet client application is used to communicate with the simple socket server issuing commands over a TCP/IP socket to the Ethernet-connected NicheStack TCP/IP Stack running Nios II on the DE3 host board with a simple socket server. The Simple Socket Server continues to listen for commands on a TCP/IP port and operates the DE3 LEDs according to the commands from the telnet client.

NicheStack TCP/IP stack uses the MicroC/OS-II RTOS multithreaded environment to provide immediate access to a stack for Ethernet connectivity for the Nios II processor. The Nios II processor system contains an Ethernet interface, or media access control (MAC).

4.2 How the Demonstration is built

The section describes the steps using Quartus II, Nios II, and SOPC builder in generating the demonstration.

The demonstration is setup using the DE3 System builder (v1.4.2) by configuring the DE3 I/O components and also building a connection between DE3 and HSMC-NET. In DE3 configuration we enabled the IO HSTC connector Group C to connect to the HSMC-NET shown in [Figure 4-2](#). Also, we want to enable the IO Group B connector to use the DDR2 SO-DIMM, in addition enabling LED, Seg7 and Button which are used in the demonstration.

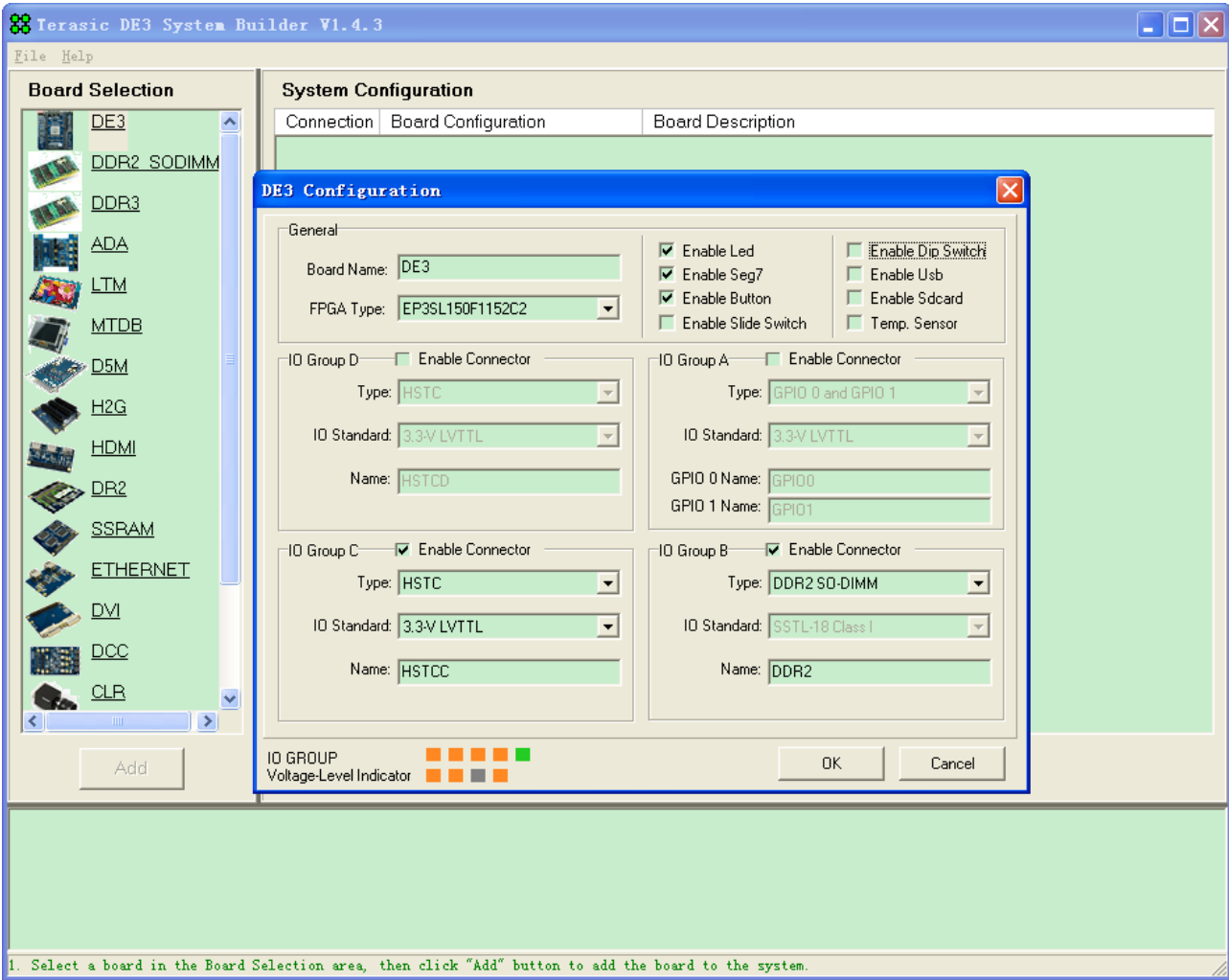

Figure 4-2 System Builder DE3 Configuration

Next we want to add the Ethernet board to our system builder and establish a connection with the DE3 board shown in **Figure 4-3**. The I/O standard voltage for the HSMC-NET daughter board is 2.5V. Once the connection is established between DE3 board and HSMC-NET board, the DE3 System builder will change the I/O standard of the connector to fit with the daughter board automatically. The I/O standard of the HSTCC male connector has been changed from 3.3-V LVTTTL to 2.5V. Also, the DDR2_SODIMM component is added in the board list by building a connection with the DE3 board.

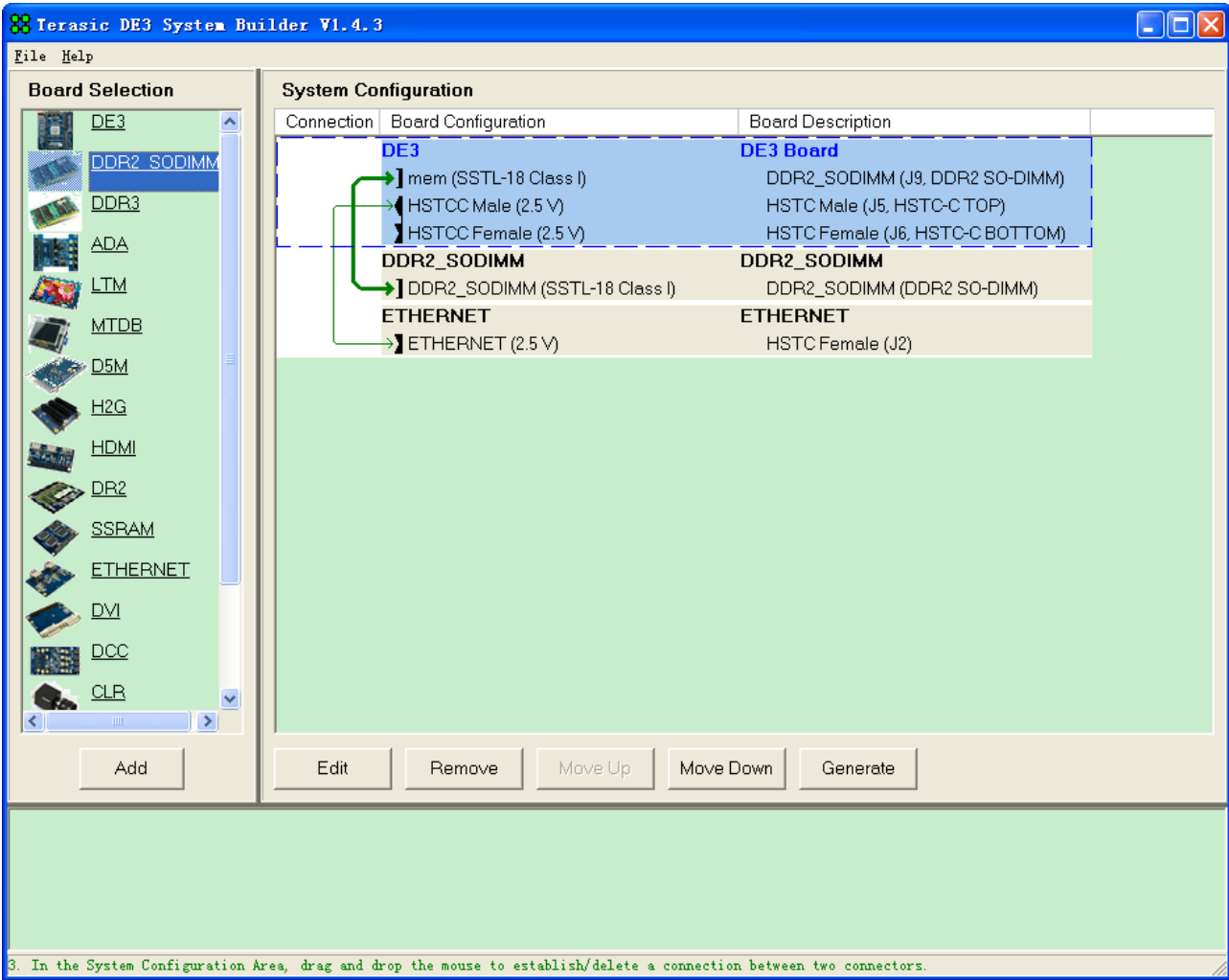

Figure 4-3 Note: A 2.5V standard voltage must be used for the HSMC-NET daughter board)

The following step we use the SOPC builder to create our SOPC. The SOPC includes the CPU processor, On-Chip memory, DDR2 controller, JTAG UART, system ID, timer, Triple-Speed Ethernet, Scatter-Gather DMA controller and peripherals which are linked together contained in the Nios II hardware system that are used when building a project.

In the Triple-Speed Ethernet IP Core configuration, the interface is set to GMII interface as well as using the internal FIFO shown in [Figure 4-4](#).

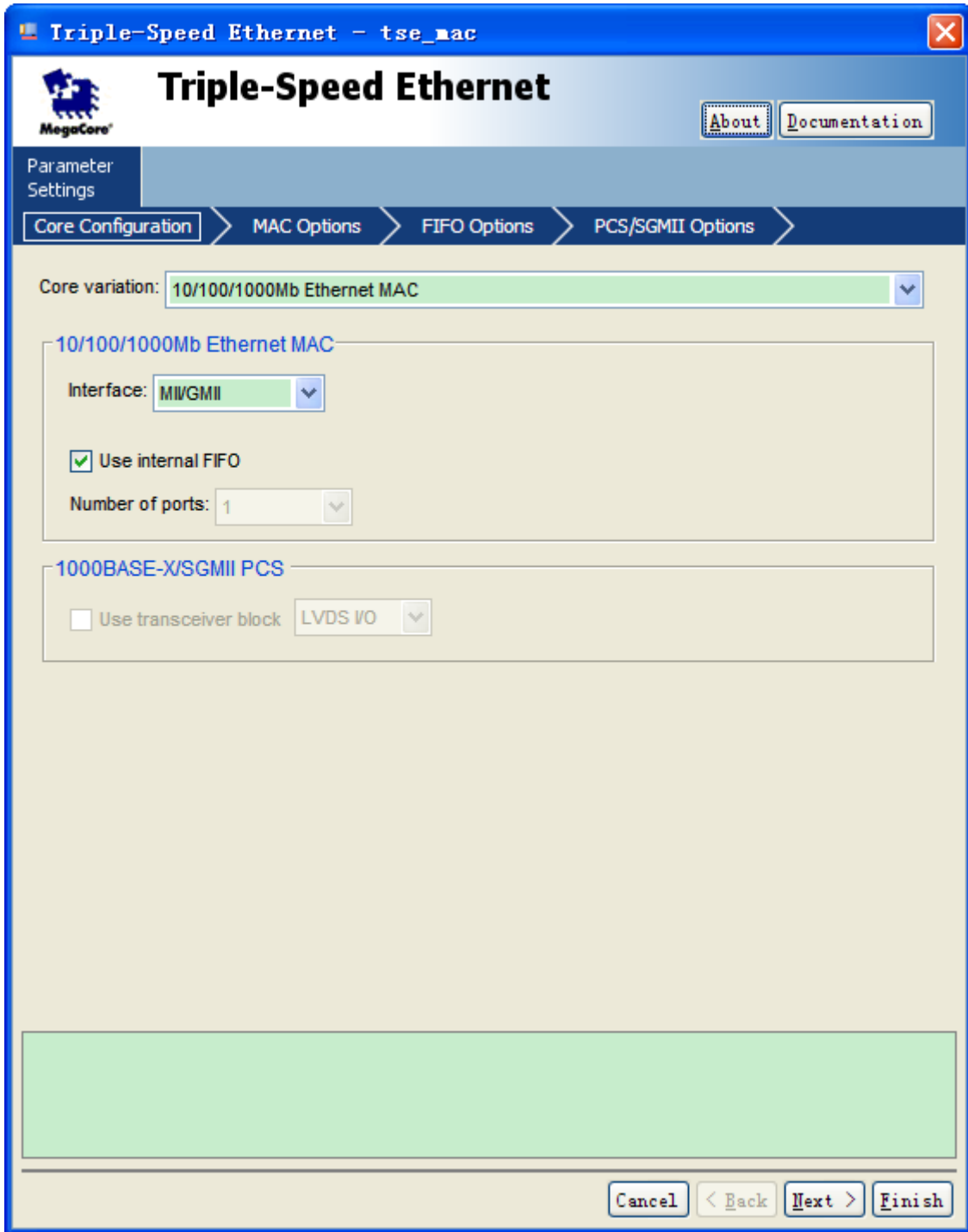

Figure 4-4 Triple-Speed Ethernet Core Configuration

In the Mac Options section, the MDIO module is included that controls the PHY Management Module associated with the MAC block shown in [Figure 4-5](#). The host Clock divisor is to divide the MAC control register interface clock to produce the MDC clock output on the MDIO interface. The MAC control register interface clock frequency is 100 MHz and the desired MDC clock frequency is 2.5 MHz, a host clock divisor of 40 should be used.

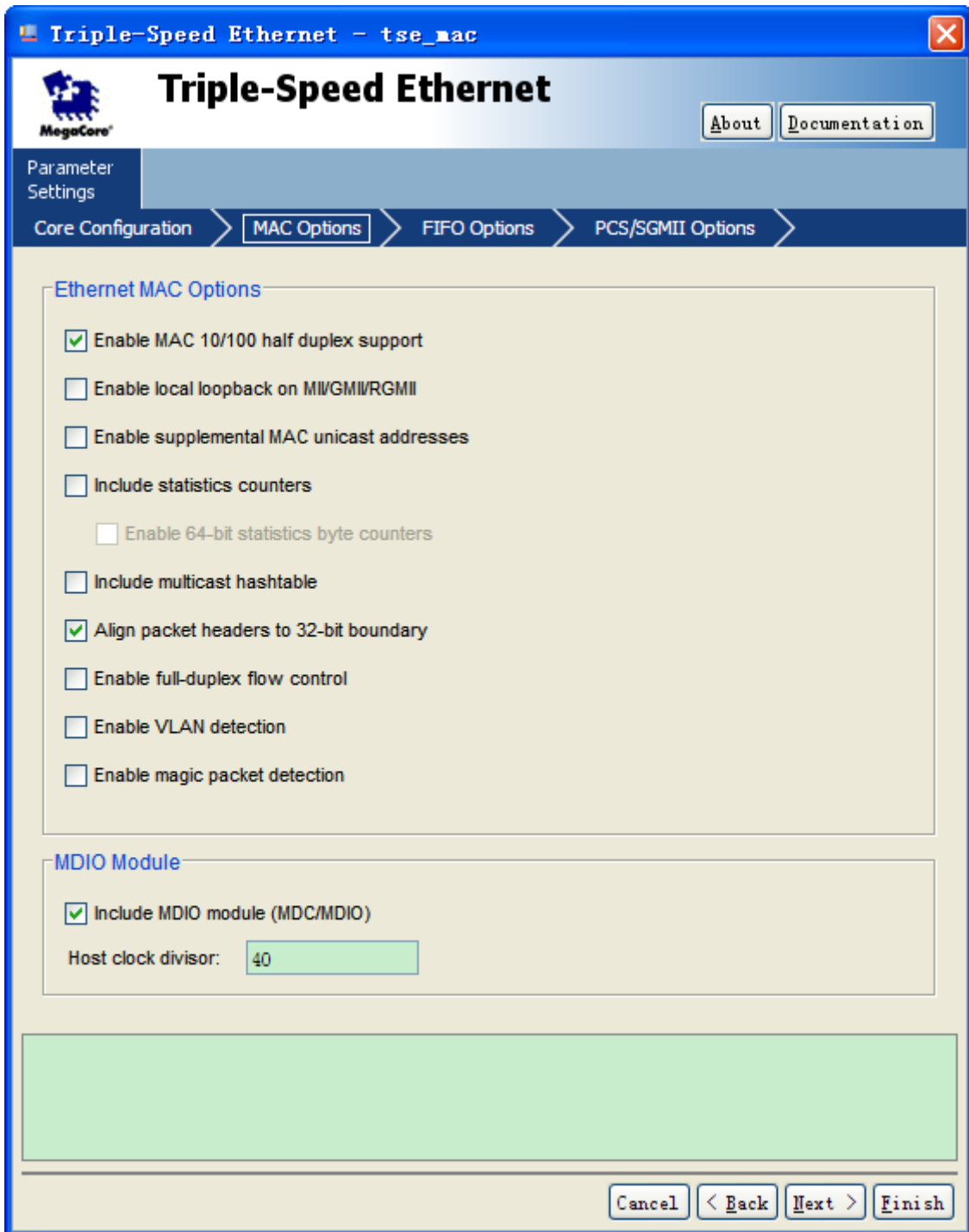

Figure 4-5 Triple-Speed Ethernet MAC Options

Once the Triple-Speed Ethernet IP configuration has been set and necessary hardware connections has been made shown in [Figure 4-6](#) click on generate.

Use	Connections	Module Name	Description	Clock	Base	Er
<input checked="" type="checkbox"/>		pio_button s1	PIO (Parallel IO) Avalon Memory Mapped Slave	pll_c0_peripheral	0x00000060	0xC
<input checked="" type="checkbox"/>		pio_dip_sw s1	PIO (Parallel IO) Avalon Memory Mapped Slave	pll_c0_peripheral	0x00000080	0xC
<input checked="" type="checkbox"/>		pio_sw s1	PIO (Parallel IO) Avalon Memory Mapped Slave	pll_c0_peripheral	0x00000090	0xC
<input checked="" type="checkbox"/>		tse_mac	Triple-Speed Ethernet			
		transmit	Avalon Streaming Sink	pll_c2_sys		
		receive	Avalon Streaming Source	pll_c2_sys		
		control_port	Avalon Memory Mapped Slave	pll_c2_sys	0x11023000	0x1
<input checked="" type="checkbox"/>		sgdma_tx	Scatter-Gather DMA Controller			
		csr	Avalon Memory Mapped Slave	pll_c2_sys	0x11023400	0x1
		descriptor_read	Avalon Memory Mapped Master			
		descriptor_write	Avalon Memory Mapped Master			
		m_read	Avalon Memory Mapped Master			
		out	Avalon Streaming Source			
<input checked="" type="checkbox"/>		sgdma_rx	Scatter-Gather DMA Controller			
		csr	Avalon Memory Mapped Slave	pll_c2_sys	0x11023440	0x1
		descriptor_read	Avalon Memory Mapped Master			
		descriptor_write	Avalon Memory Mapped Master			
		m_write	Avalon Memory Mapped Master			
		in	Avalon Streaming Sink			
<input checked="" type="checkbox"/>		descriptor_memory s1	On-Chip Memory (RAM or ROM) Avalon Memory Mapped Slave	pll_c2_sys	0x11020000	0x1

Figure 4-6 SOPC builder

The Block diagram shows the connection for programmable 10/100/1000 Ethernet operation via GMII

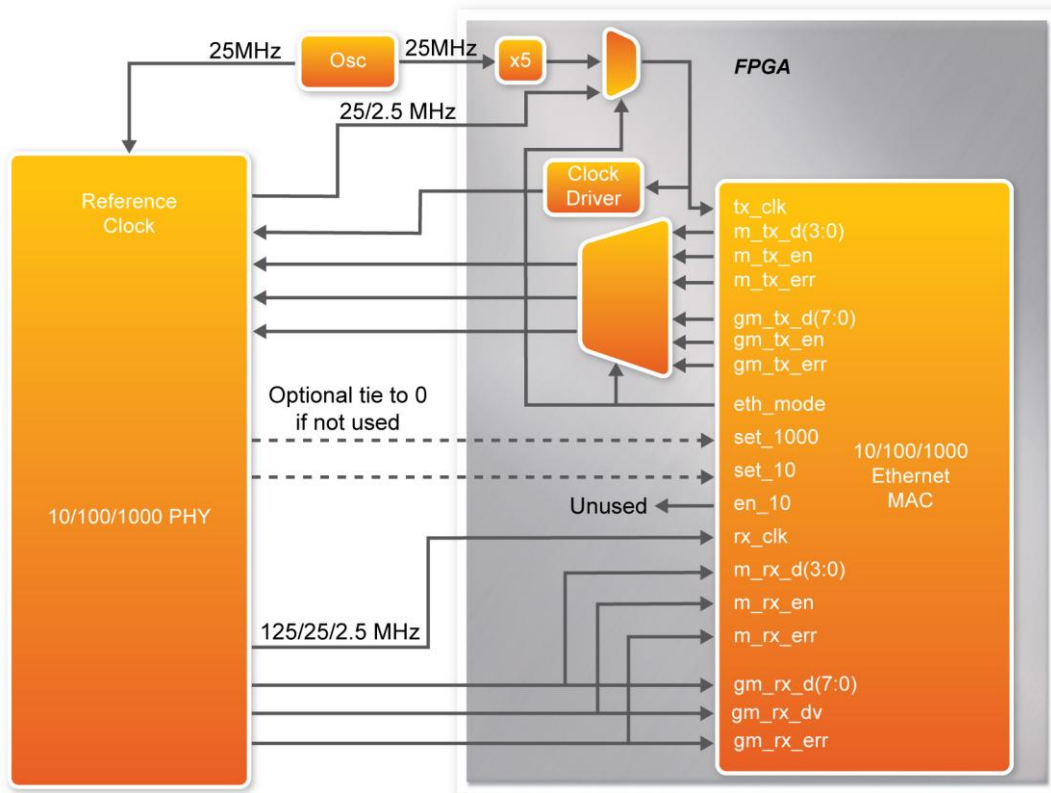

Figure 4-7 shows how gigabit Ethernet PHYs are connected to the MAC via GMII

In this next section describes the steps to create the Simple Socket Server using Nios II. We create a new project in Nios II using the project template, Simple Socket Server. The PTF file created using the SOPC builder in Quartus II is used in the Select Target Hardware section.

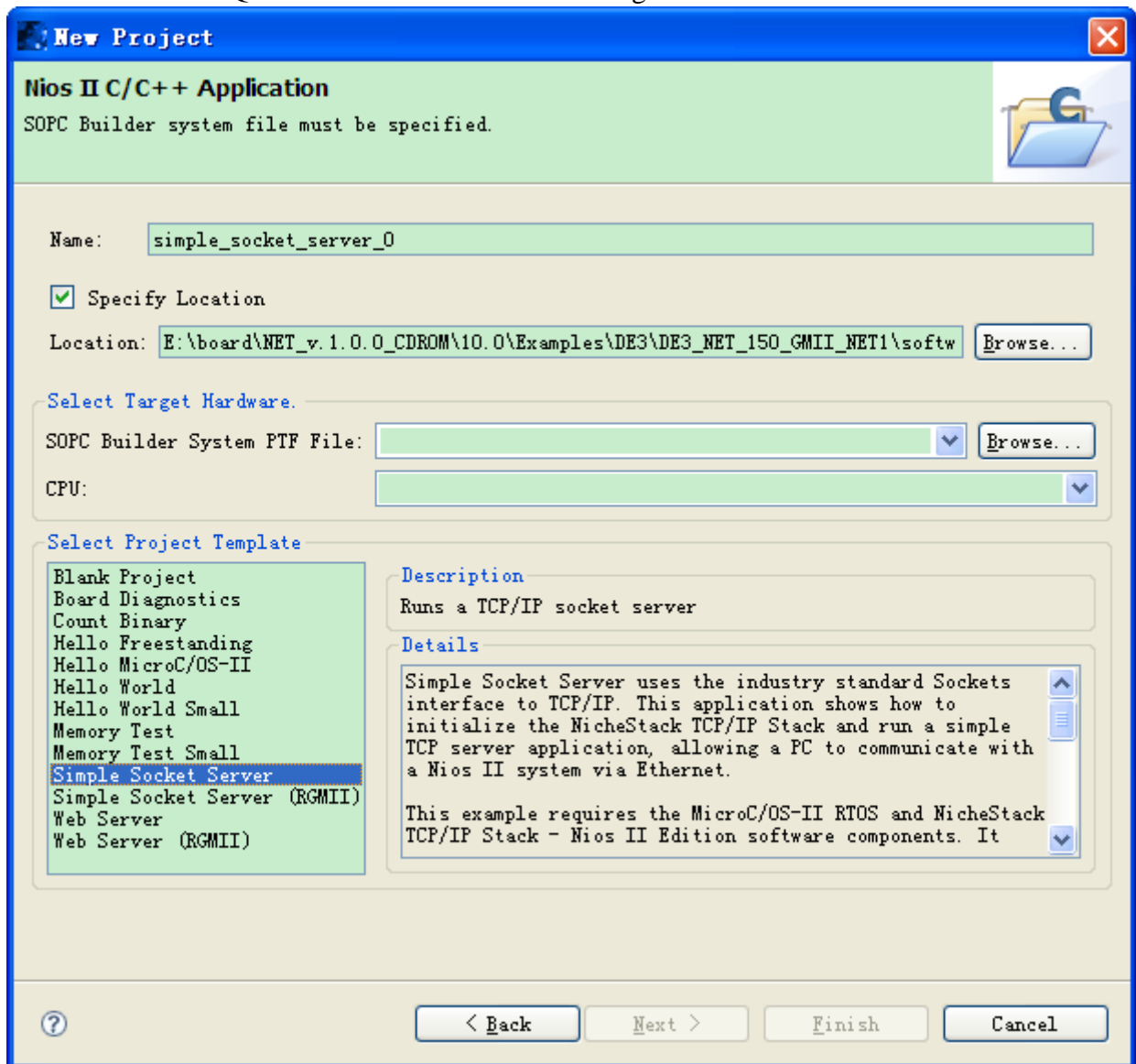

Figure 4-8 Nios II Project Simple Socket Server

After the project is created, open network_utilities.c to modify the flash section which uses flash to store the MAC address. Since the demonstration uses DE3 host board which doesn't have flash memory, the flash portion of the code can be commented out shown in Figure 4-9 as well as inserting our own Mac Address.

```

* valid network settings are present, indicated by a signature of 0x00005afe at
* the first address of the last flash sector. This hex value is chosen as the
* signature since it looks like the english word "SAFE", meaning that it is
* safe to use these network address values.
*/

if (!error)
{
    signature = IORD_32DIRECT(last_flash_sector, 0);
    if (signature != 0x00005afe)
    {
        error = generate_and_store_mac_addr();
    }
}

mac_addr[0] = 0x00;
mac_addr[1] = 0x07;
mac_addr[2] = 0xed;
mac_addr[3] = 0x12;
mac_addr[4] = 0x8f;
mac_addr[5] = 0xff;

if (!error)
{
    mac_addr[0] = IORD_8DIRECT(last_flash_sector, 4);
    mac_addr[1] = IORD_8DIRECT(last_flash_sector, 5);
    mac_addr[2] = IORD_8DIRECT(last_flash_sector, 6);
    mac_addr[3] = IORD_8DIRECT(last_flash_sector, 7);
    mac_addr[4] = IORD_8DIRECT(last_flash_sector, 8);
    mac_addr[5] = IORD_8DIRECT(last_flash_sector, 9);

    printf("Your Ethernet MAC address is %02x:%02x:%02x:%02x:%02x\n",
           mac_addr[0],

```

Figure 4-9 network_utilities.c modified code

In the Simple Socket Server, it uses GMII mode interface which we have to modify in the [ins_tse_mac.c](#) code shown in [Figure 4-10](#).

Around [line 327](#), the code “[marvell_cfg_gmii\(tse\[iface\].mi.base\);](#)” is included in order for the Simple Socket Server to operate in GMII mode.

```

if(tse_hw->use_shared_fifo == 1) {
    IOWR_ALTERA_MULTI_CHAN_FIFO_SEC_FULL_THRESHOLD(tse_hw->tse_shared_fifo_rx_ctrl_base,tse_hw->tse_shared_fifo_rx_ctrl_base);
    IOWR_ALTERA_MULTI_CHAN_FIFO_ALMOST_FULL_THRESHOLD(tse_hw->tse_shared_fifo_rx_ctrl_base,((tse_hw->tse_shared_fifo_rx_ctrl_base) + 1));
}
else {
    /* Initialize MAC registers */
    IOWR_ALTERA_TSEMAC_FRM_LENGTH(tse[iface].mi.base, ALTERA_TSE_MAC_MAX_FRAME_LENGTH);
    IOWR_ALTERA_TSEMAC_RX_ALMOST_EMPTY(tse[iface].mi.base, 8);
    IOWR_ALTERA_TSEMAC_RX_ALMOST_FULL(tse[iface].mi.base, 8);
    IOWR_ALTERA_TSEMAC_TX_ALMOST_EMPTY(tse[iface].mi.base, 8);
    IOWR_ALTERA_TSEMAC_TX_ALMOST_FULL(tse[iface].mi.base, 3);
    IOWR_ALTERA_TSEMAC_TX_SECTION_EMPTY(tse[iface].mi.base, tse_hw->tse_tx_depth - 16); //1024/4;
    IOWR_ALTERA_TSEMAC_TX_SECTION_FULL(tse[iface].mi.base, 0); //32/4; // start transmit when there are 48 k
    IOWR_ALTERA_TSEMAC_RX_SECTION_EMPTY(tse[iface].mi.base, tse_hw->tse_rx_depth - 16); //4000/4;
    IOWR_ALTERA_TSEMAC_RX_SECTION_FULL(tse[iface].mi.base, 0);
}
//enable the gmii mode //added 2010-09-25
marvell_cfg_gmii(tse[iface].mi.base);
/* Enable TX shift 16 for removing two bytes from the start of all transmitted frames */
if((ETHHDR_BIAS !=0) && (ETHHDR_BIAS !=2)) {
    dprintf("[tse_mac_init] Error: Unsupported Ethernet Header Bias Value, %d\n",ETHHDR_BIAS);
    return ENP_PARAM;
}

if(ETHHDR_BIAS == 0) {
    alt_32 temp_reg;
}

```

Figure 4-10 `ins_tse_mac.c` modified code

4.3 System Requirements

■ The following items are required for the HSMC-NET Server demonstration.

- HSMC-NET
- DDR2 SO-DIMM (Bundled in the DE3)
- DE3 Board
- THCB-HFF adapter card (Not required for Cyclone III FPGA Starter Kit & HSMC-NET Demo)
- Standard Cat 5 UTP (unshielded twisted pair) cable
- Gateway Router
- USB-Blaster cable

4.4 Setup the Demonstration

Figure 4-11 shows how to setup hardware for the HSMC-NET Server demonstration.

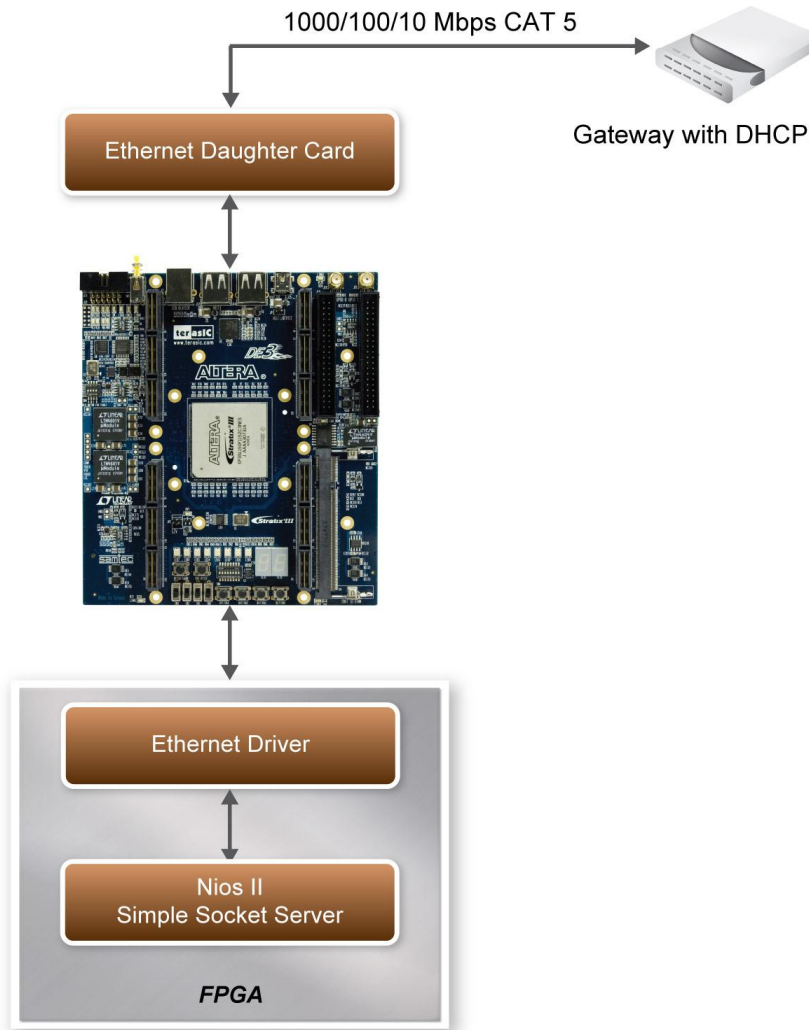

Figure 4-11 The hardware setup for the HSMC-NET server demonstration



Note: A THCB-HFF adapter card is used to establish connection with DE3 and HSMC-NET daughter board

4.5 Demo Operation

- This section describes the procedures of running the demonstration

FPGA Configuration

Demonstration Setup, File Locations, and Instructions

- Project directory: Demo_Batch
- Reminder: Select the appropriate DE3 Device Folder

- Bit Stream used: DE3_NET_DDR2.sof & simple_socket_server.elf
- Note: To compile the Quartus Project requires the Triple-Speed Ethernet License which can be obtained from Altera.
- Confirm the THCB-HFF adaptor is connected to the DE3 HSTC connector before connecting the HSMC-NET daughter board
- Power on the DE3 board, with the USB cable connected to the USB Blaster port as well as connecting the Ethernet Cable from the Gateway device to the Ethernet Transceiver
- Open the Simple Socket Server by executing the de3_net.bat file where the IP address and port number are assigned as shown below in **Figure 4-12**.

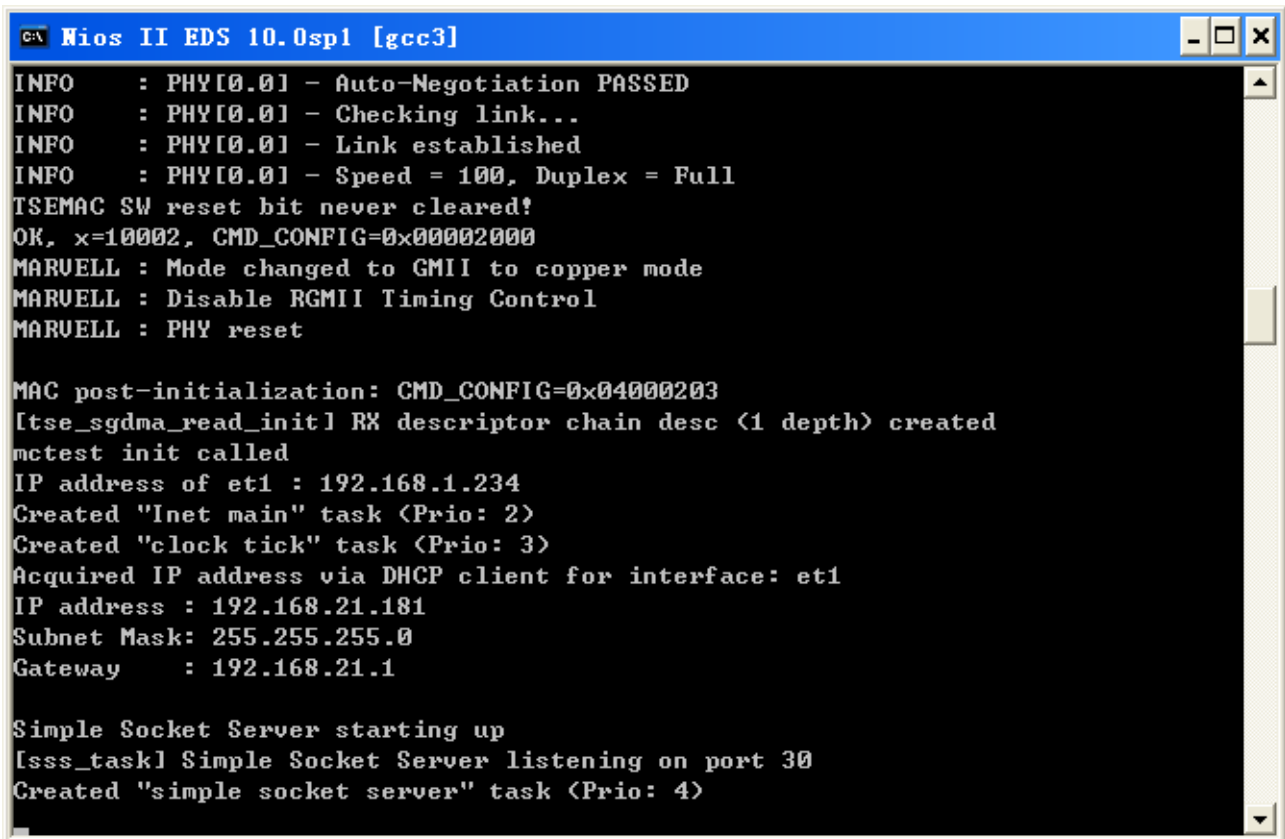

```

C:\ Nios II EDS 10.0spl [gcc3]
INFO      : PHY[0.0] - Auto-Negotiation PASSED
INFO      : PHY[0.0] - Checking link...
INFO      : PHY[0.0] - Link established
INFO      : PHY[0.0] - Speed = 1000, Duplex = Full
TSEMAC SW reset bit never cleared!
OK, x=10002, CMD_CONFIG=0x00002000
MARVELL  : Mode changed to GMII to copper mode
MARVELL  : Disable RGMII Timing Control
MARVELL  : PHY reset

MAC post-initialization: CMD_CONFIG=0x04000203
[ts_igdma_read_init] RX descriptor chain desc (1 depth) created
mctest init called
IP address of et1 : 192.168.1.234
Created "inet main" task (Prio: 2)
Created "clock tick" task (Prio: 3)
Acquired IP address via DHCP client for interface: et1
IP address : 192.168.21.181
Subnet Mask: 255.255.255.0
Gateway    : 192.168.21.1

Simple Socket Server starting up
[ss_task] Simple Socket Server listening on port 30
Created "simple socket server" task (Prio: 4)
  
```

Figure 4-12 Simple Socket Server

- To establish connection, start the telnet client session by executing open_telnet.bat file and include the IP address assigned by the DHCP server-provided IP along with the port number as shown below in **Figure 4-13**.

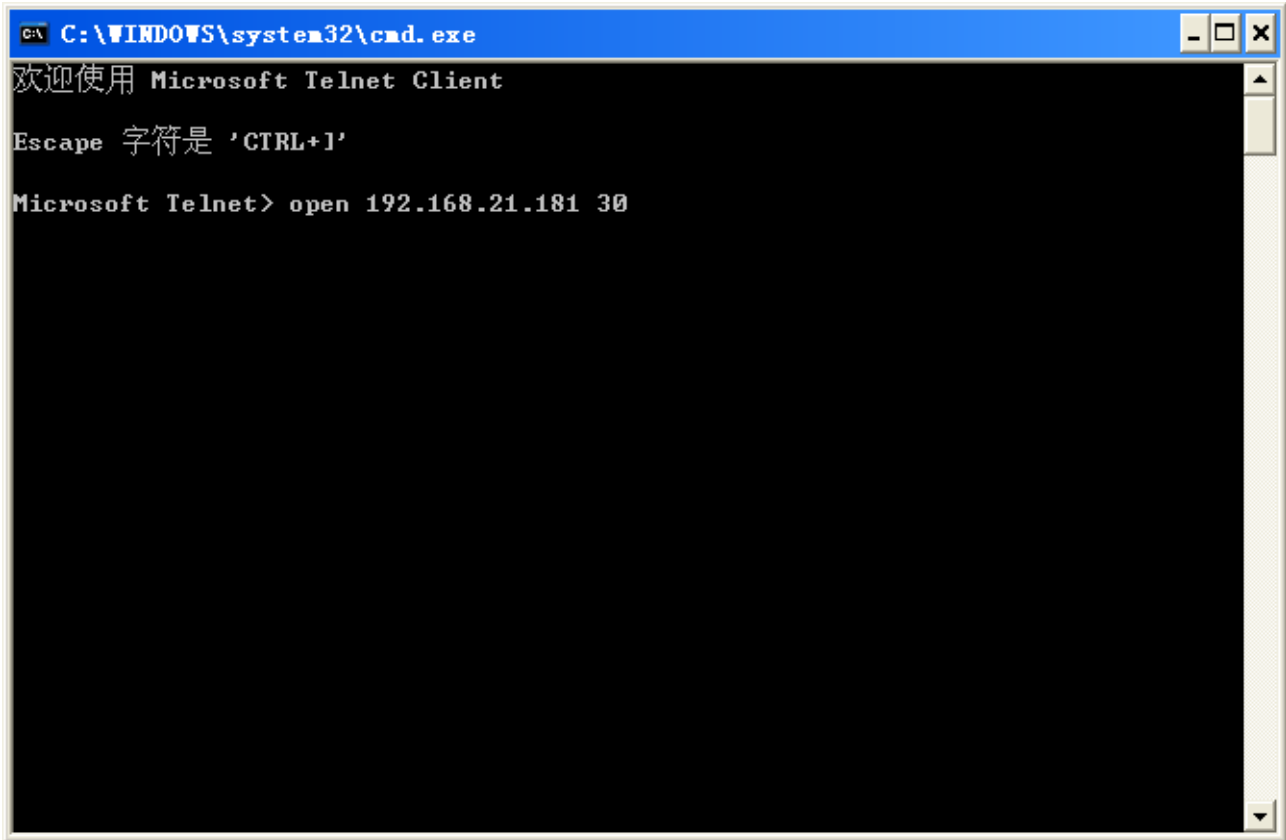

Figure 4-13 Telnet Client

- From the Simple Socket Server Menu, enter the commands in the telnet session. Start the session by initializing the seven-segment LED by entering the letter “s” followed by a return. Entering a number from zero through three, followed by a return, causes the corresponding LEDs (D0-D3) to toggle on or off on the DE3 host board.
- Observe the LED indications on the HSMC-NET daughter board showing what speed is connected, as well as the LEDs (D4-D7) blinking sequence is a lot faster connected to 1000Mbps compared to 100Mbps

4.6 Overview

- **This section describes the design concepts for the HSMC-NET demonstration.**

The Simple Socket Server uses the industry standard sockets interface to TCP/IP. It uses DHCP protocol to requests a valid IP from the Gateway. During the device initialization process, the NicheStack TCP/IP Stack system code calls `get_mac_addr()` and `get_ip_addr()` to set the MAC and IP addresses for the network interface.

Once MAC address is generated, Autonegotiation is initiated where both connected devices, the Ethernet (Marvel 88E1111) and Gateway devices broadcasts its transmission parameters, speed and duplex mode. By default, the MAC Interface for the Ethernet Device is set to RGMII. In this demonstration, we are using GMII MAC interface which can be configured through the management interface of the 88E1111 Ethernet device.

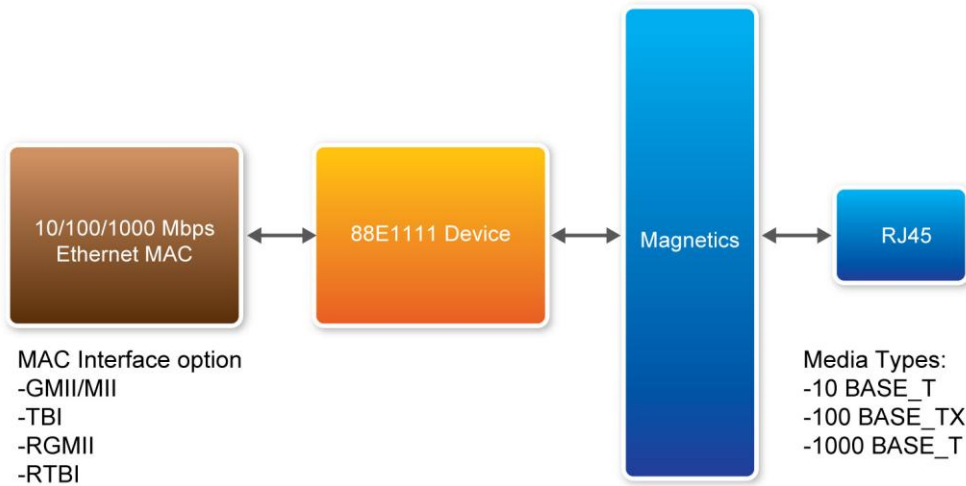

Figure 4-14 88EE111 Device Interface

Block Diagram in **Figure 4-14** shows the MAC interface options and supported media types for the HSMC-NET board. It supports copper media interface which is connected to an RJ-45 connector though magnetic supporting physical media for 1000BASE-T, 100BASE-TX, and 10BASE-T.

Once the link is established an IP address is assigned to the Ethernet device along with the port number. Through the TCP and port number, the demonstration uses Telnet client to establish connection with the Simple Socket Server, where it is continuously listening on the port. Once the connection is established between the Telnet client and Simple Socket server, the Telnet client is able to send packets which are received by the Nios II processor and through the Simple Socket Server it will send server command to the DE3. The packet sent contains LED command which is extracted and dispatched to the LED command queue for processing by the LED management tasks.

4.7 Nios Program

- This section describes the design flow and the Nios II software components

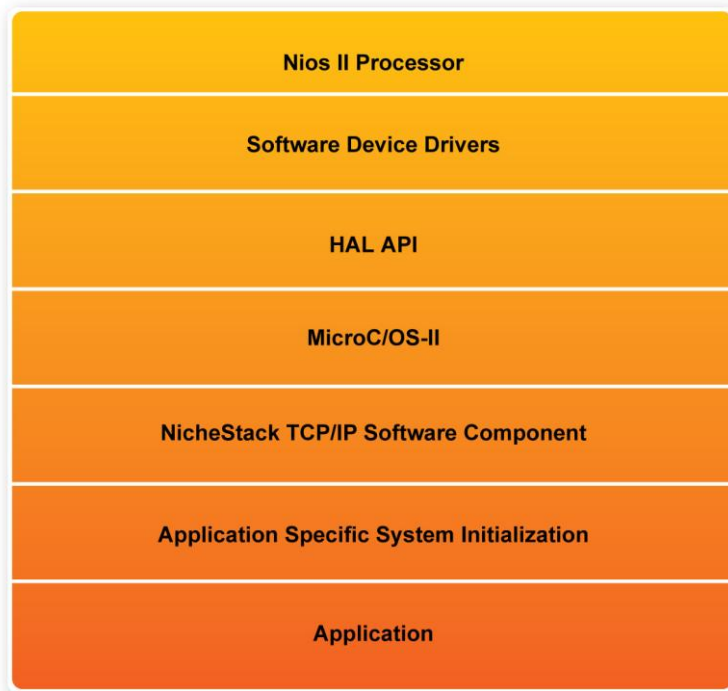

Figure 4-15 Nios Program Software Architecture

Figure 4-15 shows the software architecture of the Nios Program for the simple socket server. The top block containing the Nios II processor and the necessary hardware to be implemented into the DE3 host board. The software device drivers contain the necessary device drivers needed for the Ethernet and other hardware components to function. The HAL API block provides the interface for the software device drivers, while the MicroC/OS-II provides communication services to the NicheStack and the Simple Socket Server. The NicheStack TCP/IP Stack software block provides networking services to the application block where it contains the tasks for Simple Socket Server and also LED management.