



P_K_.0805.2ST._ Platinum thin film RTD

For the automatic assembling on PCBs

Benefits & Characteristics

- Excellent long-term stability and thermal cycling
- Low self-heating
- Automatic assembly in large-volume applications

Product image

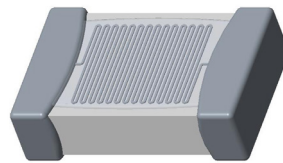

Illustration¹⁾

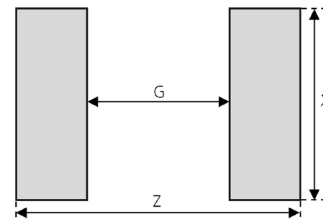
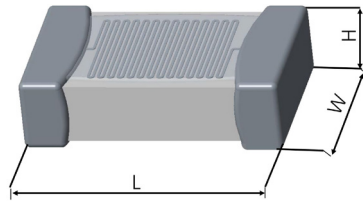

Dimensions

Dimensions in mm	L 2.0 ± 0.15	W 1.25 ± 0.15	H 0.5 ± 0.1
Land pattern in mm	Z 2.70	G 1.10	X 1.40

Technical Data

Electrical Specifications

Temperature range	-50 °C to +150 °C (see general notes 1.1)	
Nominal resistance	100 Ω at 0 °C, 500 Ω at 0 °C, 1000 Ω at 0 °C	
Characteristic	IEC 60751	
Tolerance class (dependent on temperature range)		IST AG reference
	IEC 60751 F0.15	A
	IEC 60751 F0.3	B
	IEC 60751 F0.6	C
Temperature coefficient	3850 ppm/K	
Temperature dependence of resistivity	according to IEC 60751:	
	-50 °C to 0 °C $R(T) = R_0 \times (1 + AxT + BxT^2 + Cx[T-100] \times T^3)$	
	0 to +150 °C $R(T) = R_0 \times (1 + AxT + BxT^2)$	
	A = 3.9083 × 10 ⁻³ × °C ⁻¹	
	B = -5.775 × 10 ⁻⁷ × °C ⁻²	
	C = -4.183 × 10 ⁻¹² × °C ⁻⁴	
	R ₀ = resistance value in Ω at 0°C	
	T = temperature in accordance with ITS90	



General Specifications

Pads (soldering connection)	Soft-Termination galvanic tin plated with nickel barrier layer		
Soldering (according to J-STD-002E) see general notes 1.3	1. Solderability: Test A and A1 2. Resistance to soldering heat: Test A and A1		
Measuring current (Self-heating has to be considered)	Pt 100 1 mA	Pt 500 0.5 mA	Pt 1000 0.3 mA
Long-term stability:	< 0.04 % at 1000 h at 130 °C		
Taping & Packaging	EIA-481 (for dimensions see general notes 1.2)		
Storage Property	12 months (original packaging and dry conditions)		
REACH + RoHs Compliance	Yes		
Special	Use in dry environment only		

General notes

- 1.1 The thermal coefficient of expansion of the circuit board has to be considered
- 1.2 Taping and Packaging:

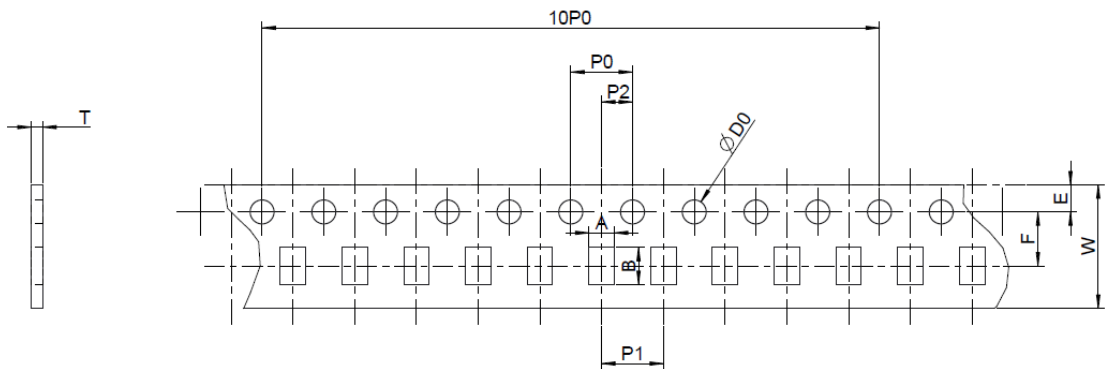

Item	A	B	W	E	F	P0	P1	P2	D0	T	10P0
Dimension	1.65	2.4	8.0	1.75	3.5	4.0	4.0	2.0	1.55	0.75	40.0
min. Tol.	-0.05	-0.05	-0.1	-0.05	-0.05	-0.1	-0.1	-0.05	-0.05	-0.03	-0.1
max. Tol.	0.05	0.05	0.1	0.05	0.05	0.1	0.1	0.05	0.05	0.03	0.1

Dimensions in mm.

Packaging unit in tape and reel, special variants, small quantities or other packaging unit are available on request.



1.3 Soldering and Reflow profile

For soldering IST AG recommends lead-free solder paste (Material: SnAgCu 96.5/3.0/0.5) and a temperature characteristic (reflow profile) for reflow soldering according to JEDEC J-STD-002E. The solderability was tested with following assembly conditions:

PCB Material: FR4 (PCB Layer: 2)
 PCB thickness: 1.6 mm
 Dimensions: 72 x 32 mm
 Solder Paste: KOKI „S3X58-M406“ (Pb-free assembly)

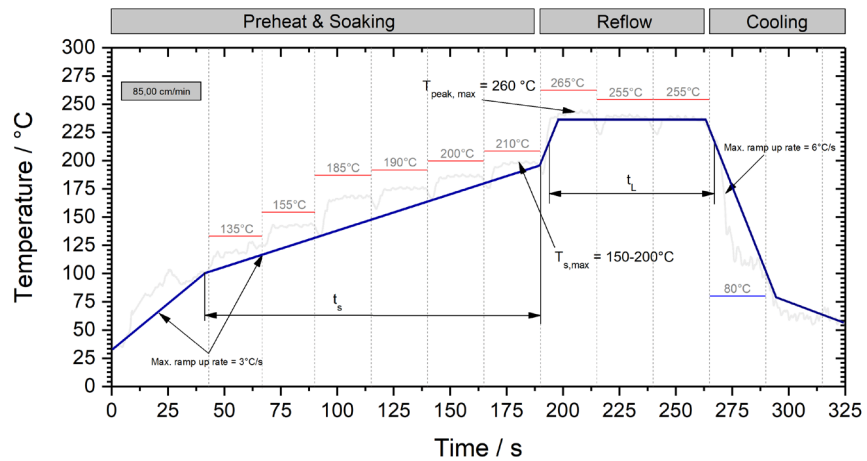

Profile parameter	Temperature range / °C	Heating rate / °C / s	Time / s
Ramp to preheat	RT to 150	1.9 - 3	
Preaheat /Soak	$T_{s,min} = 100, T_{s,max} = 200$	1.9 - 3	$t_{s,min} = 60, t_{s,max} = 160$
Ramp to Peak	180 - 255	0.6	
Reflow	$250 \pm 5, T_{peak,max} = 260$		60 to 120, $t_{peak,max} = 30$
Cooling	255 - RT	1.6 - 3	

1.4 Important notes:

- The solder or additional fluxes should be halogen-free, mild, and non-activated.
- After soldering, a thorough cleaning with pH-neutral defluxing material is recommended.
- The profile has a significant impact on the solder joint performance, i.e. solderability, wettability and strength.
- The soak profile and all other data serve as a guideline and cannot be regarded as binding statements or guaranteed values. They serve as a starting point for process development. Specifically, a high mix of components or large board sizes might require the development of a different soldering profile.
- Long-term stability in the application and chemical resistance need to be approved by the customer.
- The customer must test and approve the suitability of IST AG sensors in the customer's application.