

Single Channel Rotary Joints with N Connectors

305 & 344 Series, Coaxial In-Line, Type "N", Male and Female

Features

- **Average Power:** 500 watts at 1 GHz
- **Peak Power:** 10 kW
- Designed for MIL-E-5400 Class 2
- Type "N" Connectors
- High Reliability



APITech offers a full line of single channel rotary joints with N connectors. The 305 and 344 series rotary joints are designed for military and commercial markets and applications such as mobile satellite communication systems, radar systems including civil air traffic control and weather radars. These ultra reliable rotary joints are ideal for high speed operation and can be used up to 500 RPM (305 Series), or 1500 RPM (344 Series). APITech's line of rotary joints has been designed to MIL-E-5400 Class II.

APITech's 305 and 344 series rotary joints come standard with male and female N connectors, frequency coverage from DC - 12.4, and peak power at 10kW. APITech offers a line of standard catalog parts as well as custom options including a variety of connector types, orientation, mounting configurations, frequency optimization, testing requirements, and more.

Testing Specifications

Model Number	Part Number	Frequency DC-12.4 (GHz)	Insertion Loss (dB)	VSWR	VSWR Wow	Power at 1 GHz		Max DC Current (Amps)	Weight (Oz)	Torque (In-Oz)	Rotation Rate (RPM)
						Peak (KW)	Ave (W)				
305W	P1-5654G2	DC - 6	< 0.20	1.15:1	1.01	10	500	10	8	8	500
		6 - 10	< 0.25	1.30:1							
		10 - 12.4	< 0.30	1.50:1							
305WF	P1-5654G8	DC - 6	< 0.20	1.15:1	1.01	10	500	10	9	8	500
		6 - 10	< 0.25	1.30:1							
		10 - 12.4	< 0.30	1.50:1							
344	P1-5760G2	DC - 6	< 0.20	1.15:1	1.01	10	500	10	4	7	1500
		6 - 10	< 0.25	1.30:1							
		10 - 12.4	< 0.30	1.50:1							
344F	P1-5760G1	DC - 6	< 0.20	1.15:1	1.01	10	500	10	5	7	1500
		6 - 10	< 0.25	1.30:1							
		10 - 12.4	< 0.30	1.50:1							

NOTES:

¹ WOW (max. VSWR/min. VSWR) is 1.01 max per 360

Models designated F is flanged styles for gimbal

Single Channel Rotary Joints with N Connectors

305 & 344 Series, Coaxial In-Line, Type "N", Male and Female

Outline Drawings: 305 Series

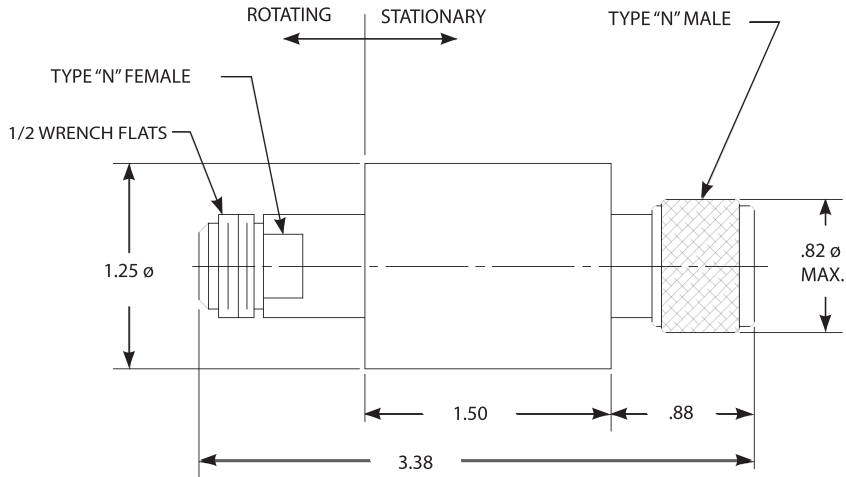

Model 305W

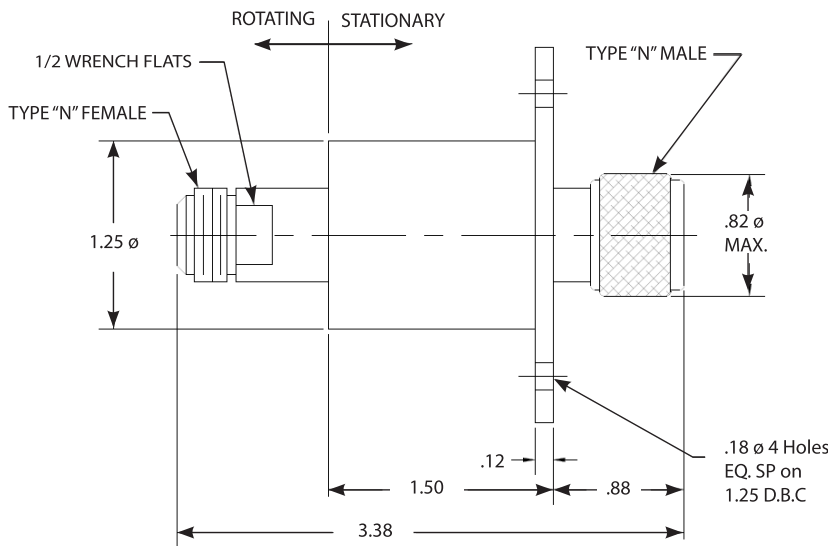

Model 305WF

All dimensions shown in decimal inches (mm). Specifications subject to change without notice.
 For mounting instructions, additional specifications or other products, visit us online or contact the factory.

Single Channel Rotary Joints with N Connectors

305 & 344 Series, Coaxial In-Line, Type "N", Male and Female

Outline Drawings: 344 Series

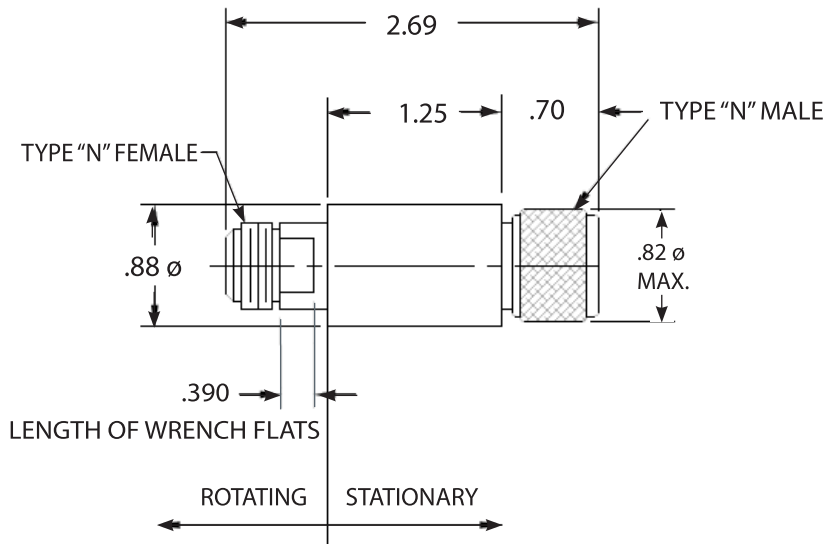

Model 344

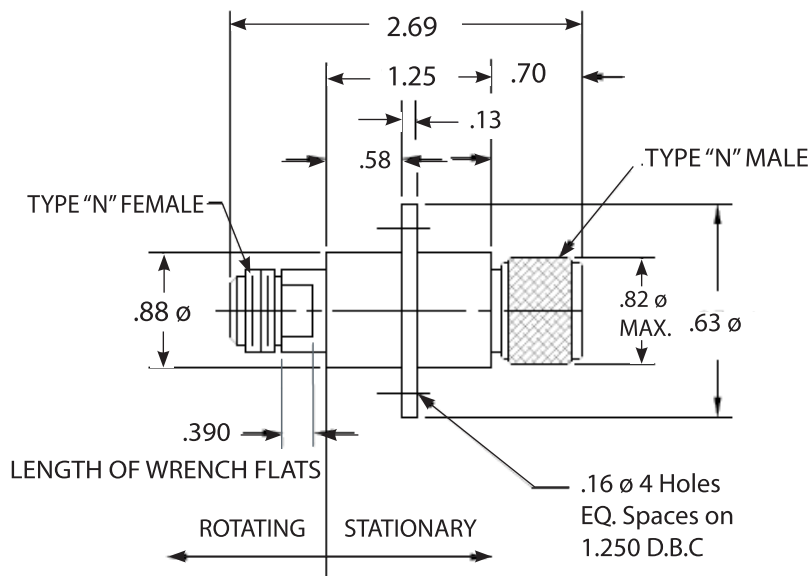

Model 344F

All dimensions shown in decimal inches (mm). Specifications subject to change without notice.
For mounting instructions, additional specifications or other products, visit us online or contact the factory.