

RPC-N
75 Ω

Airline Plug / Jack

P5S101-K150

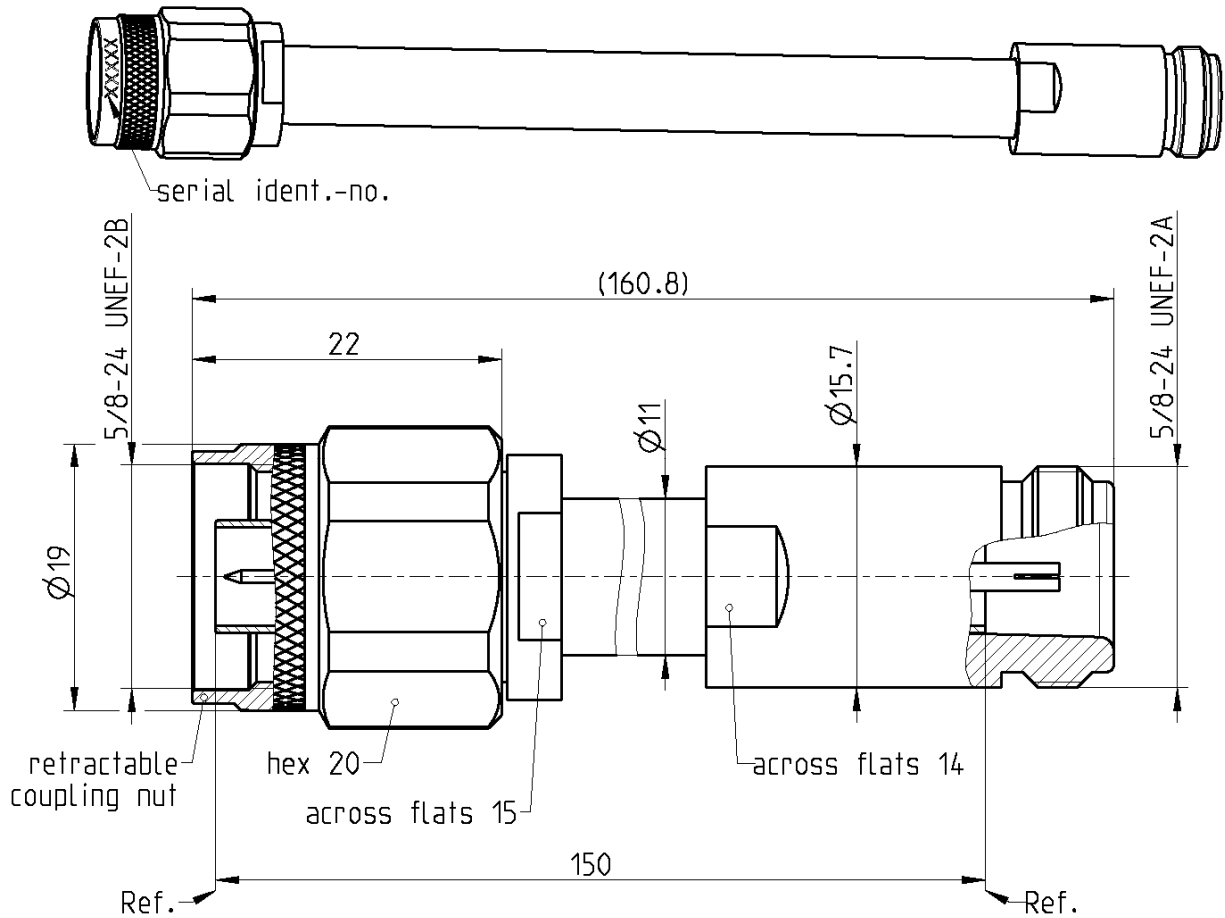

All dimensions are in mm; tolerances according to ISO 2768 m-H

Interface

According to IEC 61169-16

Documents

Application note AN001 "Calibration Services"

Material and plating

Connector parts

Center conductor
Outer conductor
Coupling nut

Material

CuBe
Brass
Stainless steel

Plating

Gold, min. 1.27 μm, over chemical nickel
Gold, min. 1.27 μm, over chemical nickel
Passivated

Dieses Dokument ist urheberrechtlich geschützt • This document is protected by copyright • Rosenberger Hochfrequenztechnik GmbH & Co. KG

RF_35/09;14/6.2

RPC-N
75 Ω

Airline Plug / Jack

P5S101-K150

Electrical data

Insertion loss ≤ 0.15 dB at 4 GHz

Mechanical data

Mating cycles ≥ 500
 Maximum torque 1.70 Nm
 Recommended torque 1.10 Nm
 Airline dimensions at 23 °C:
 - Diameter outer conductor 7.000 mm ± 0.005 mm
 - Diameter inner conductor 2.003 mm ± 0.005 mm
 - Length outer conductor 150.00 mm + 0.02 mm
 - Length inner conductor 150.00 mm - 0.02 mm
 - Length difference ≤ 0.04 mm
 (outer conductor – inner conductor)

Calculated data (non warranted)

Lossless characteristic impedance¹ 75 Ω ± 0.20 Ω
 Return loss² ≥ 40 dB, 0.3 GHz to 4 GHz

1. The lossless characteristic impedance is calculated from the specified diameters of the inner and outer conductor.
2. The return loss is calculated from the characteristic impedance, the skin depth and the connector interface.

General standard definitions

For proper work the vector network analyzer (VNA) used needs a model describing the electrical behaviour of this calibration standard. Depending on the VNA type different models, units and terms are used and have to be entered into the VNA. All values are based on typical geometry and plating.

- Offset Z_o / Impedance / Z_o 75 Ω
 - Offset Delay 500.542 ps
 - Length (electrical) / Offset Length 150.059 mm
 - Offset Loss 1.20 GΩ/s
 - Loss 0.0348 dB/√GHz

Environmental data

Operating temperature range³ +20 °C to +26 °C
 Storage temperature range 0 °C to +50 °C
 RoHS compliant

3. This range is a recommendation. However, the airline can be used in a wider range. Any temperature change from 23 °C results in dimensional changes.

Dieses Dokument ist urheberrechtlich geschützt • This document is protected by copyright • Rosenberger Hochfrequenztechnik GmbH & Co. KG

RF_35/09;14/6.2