

Power Operational Amplifiers

FEATURES

- High Power Bandwidth — 350 kHz
- Slew Rate — 20V/ μ s
- Fast Settling Time — 600ns
- Low Crossover Distortion — Class A/B
- Low internal Losses — 1.2V at 2A
- High Output Current — \pm 5A Peak
- Low Input Bias Current — FET Input
- Isolated Case — 300 VDC



APPLICATIONS

- Motor, Valve, and Actuator Control
- Magnetic Deflection Circuits up to 5A
- Power Transducers up to 350 kHz
- Audio Amplifiers up to 44W RMS

DESCRIPTION

The PA16 and PA16A are wideband, high output current operational amplifiers designed to drive resistive, inductive and capacitive loads. Their complementary “collector output” stage can swing close to the supply rails and is protected against inductive kickback. For optimum linearity, the output stage is biased for class A/B operation. The safe operating area (SOA) can be observed for all operating conditions by selection of user programmable, current limiting resistors (down to 10mA). Both amplifiers are internally compensated but are not recommended for use as unity gain followers. For continuous operation under load, mounting on a heat-sink of proper rating is recommended.

These hybrid integrated circuits utilize thick film (cermet) resistors, ceramic capacitors and semiconductor chips to maximize reliability, minimize size and give top performance. Ultrasonically bonded aluminum wires provide reliable interconnections at all operating temperatures. The Power SIP is electrically isolated.

Figure 1: Equivalent Schematic

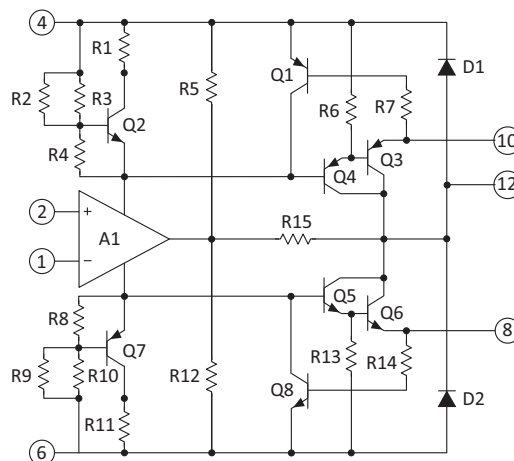

TYPICAL CONNECTION

Figure 2: Typical Connection

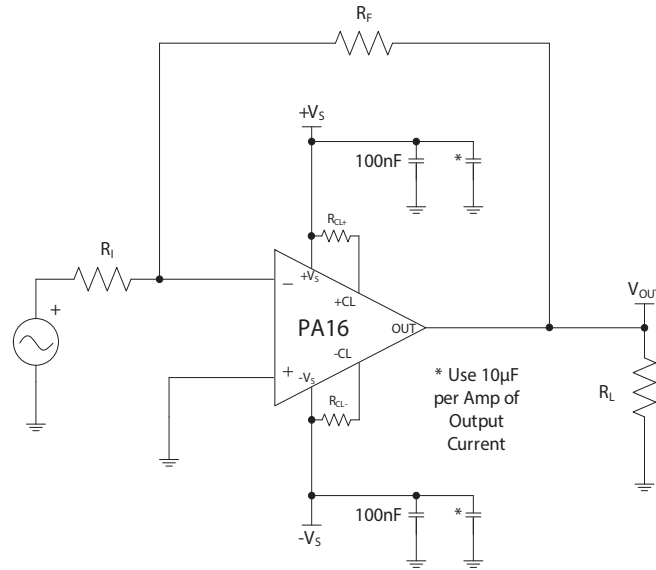

PINOUT AND DESCRIPTION TABLE

Figure 3: External Connections

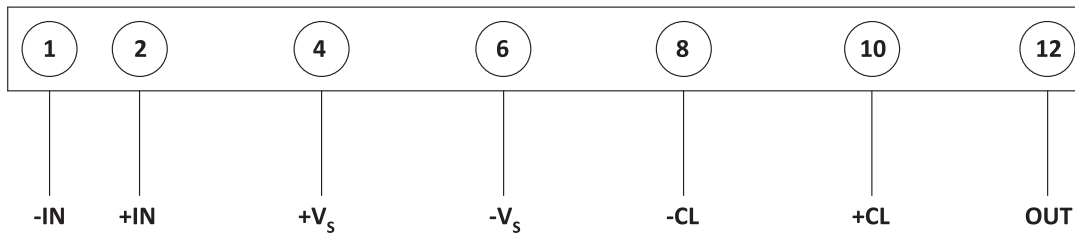

Pin Number	Name	Description
1	-IN	The inverting input.
2	+IN	The non-inverting input.
4	+Vs	The positive supply rail.
6	-Vs	The negative supply rail.
8	-CL	Connect to the sinking current limit resistor. Power supply current flows out of this pin through R _{CL-} . The negative supply is connected to the other side of R _{CL-} .
10	+CL	Connect to the sourcing current limit resistor. Power supply current flows into this pin through R _{CL+} . The positive supply is connected to the other side of R _{CL+} .
12	OUT	The output. Connect this pin to load and to the feedback resistors.
3, 5, 7, 9, 11	NC	No connection.

SPECIFICATIONS

All Min/Max characteristics and specifications are guaranteed over the Specified Operating Conditions. Typical performance characteristics and specifications are derived from measurements taken at typical supply voltages and $T_C = 25^\circ\text{C}$. The power supply voltage for all specifications is the TYP rating unless otherwise noted as a test condition. Full temperature specifications are guaranteed but not 100% tested.

ABSOLUTE MAXIMUM RATINGS

Parameter	Symbol	Min	Max	Units
Supply Voltage, total	$+V_S$ to $-V_S$		38	V
Output Current, within SOA	I_{OUT}		5	A
Power Dissipation, internal ¹	P_D		62.5	W
Input Voltage, differential	$V_{IN (Diff)}$	-30	30	V
Input Voltage, common mode	V_{CM}	$-V_S + 2$	$+V_S - 2$	V
Temperature, pin solder, 10s max.			260	$^\circ\text{C}$
Temperature, junction ¹	T_J		150	$^\circ\text{C}$
Temperature Range, storage		-55	+125	$^\circ\text{C}$
Operating Temperature Range, case	T_C	-40	+85	$^\circ\text{C}$

1. Long term operation at the maximum junction temperature will result in reduced product life. Derate power dissipation to achieve high MTTF.

CAUTION

The substrate contains beryllia (BeO). Do not crush, machine, or subject to temperatures in excess of 850°C to avoid generating toxic fumes.

INPUT

Parameter	Test Conditions	PA16			PA16A			Units
		Min	Typ	Max	Min	Typ	Max	
Offset Voltage, initial			±5	±10		±1	±3	mV
Offset Voltage vs. Temperature	Full temp range		±10	±50		*	±25	μV/°C
Offset Voltage vs. Supply			±10			*		μV/V
Offset Voltage vs. Power			±6			*		μV/W
Bias Current, initial			50	200		25	100	μA
Bias Current vs. Temperature				200			*	μA/°C
Bias Current vs. Supply			0.01			*		μA/V
Offset Current, initial			25	100		15	50	μA
Offset Current vs. Temperature				100			*	μA/°C
Input Impedance, DC			1000			*		GΩ
Input Capacitance			3			*		pF
Common Mode Voltage Range, pos. ¹	Full temp range	+V _S - 6	+V _S - 3		*	*		V
Common Mode Voltage Range, neg. ¹	Full temp range	-V _S + 6	-V _S + 5		*	*		V
Common Mode Rejection, DC	Full temp range	70	100		*	*		dB

1. Exceeding CMV range can cause the output to latch.

GAIN

Parameter	Test Conditions	PA16			PA16A			Units
		Min	Typ	Max	Min	Typ	Max	
Open Loop @ 10 Hz	1 kΩ load		103			*		dB
Open Loop @ 10 Hz	Full temp range, 10 kΩ load	86	100		*	*		dB
Gain Bandwidth Product @ 1 MHz	10 Ω load		4.5			*		MHz
Power Bandwidth	10 Ω load		350			*		kHz
Phase Margin	Full temp range, 10 Ω load		30			*		°

OUTPUT

Parameter	Test Conditions	PA16			PA16A			Units
		Min	Typ	Max	Min	Typ	Max	
Voltage Swing ¹	$I_{OUT} = 5A$, $R_{CL} = 0.08 \Omega$	$\pm V_S - 4$	$\pm V_S - 3$		$\pm V_S - 3$	*		V
Voltage Swing ¹	$I_{OUT} = 2A$	$\pm V_S - 2$	$\pm V_S - 1.2$		$\pm V_S - 1.2$	*		V
Current, peak		5			*			A
Settling Time to 0.1%	2V step		0.6			*		μs
Slew Rate		13	20		*	*		V/ μs
Capacitive Load	Full temp range, $A_V > 10$		SOA			*		
Harmonic Distortion	$P_O = 5W$, $F = 1$ kHz, $R_L = 4 \Omega$		0.028			*		%
Small Signal Rise/fall Time	$R_L = 10 \Omega$, $A_V = 1$		100			*		ns
Small Signal Overshoot	$R_L = 10 \Omega$, $A_V = 1$		10			*		%

1. $+V_S$ and $-V_S$ denote the positive and negative supply rail respectively. Total V_S is measured from $+V_S$ to $-V_S$.

POWER SUPPLY

Parameter	Test Conditions	PA16			PA16A			Units
		Min	Typ	Max	Min	Typ	Max	
Voltage	Full temp range	± 7	± 15	± 19	*	*	*	V
Current, quiescent			27	40		*	*	mA

THERMAL

Parameter	Test Conditions	PA16			PA16A			Units
		Min	Typ	Max	Min	Typ	Max	
Resistance, AC, junction to case ¹	$F > 60$ Hz		1.4	1.63		*	*	$^{\circ}C/W$
Resistance, DC, junction to case	$F < 60$ Hz		1.8	2.0		*	*	$^{\circ}C/W$
Resistance, junction to air			30			*		$^{\circ}C/W$
Temperature Range, case	Meets full range specs	-25		+85	*		*	$^{\circ}C$

1. Rating applies if the output current alternates between both output transistors at a rate faster than 60 Hz.

Note: *The specification of PA16A is identical to the specification for PA16 in applicable column to the left.

TYPICAL PERFORMANCE GRAPHS

Figure 4: Power Derating

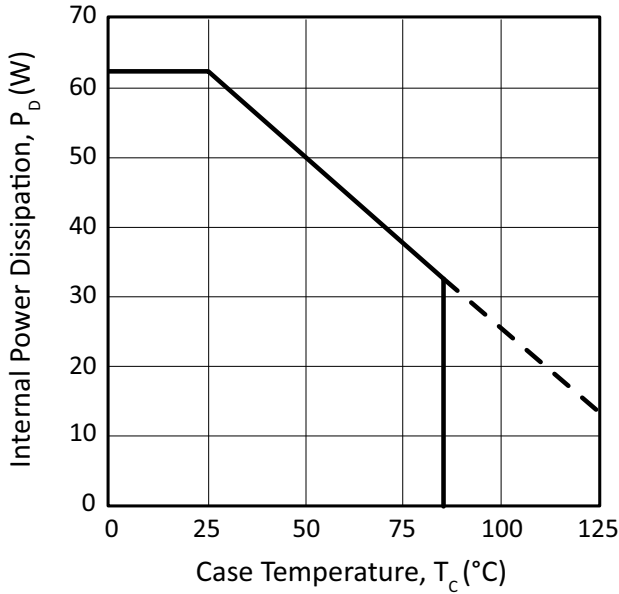

Figure 5: Output Voltage Swing

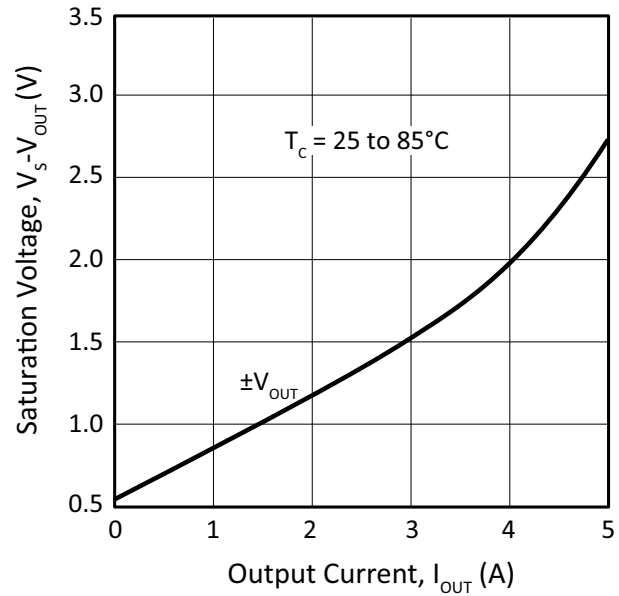

Figure 6: Small Signal Response

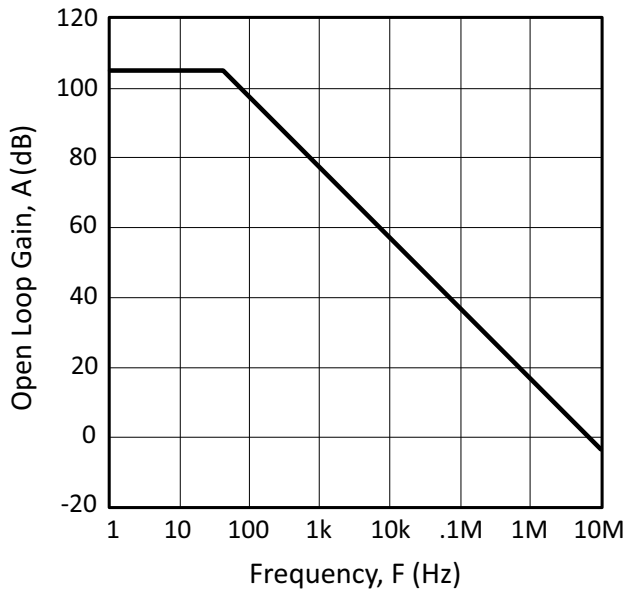

Figure 7: Phase Response

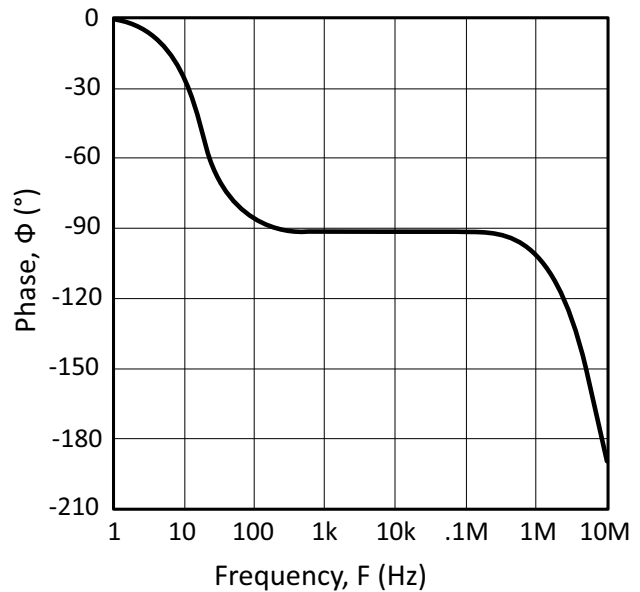

Figure 8: Current Limit

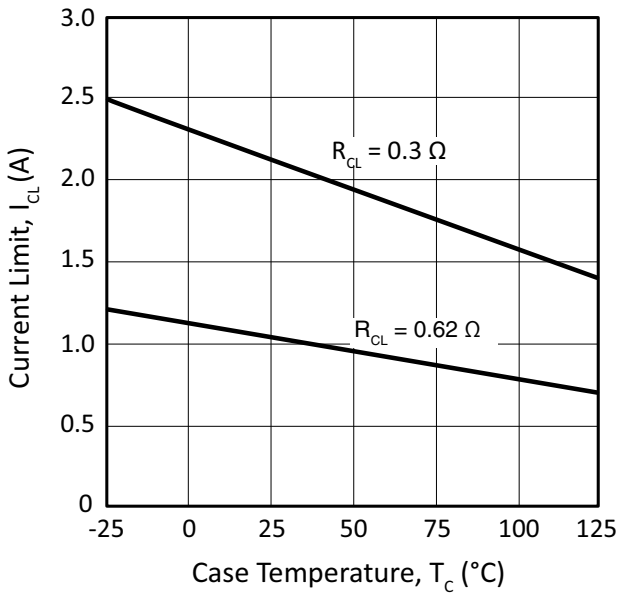

Figure 9: Power Response

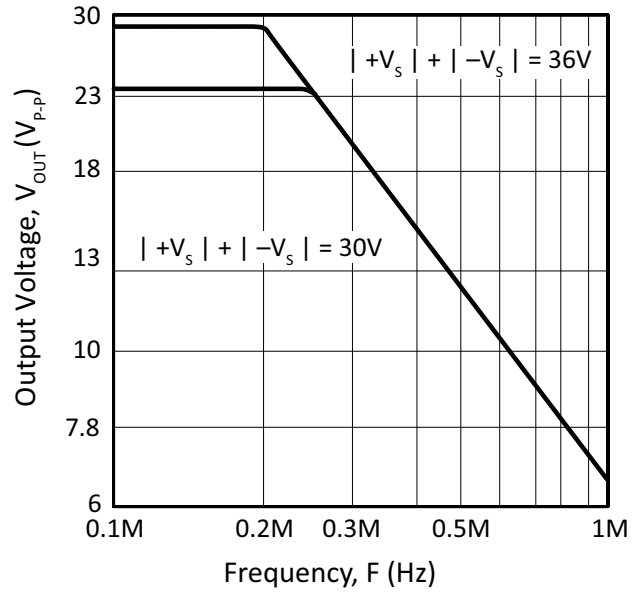

Figure 10: Bias Current

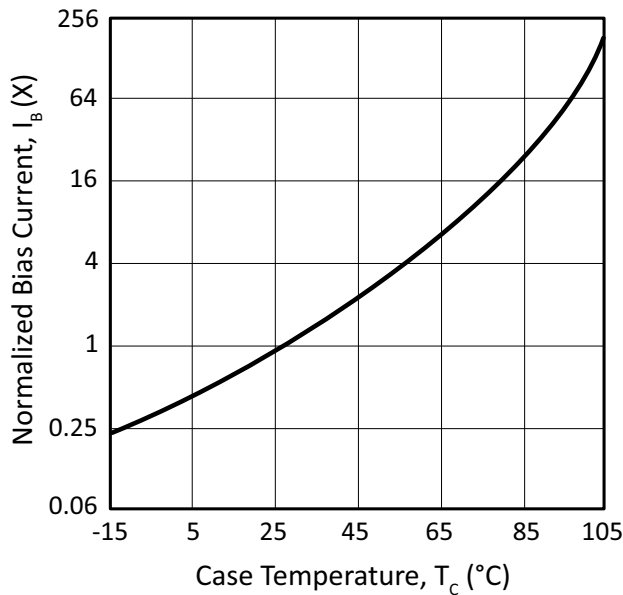

Figure 11: Common Mode Rejection

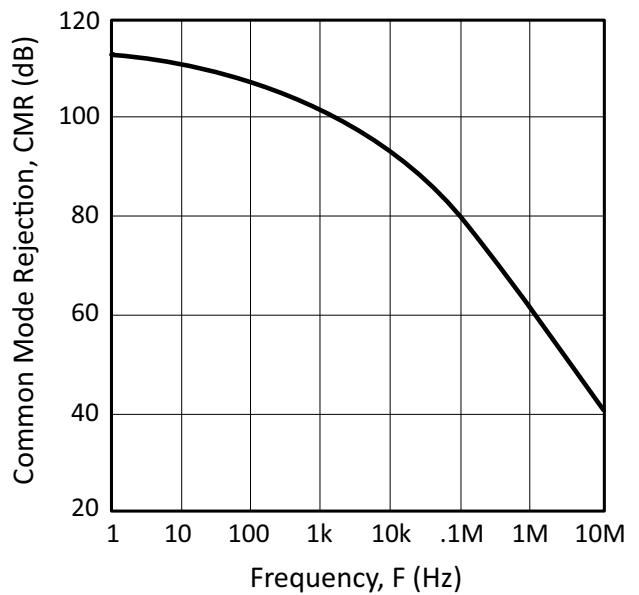

Figure 12: Power Supply Rejection

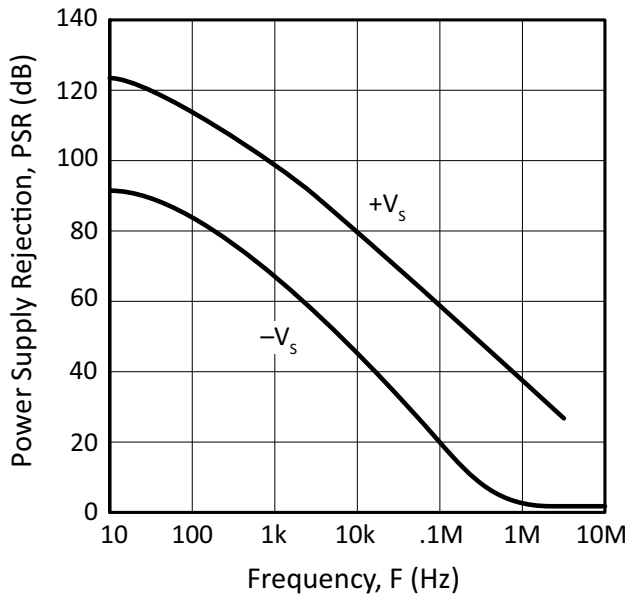

Figure 13: Input Noise

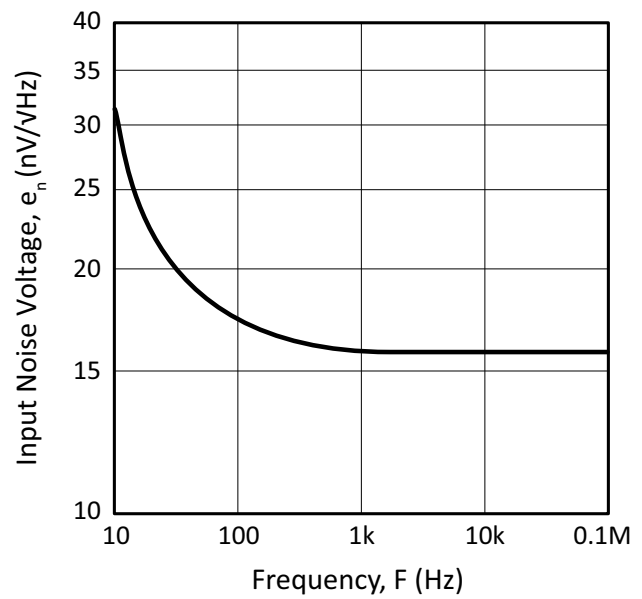

Figure 14: Settling Time

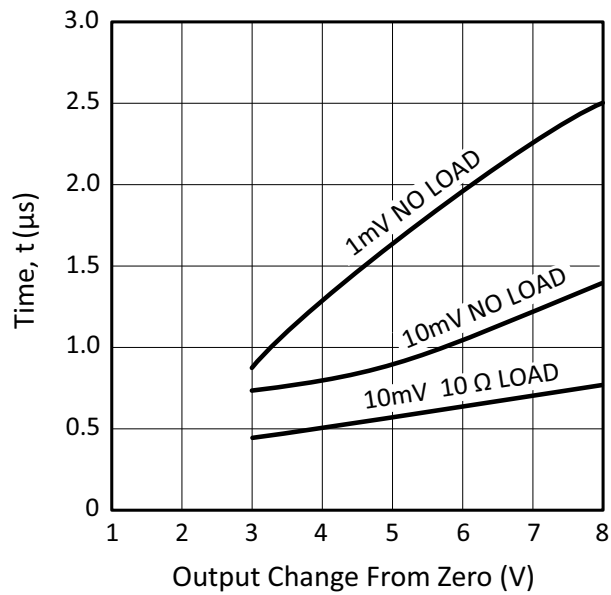

Figure 15: Quiescent Current

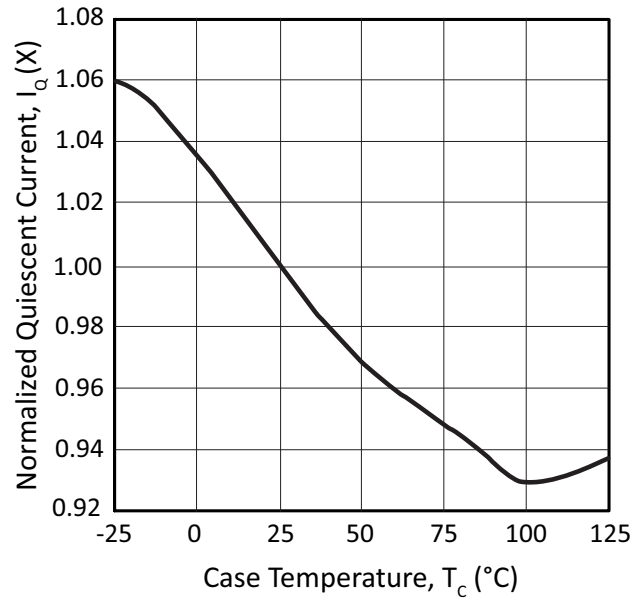

Figure 16: Harmonic Distortion

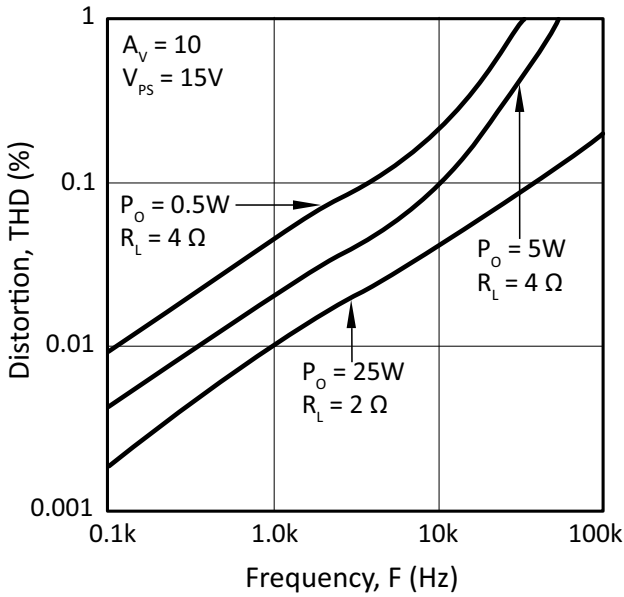

Figure 17: Pulse Response

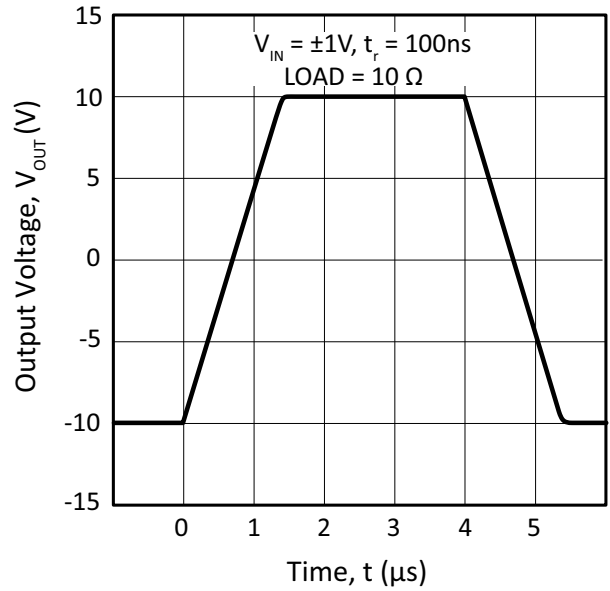

Figure 18: Pulse Response

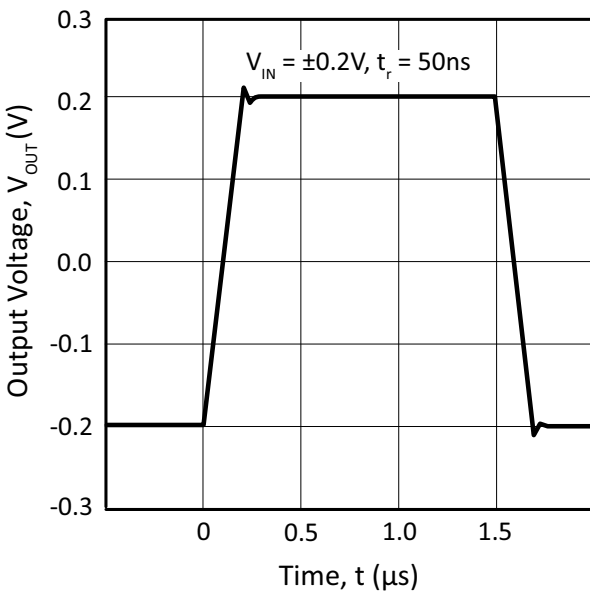
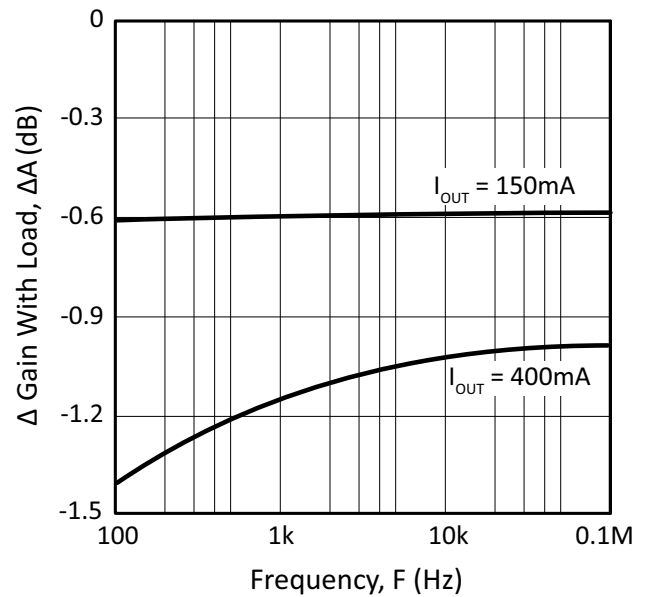

Figure 19: Loading Effects



SAFE OPERATING AREA (SOA)

The SOA curves combine the effect of all limits for this Power Op Amp. For a given application, the direction and magnitude of the output current should be calculated or measured and checked against the SOA curves. This is simple for resistive loads but more complex for reactive and EMF generating loads. The following guidelines may save extensive analytical efforts:

The amplifier can handle any EMF generating or reactive load and short circuits to the supply rails or shorts to common if the current limits are set as follows at $T_c = 85^\circ\text{C}$.

$\pm V_S$	Short to $\pm V_S$ C, L, or EMF Load	Short to Common
18V	0.9A	1.8A
15V	1.0A	2.1A
10V	1.6A	3.2A

These simplified limits may be exceeded with further analysis using the operating conditions for a specific application.

Figure 20: SOA

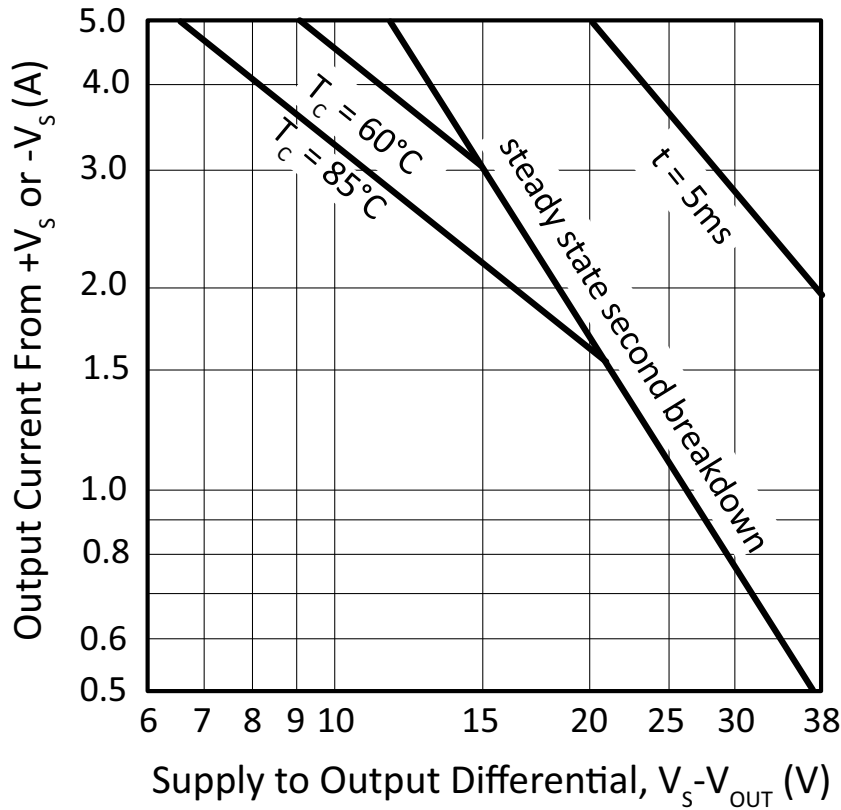

GENERAL

Please read Application Note 1 “General Operating Considerations” which covers stability, supplies, heat sinking, mounting, current limit, SOA interpretation, and specification interpretation. Visit www.apexanalog.com for Apex Microtechnology’s complete Application Notes library, Technical Seminar Workbook, and Evaluation Kits.

TYPICAL APPLICATION

Vehicular Sound System Power Stage

When system voltages are low and power is at a premium, the PA16 is a natural choice. The circuit below (figure 21) utilizes not only the feature of low internal loss of the PA16, but also its very low distortion level to implement a crystal clear audio amplifier suitable even for airborne applications. This circuit uses AC coupling of both the input signal and the gain circuit to render DC voltage across the speaker insignificant. The resistor and capacitor across the inputs form a stability enhancement network. The $0.27\ \Omega$ current limit resistors provide protection in the event of an output short circuit.

Figure 21: Typical Application

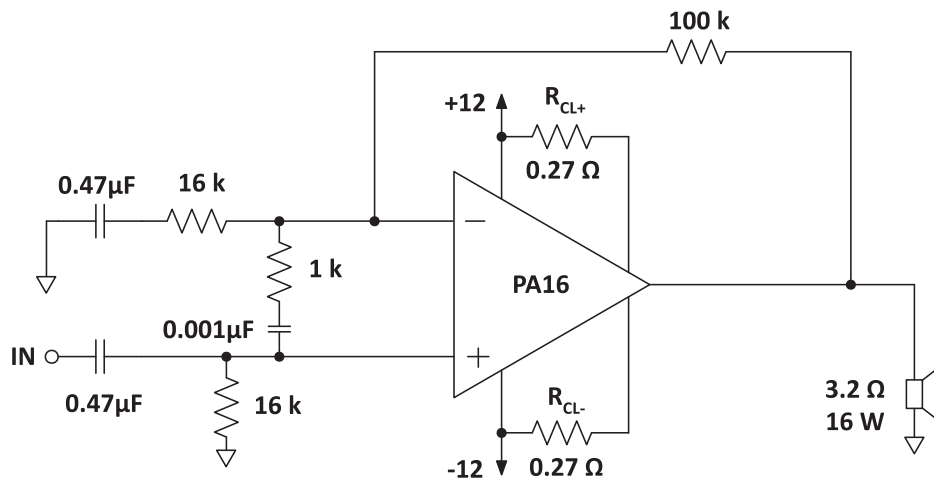

CURRENT LIMIT

Proper operation requires the use of two current limit resistors, connected as shown in the external connection diagram. The minimum value for R_{CL} is $0.12\ \Omega$, however for optimum reliability it should be set as high as possible. Refer to the “General Operating Considerations” section of the handbook for current limit adjust details.

DEVICE MOUNTING

The case (mounting flange) is electrically isolated and should be mounted directly to a heatsink with thermal compound. Screws with Belleville spring washers are recommended to maintain positive clamping pressure on heatsink mounting surfaces. Long periods of thermal cycling can loosen mounting screws and increase thermal resistance.

Since the case is electrically isolated (floating) with respect to the internal circuits it is recommended to connect it to common or other convenient AC ground potential.

PACKAGE OPTIONS

Part Number	Apex Package Style	Description
PA16	DP	12-pin SIP
PA16A	DP	12-pin SIP
PA16EE	EE	12-pin SIP w/ formed leads

PACKAGE STYLE DP

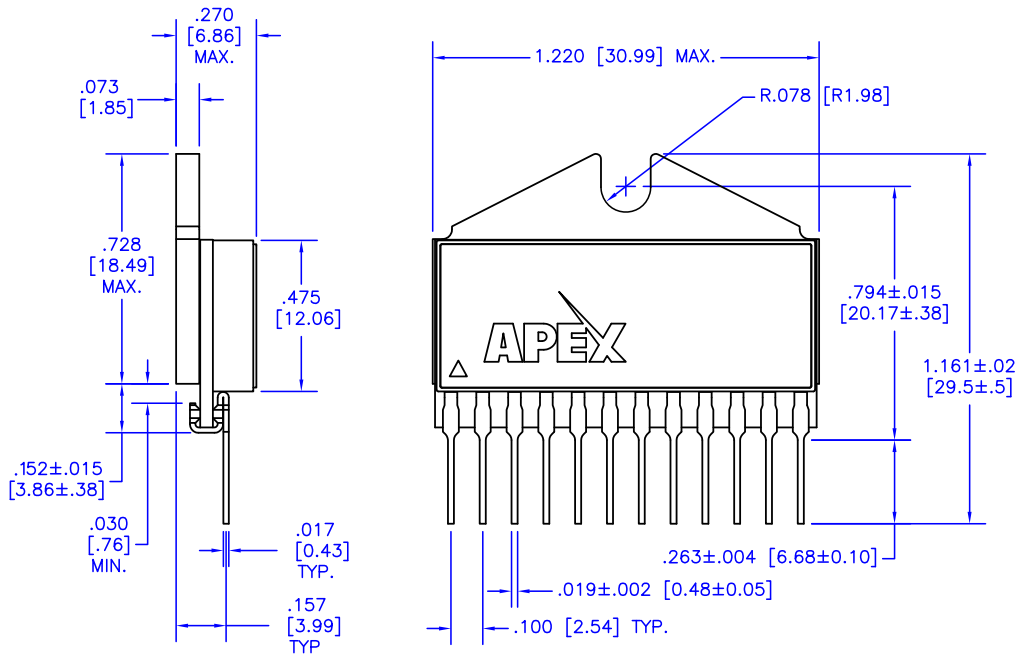
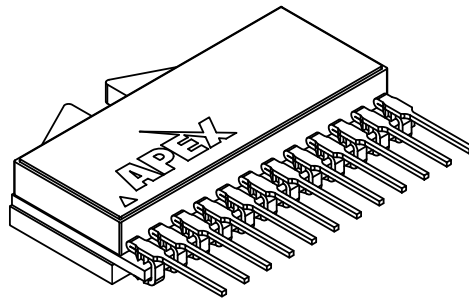

NOTES:

1. Dimensions are inches & [mm].
2. Triangle on lid denotes pin 1.
3. Pins: Alloy 510 phosphor bronze plated with matte tin (150 – 300µ”) over nickel (50 µ” max.) underplate.
4. Package: Vectra liquid crystal polymer, black
5. Epoxy-sealed & ultrasonically welded non-hermetic package.
6. Package weight: .367 oz. [11.41 g]

PACKAGE STYLE EE

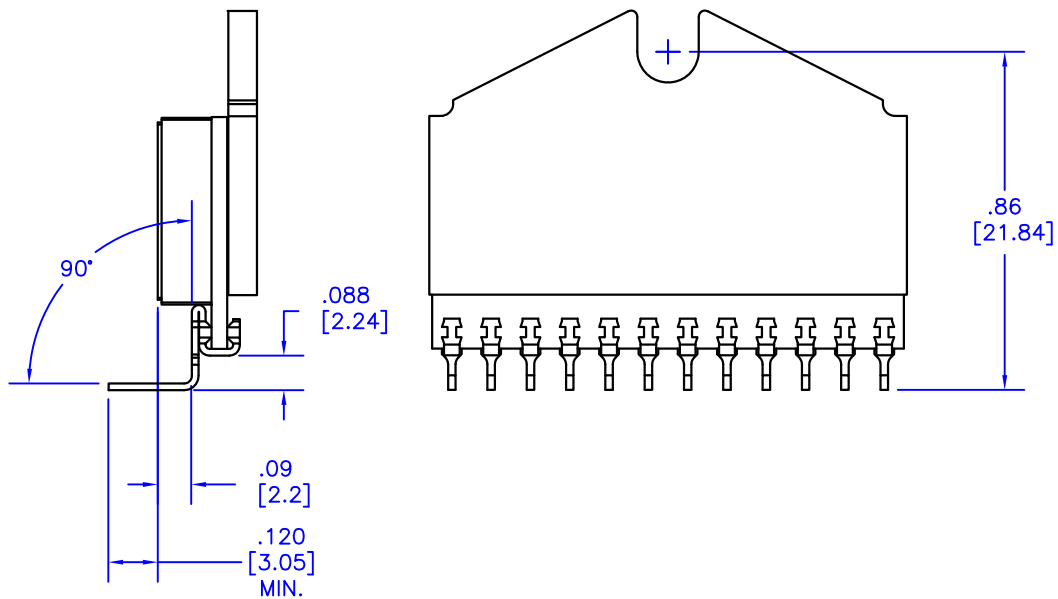
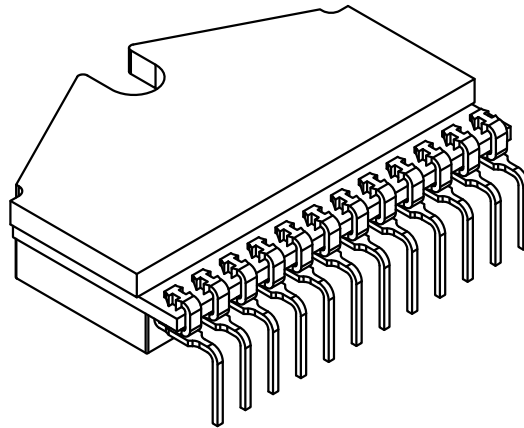

NOTES:

1. Dimensions are inches & [mm].
2. For other dimensions and information on this package with unformed leads, see package DP.