

# SIDEWINDER® - CURRENT SENSOR

PA320XNL Series

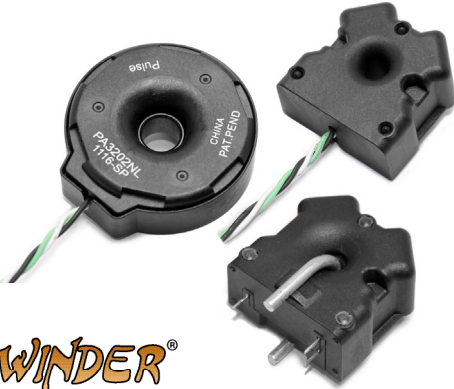

- Ⓟ 50/60 Hz, Single Phase, AC Current Sensor
- Ⓟ Dynamic Range from 0.1 to 1000 Amps
- Ⓟ Meets ANSI C12.20 Accuracy Class 0.2
- Ⓟ Meets IEC 62053-21 class 1
- Ⓟ Phase error < 0.05 degree
- Ⓟ Bandwidth 500KHz
- Ⓟ Immune to external AC magnetic fields
- Ⓟ Immune to DC current & DC magnetic field
- Ⓟ Very low temperature coefficient
- Ⓟ Patent pending

Electrical Specifications at 25°C Temp Range -40°C to 130°C							Actual Secondary Output Voltage (V <sub>sa</sub> )	
Part Number	Accuracy Class <sup>3</sup>	Kr <sup>4</sup> (μΩ/Hz typ)	Pri-Sec Isolation (V min)	L <sub>s</sub> <sup>5</sup> (mH typ)	R <sub>s</sub> <sup>6</sup> (Ohms typ)	SRF <sup>7</sup> (Hz typ)	@ 50 Hz (μV/A) <sup>1</sup>	@ 60 Hz (μV/A) <sup>1</sup>
PA3202NL	0.2	8.33	6,000	1.75	57.3	160,000	416	500
PA3206NL	0.2	7.66	6000	1.14	37.6	200,000	383	460
PA3208NL	0.2	7.66	6000	1.14	37.6	200,000	383	460

EQUATIONS:  $V_{sa} = K_r F_r I_{pa}$   
 $F_r \ll SRF$

## NOTES:

- Output Voltage is proportional to the derivative (di/dt) of the input current based on the Rogowski Coil principle.
- All current and voltages assumed to be sinusoidal waveforms at Fr, the constant rated frequency in Hz, measured as RMS values.
- Accuracy Class per IEC 60044-1 Table 11 where:
  - Percentage current error =  $((Kr \cdot Fr \cdot I_{pa} - V_{out}) / V_{out}) \times 100$
  - Phase displacement = the difference between the primary current (I<sub>pa</sub>) phase vector and the (secondary voltage (V<sub>out</sub>)) phase vector minus 90 degrees)
- Kr = Rated transformation constant
- L<sub>s</sub> = Secondary winding inductance
- R<sub>s</sub> = Secondary winding resistance
- SRF = Self Resonate Frequency
- I<sub>pa</sub> = Actual primary current
- V<sub>sa</sub> = Actual secondary output voltage

## Low Frequency Equivalent Circuit

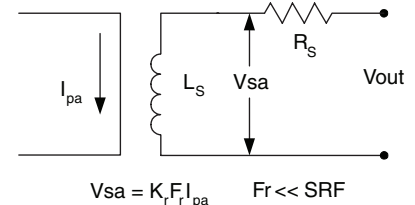

## Mechanicals

## Schematics

### PA3202NL

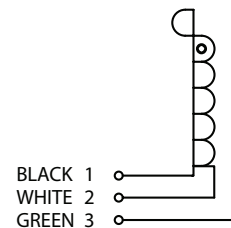
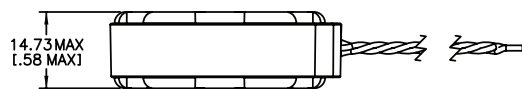
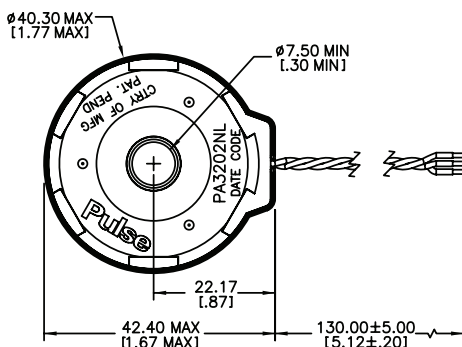

# SIDEWINDER® - CURRENT SENSOR

PA320XNL Series



## Mechanicals

## Schematics

### PA3206NL

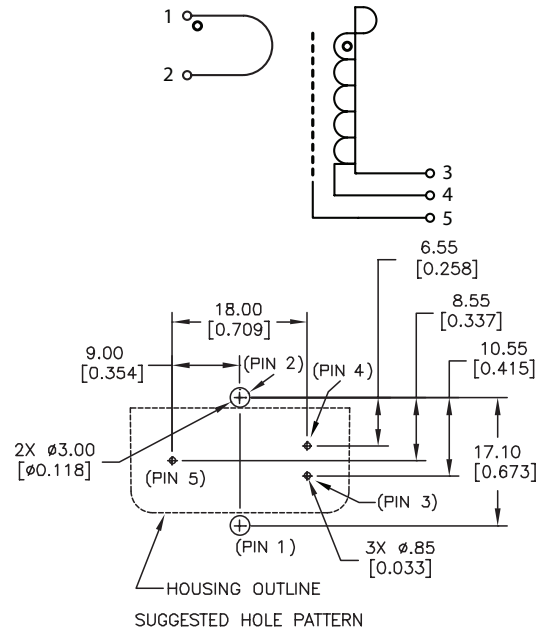
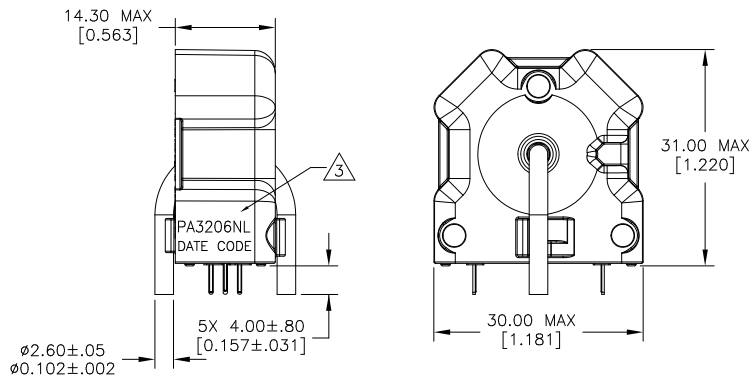

## Mechanicals

## Schematics

### PA3208NL

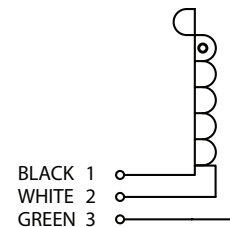
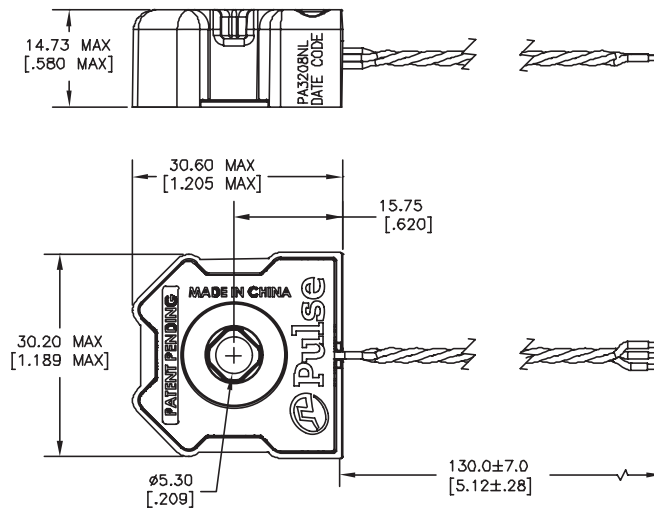

## For More Information

### Pulse Worldwide Headquarters

15255 Innovation Drive Ste 100  
 San Diego, CA 92128  
 U.S.A.

### Pulse Europe

Pulse Electronics GmbH  
 Am Rottland 12  
 58540 Meinerzhagen  
 Germany

### Pulse China Headquarters

Pulse Electronics (ShenZhen) CO., LTD  
 D708, Shenzhen Academy of  
 Aerospace Technology,  
 The 10th Keji South Road,  
 Nanshan District, Shenzhen, P.R.  
 China 518057

### Pulse North China

Room 2704/2705  
 Super Ocean Finance Ctr.  
 2067 Yan An Road West  
 Shanghai 200336  
 China

### Pulse South Asia

135 Joo Seng Road  
 #03-02  
 PM Industrial Bldg.  
 Singapore 368363

### Pulse North Asia

1F., No.111 Xiyuan Rd  
 Zhongli City  
 Taoyuan City 32057  
 Taiwan (R.O.C)

Tel: 858 674 8100  
 Fax: 858 674 8262

Tel: 49 2354 777 100  
 Fax: 49 2354 777 168

Tel: 86 755 33966678  
 Fax: 86 755 33966700

Tel: 86 21 62787060  
 Fax: 86 21 62786973

Tel: 65 6287 8998  
 Fax: 65 6280 0080

Tel: 886 3 4356768  
 Fax: 886 3 4356820

Performance warranty of products offered on this data sheet is limited to the parameters specified. Data is subject to change without notice. Other brand and product names mentioned herein may be trademarks or registered trademarks of their respective owners. © Copyright, 2017. Pulse Electronics, Inc. All rights reserved.