

## Dual Power Operational Amplifiers

RoHS  
COMPLIANT

### FEATURES

- RoHS Compliant
- Low Cost
- Wide Bandwidth - 1.1 MHz
- High Output Current - 2.5A (Combined)
- Wide Common Mode Range Includes Negative Supply
- Wide Supply Voltage Range Single supply: 5V to 40V Split Supplies:  $\pm 2.5V$  to  $\pm 20V$
- Low Quiescent Current
- Very Low Distortion

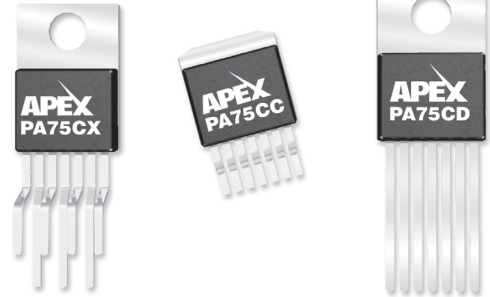

### APPLICATIONS

- Half And Full Bridge Motor Drivers
- Audio Power Amplifier
- Ideal for Single Supply Systems 5V Peripherals, 12V Automotive, 28V Avionic

### PACKAGING OPTIONS

- 7 TO-220 Plastic Package (PA75CD)
- 7 TO-220 with Staggered Lead Form (PA75CX)
- 7 DDPAK Surface Mount Package (PA75CC)

### DESCRIPTION

The amplifier design consists of a dual power op amp on a single monolithic die. Side B of the dual monolithic is configured as a unity gain buffer to increase the current capability of the primary side A. The use of two PA75 amplifiers provides a cost-effective solution to applications where multiple amplifiers are required or a bridge configuration is needed. Very low harmonic distortion of 0.02% THD and low  $I_Q$  makes the PA75 a good solution for power audio applications.

The PA75 is available in three standard package designs. The surface mount version of the PA75, the PA75CC, is an industry standard non-hermetic plastic 7-pin DDPAK. The through hole versions of the PA75, the PA75CD and PA75CX, are industry standard non-hermetic plastic 7-pin TO-220 packages. The PA75CX is staggered lead formed and offers standard 100 mil spacing. This allows for easier PC board layout. (Please refer to the CX lead form package drawing for dimension of the PA75CX).

The monolithic amplifier is directly attached to the metal tabs of the PA75CC, PA75CD, and PA75CX. The metal tabs of the packages are directly tied to -Vs.

Figure 1: Equivalent Schematic

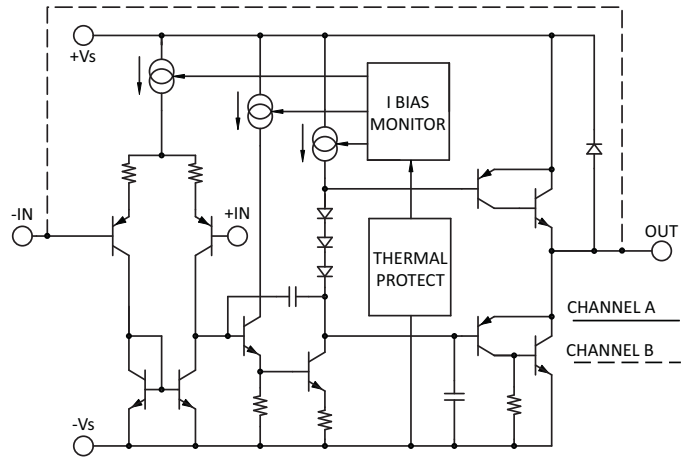

TYPICAL CONNECTION

Figure 2: Typical Connection (Parallel Mode Operation)

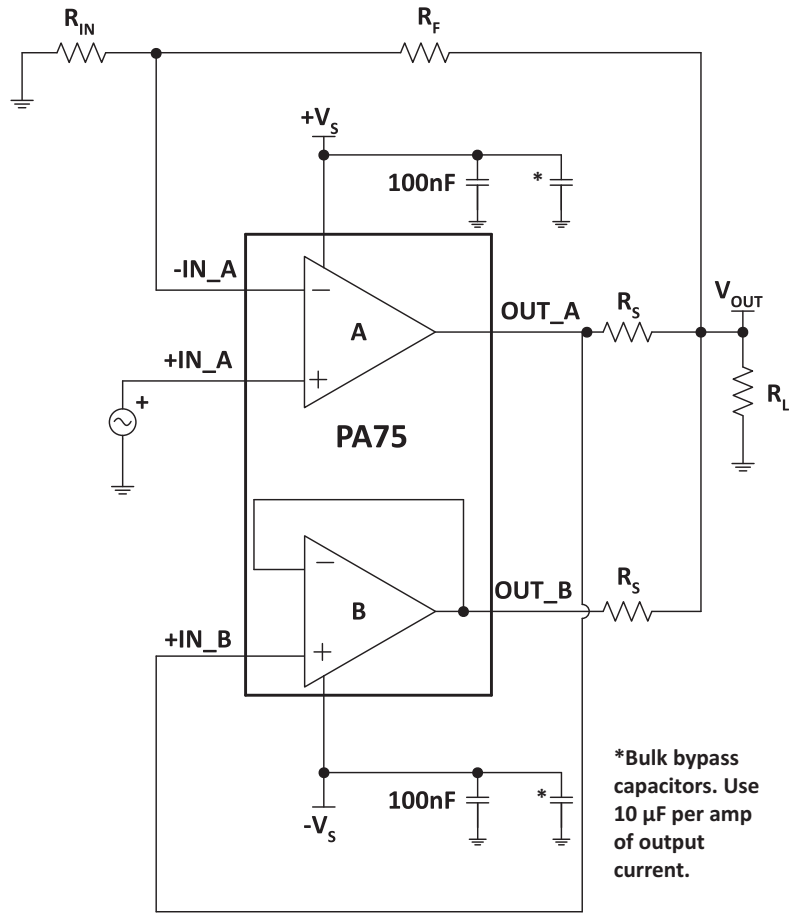

**PINOUT AND DESCRIPTION TABLE**

Figure 3: External Connections

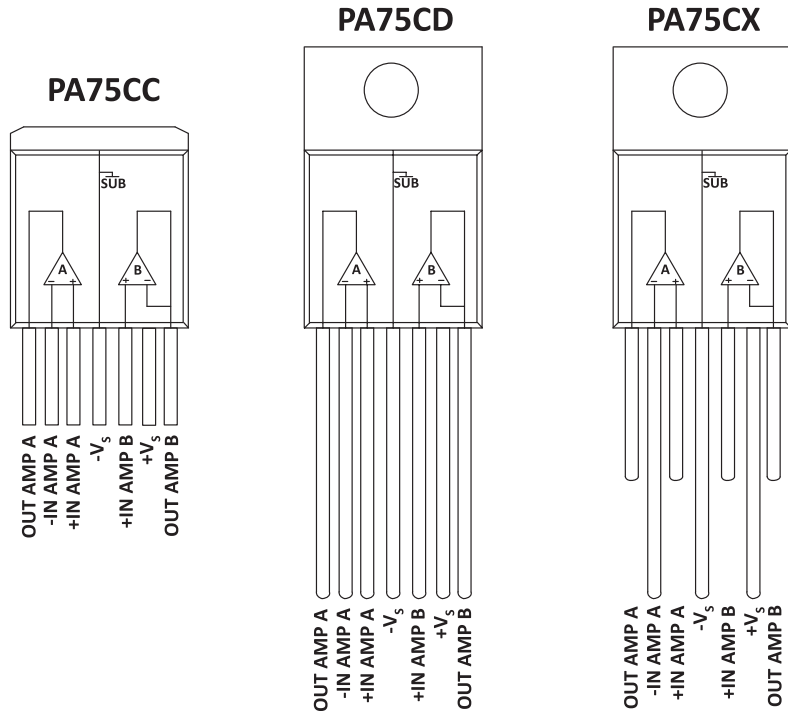

Pin Number	Name	Description
1	OUT_A	The output for channel A. Connect this pin to load and to the feedback resistors.
2	-IN_A	The inverting input for channel A.
3	+IN_A	The non-inverting input for channel A.
4	-Vs	The negative supply rail for both channels.
5	+IN_B	The non-inverting input for channel B.
6	+Vs	The positive supply rail for both channels.
7	OUT_B	The output for channel B. Connect this pin to load.

## SPECIFICATIONS

Unless otherwise noted, the following conditions apply:  $\pm V_S = \pm 15V$ ,  $T_C = 25^\circ C$ .

### ABSOLUTE MAXIMUM RATINGS

Parameter	Symbol	Min	Max	Units
Supply Voltage, total	$+V_S$ to $-V_S$	5	40	V
Output Current,	$I_O$		SOA	
Power Dissipation, internal (per amplifier)	$P_D$		19.5	W
Power Dissipation, internal (both amplifiers)	$P_D$		28.6	W
Input Voltage, differential	$V_{IN(Diff)}$		$\pm V_S$	V
Input Voltage, common mode	$V_{cm}$		$+V_S, -V_S - 0.5V$	V
Temperature, pin solder, 10s max.			220	$^\circ C$
Temperature, junction <sup>1</sup>	$T_J$		150	$^\circ C$
Temperature Range, storage		-55	150	$^\circ C$
Operating Temperature Range, case	$T_C$	-40	125	$^\circ C$

1. Long term operation at the maximum junction temperature will result in reduced product life. Derate internal power dissipation to achieve high MTTF.

### INPUT

Parameter	Test Conditions	Min	Typ	Max	Units
Offset Voltage, initial			1	15	mV
Offset Voltage vs. Temperature	Full temp range		20		$\mu V/^\circ C$
Bias Current, initial			100	500	nA
Common Mode Range	Full temp range	$-V_S$		$+V_S - 1.3$	V
Common Mode Rejection, DC	Full temp range	60	90		dB
Power Supply Rejection	Full temp range	60	90		dB
Channel Separation	$I_{OUT} = 500mA$ , $f = 1$ kHz	50	68		dB
Input Noise Voltage	$R_S = 100 \Omega$ , $f = 1$ to 100 kHz		22		nV/√Hz

### GAIN

Parameter	Test Conditions	Min	Typ	Max	Units
Open Loop Gain	Full temp range	89	100		dB
Gain Bandwidth Product	$A_V = 40dB$	0.9	1.4		MHz
Power Bandwidth	$V_{O(P-P)} = 28V$		13.6		kHz
Phase Margin	Full temp range, $R_L = 2$ k $\Omega$ , $C_L = 100pF$		65		$^\circ$

**OUTPUT**

Parameter	Test Conditions	Min	Typ	Max	Units
Current, peak				1.5	A
Slew Rate		1	1.4		V/ $\mu$ s
Voltage Swing	Full Temp Range, $I_O = 100\text{mA}$	$ V_S  - 1.1$	$ V_S  - 0.8$		V
Voltage Swing	Full Temp Range, $I_O = 1\text{A}$	$ V_S  - 1.8$	$ V_S  - 1.4$		V
Harmonic Distortion	$A_V = 1, R_2 = 50\ \Omega, V_O = 0.5V_{\text{RMS}}, f = 1\ \text{kHz}$		0.02		%

**POWER SUPPLY**

Parameter	Test Conditions	Min	Typ	Max	Units
Voltage, $V_{SS}^1$		5	30	40	V
Current, quiescent, total			8	10	mA

1.  $+V_S$  and  $-V_S$  denote the positive and negative supply rail respectively.  $V_{SS}$  denotes the total rail-to-rail supply voltage.

**THERMAL**

Parameter	Test Conditions	Min	Typ	Max	Units
Resistance, DC, junction to case (single)			5.84	6.42	$^{\circ}\text{C}/\text{W}$
Resistance, AC, junction to case (single)			4.38	4.81	$^{\circ}\text{C}/\text{W}$
Resistance, DC, junction to case (both)			3.97	4.36	$^{\circ}\text{C}/\text{W}$
Resistance, AC, junction to case (both)			2.98	3.27	$^{\circ}\text{C}/\text{W}$
Resistance, junction to air (CD, CX)			60		$^{\circ}\text{C}/\text{W}$
Resistance, junction to air (CC) <sup>1</sup>			27		$^{\circ}\text{C}/\text{W}$
Temperature Range, case	Meets full range specs	-25		+85	$^{\circ}\text{C}$

1. Heat tab attached to 3/32" FR-4 board with 2oz. copper. Topside copper area (heat tab directly attached) = 1000 sq. mm, backside copper area = 2500 sq. mm, board area = 2500 sq. mm.

TYPICAL PERFORMANCE GRAPHS

Figure 4: Quiescent Current

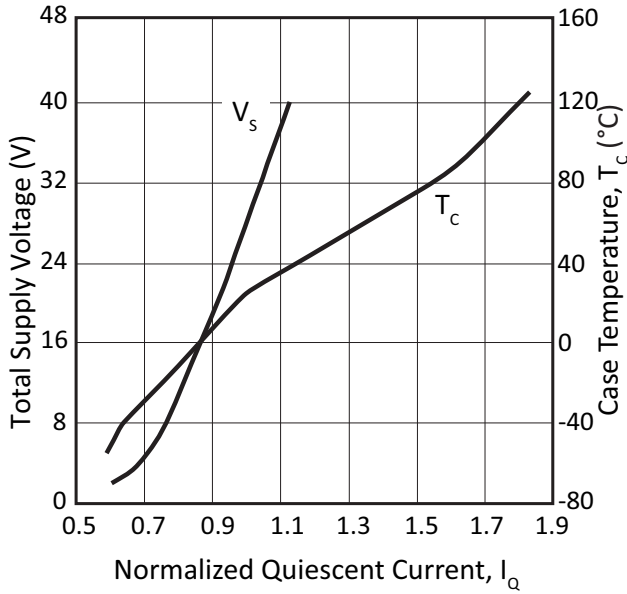

Figure 5: Bias Current

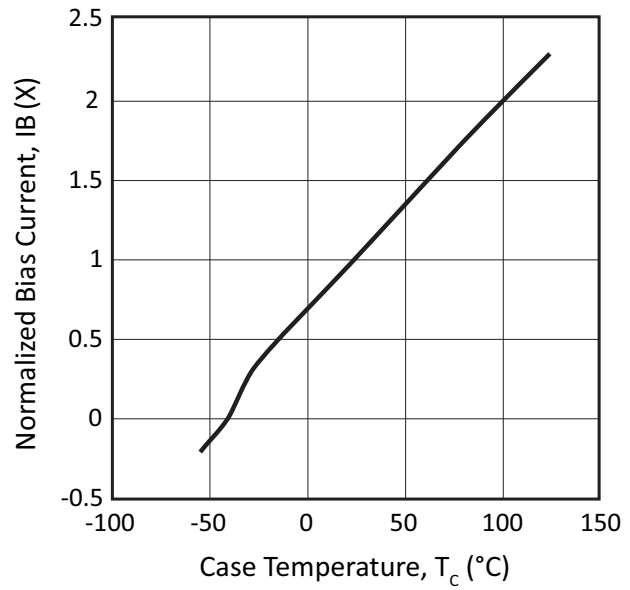

Figure 6: Offset Voltage

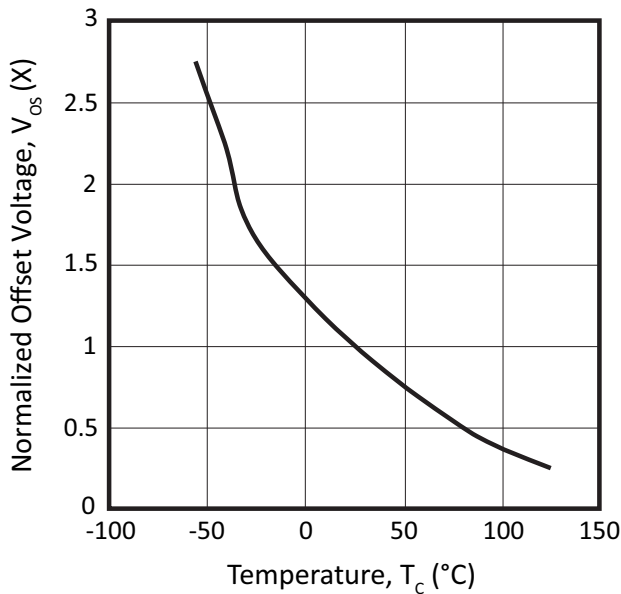
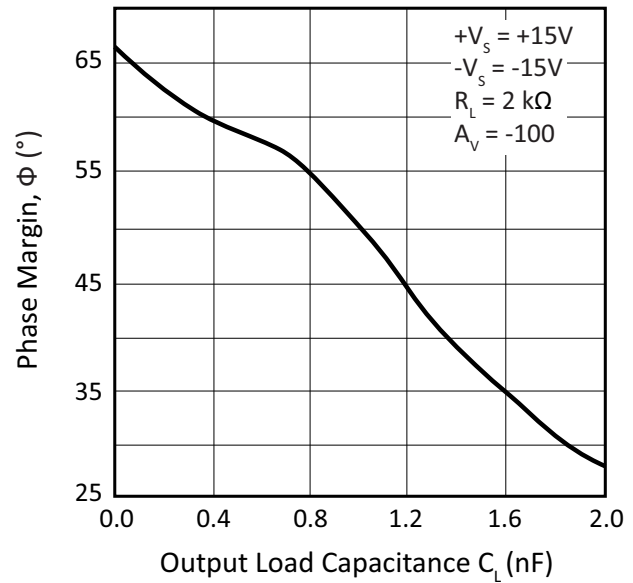
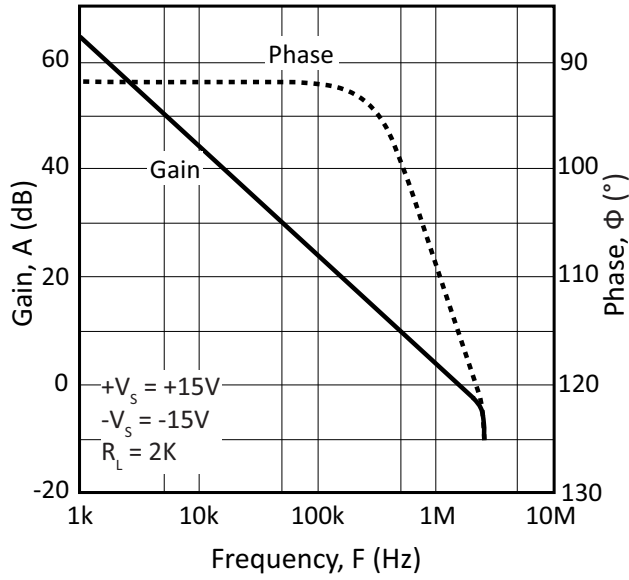

Figure 7: Phase Margin vs. Output Load Capacitance



**Figure 8: Voltage Gain & Phase vs. Frequency**



**Figure 9: Output Voltage Swing**

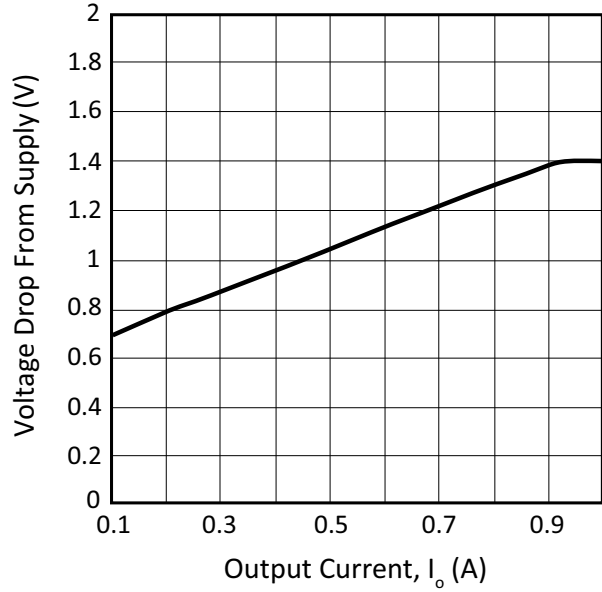

**Figure 10: Pulse Response**

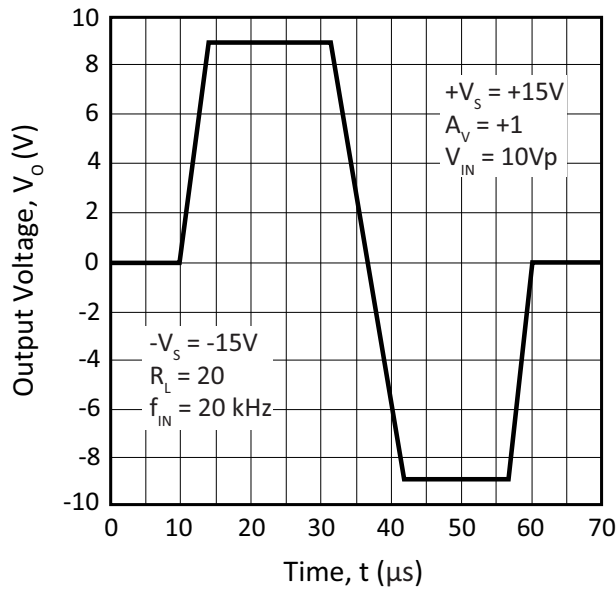

**Figure 11: Pulse Response**

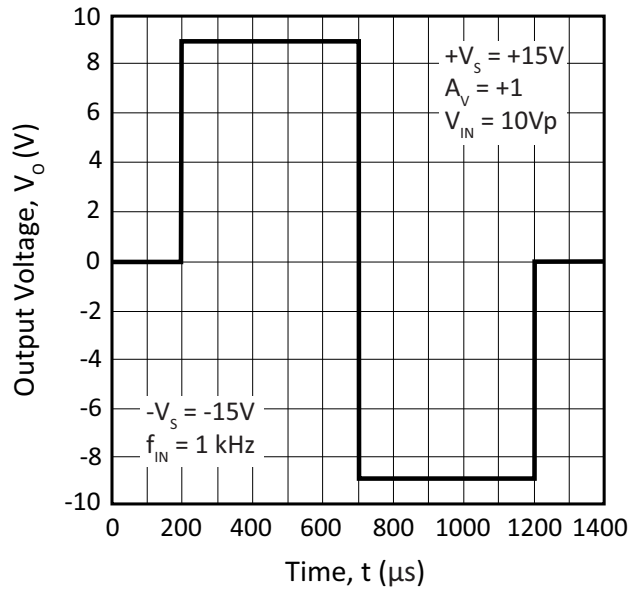

**SAFE OPERATING AREA (SOA)**

The SOA curves combine the effect of all limits for this power op amp. For a given application, the direction and magnitude of the output current should be calculated or measured and checked against the SOA curves. This is simple for resistive loads but more complex for reactive and EMF generating loads.

**Figure 12: SOA**

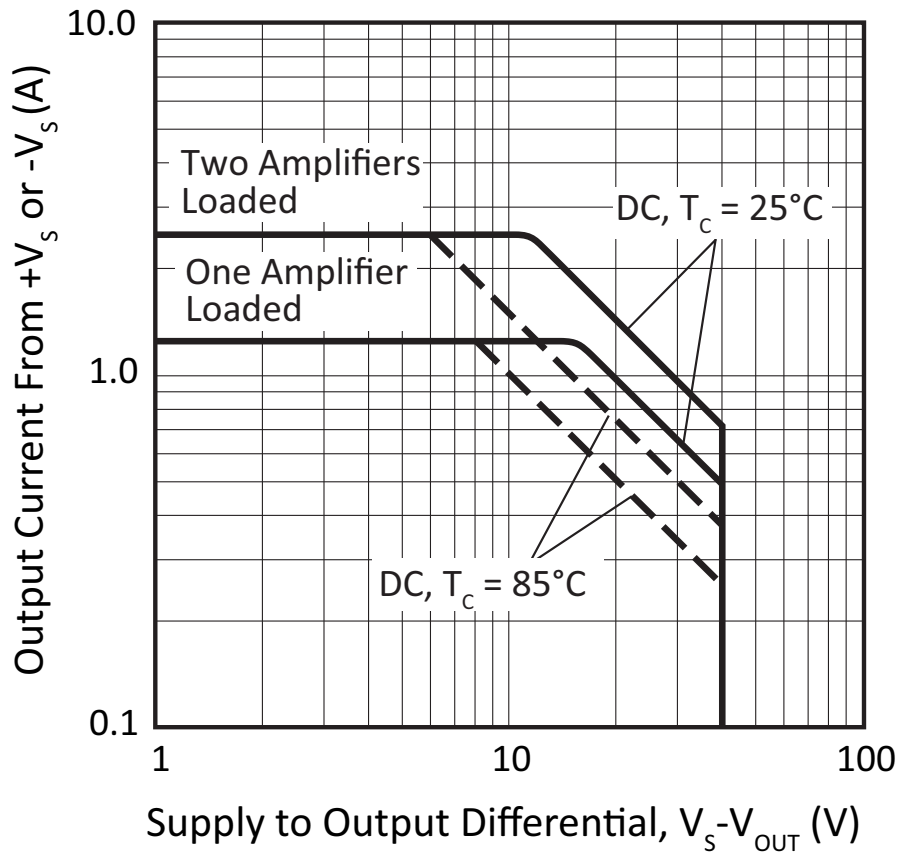



## GENERAL

Please read Application Note 1 “General Operating Considerations” which covers stability, supplies, heat sinking, mounting, current limit, SOA interpretation, and specification interpretation. Visit [www.apexanalog.com](http://www.apexanalog.com) for Apex Microtechnology’s complete Application Notes library, Technical Seminar Workbook, and Evaluation Kits.

## TYPICAL APPLICATION

Combining the power op amp (primary channel A) and the unity gain buffer (follower channel B) in a parallel connection yields a single 2.5A amplifier.  $R_I$  and  $R_F$  can set up channel A for the required gain for the overall circuit. Small values of  $R_S$  (sense resistors) are used on the outputs to improve current sharing characteristics. The primary amplifier can be configured in inverting or non-inverting gain configurations.

Figure 13: Typical Application

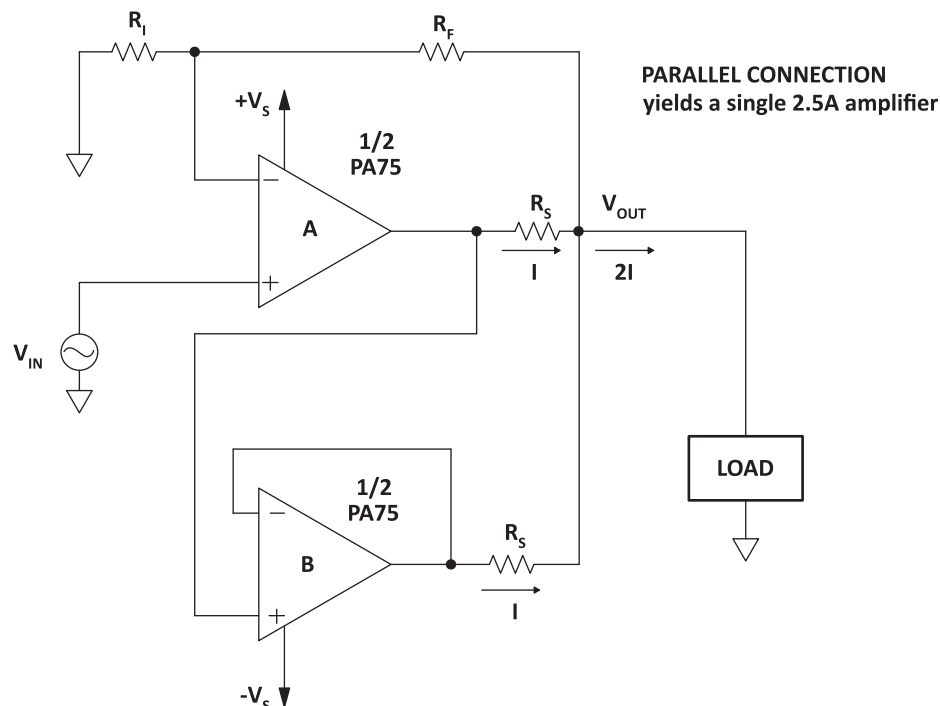

## STABILITY CONSIDERATIONS

All monolithic power op amps use output stage topologies that present special stability problems. This is primarily due to non-complementary (both devices are NPN) output stages with a mismatch in gain and phase response for different polarities of output current. It is difficult for the op amp manufacturer to optimize compensation for all operating conditions. For applications with load current exceeding 300mA, oscillation may appear. The oscillation may occur only with the output voltage swing at the negative or positive half cycle. Under most operating and load conditions acceptable stability can be achieved by providing a series RC snubber network connected from the output to ground. The recommended component values of the network are,  $R_{SN} = 10 \Omega$  and  $C_{SN} = 0.01\mu F$ . Please refer to Application Note 1 for further details.

Figure 14: Stability

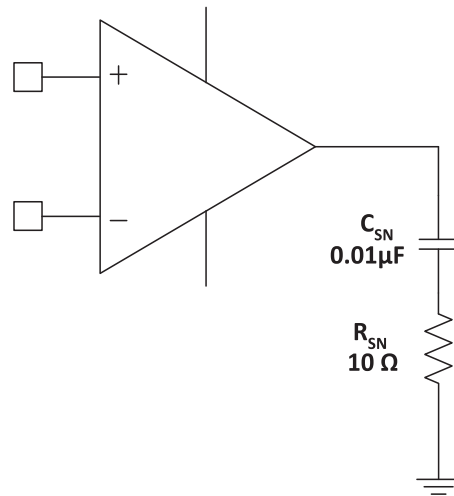

## THERMAL CONSIDERATIONS

The PA75CD and CX have a large exposed copper heat tab to which the monolithic is directly attached. The PA75CD and CX may require an electrically insulating thermal washer, since the tab is directly tied to  $-V_S$ . This can result in a thermal impedance  $R_{CS}$  of up to  $1^\circ\text{C}/\text{W}$  or greater.

The PA75CC has a large exposed integrated copper heatslug to which the monolithic is directly attached. The solder connection of the heatslug to a minimum of 1 square inch foil area of the printed circuit board will result in thermal performance of  $25^\circ\text{C}/\text{W}$  junction to air rating of the PA75CC. Solder connection to an area of 1 to 2 square inches of foil is required for minimal power applications.

Where the PA75CC is used in higher power applications, it is necessary to use surface mount techniques of heatsinking. Surface mount techniques include the use of a surface mount fan in combination with a surface mount heatsink on the backside of the FR4/PC board with through hole thermal vias. Other highly thermal conductive substrate board materials are available for maximum heat sinking.

Figure 15: Power Derating

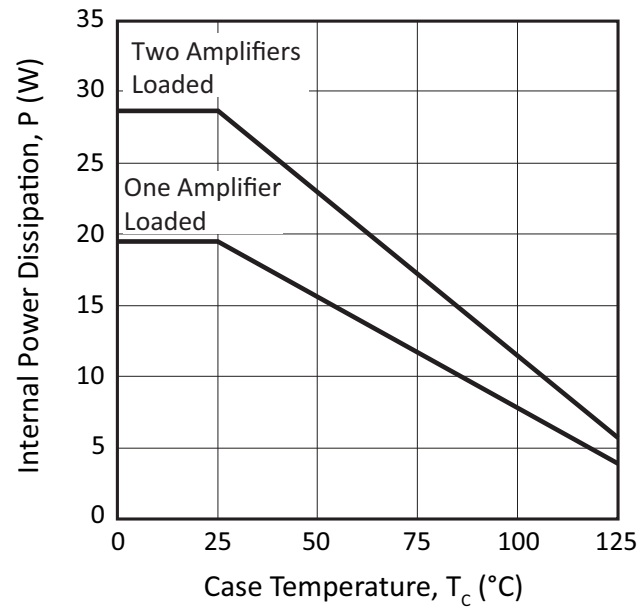

## MOUNTING PRECAUTIONS

1. Always use a heat sink. Even unloaded the PA75 can dissipate up to 0.4 Watts.
2. Avoid bending the leads. Such action can lead to internal damage.
3. Always fasten the tab of the CD and CX package to the heat sink before the leads are soldered to fixed terminals.
4. Strain relief must be provided if there is any probability of axial stress to the leads.

## PACKAGE OPTIONS

Part Number	Apex Package Style	Description
PA75CD	CD	7-pin TO-220
PA75CX	CX	7-pin TO-220 w/ staggered leads
PA75CC	CC	7-pin surface mount DDPAK

### PACKAGE STYLE CD

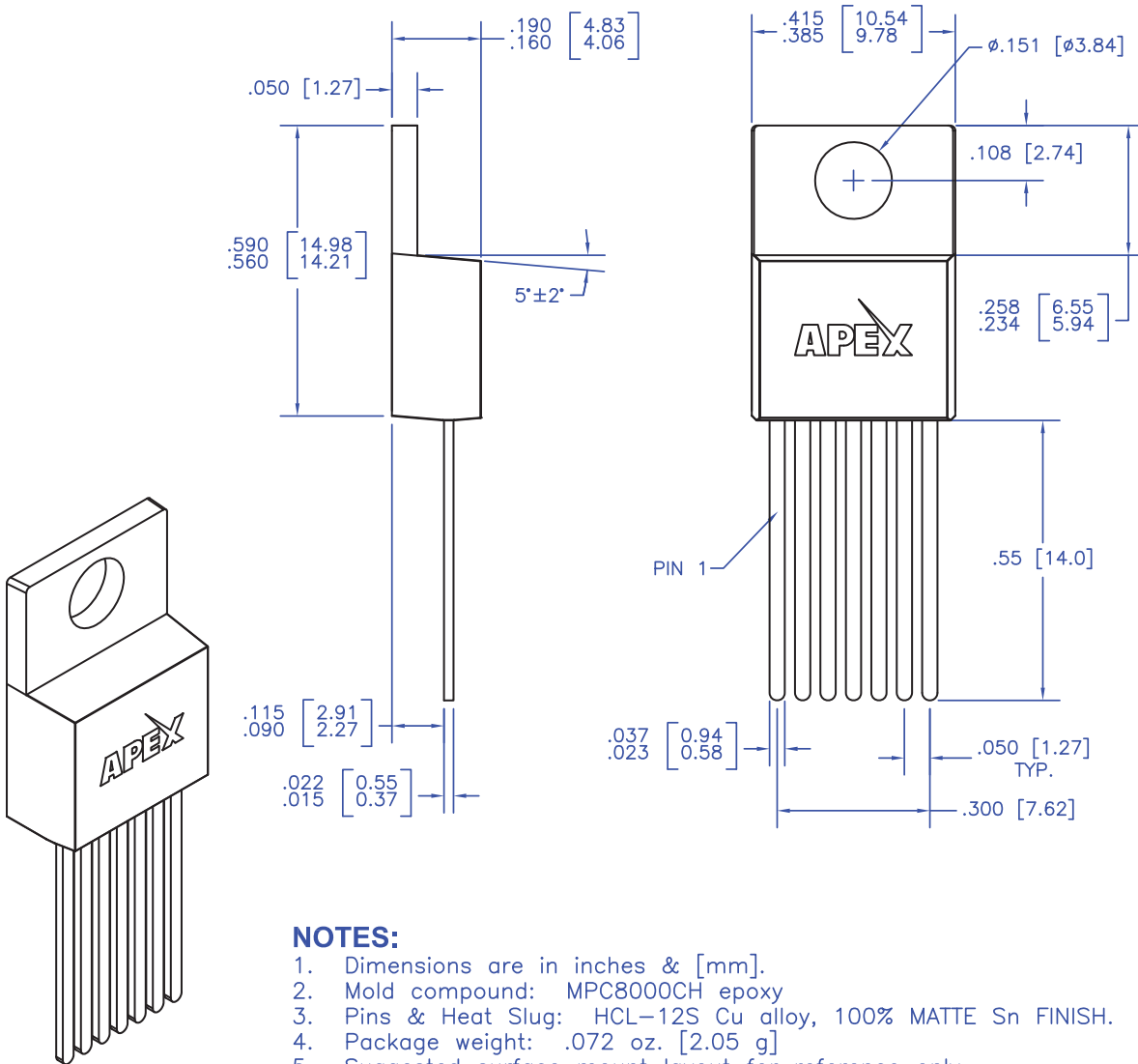

#### NOTES:

1. Dimensions are in inches & [mm].
2. Mold compound: MPC8000CH epoxy
3. Pins & Heat Slug: HCL-12S Cu alloy, 100% MATTE Sn FINISH.
4. Package weight: .072 oz. [2.05 g]
5. Suggested surface mount layout for reference only.

**PACKAGE STYLE CX**

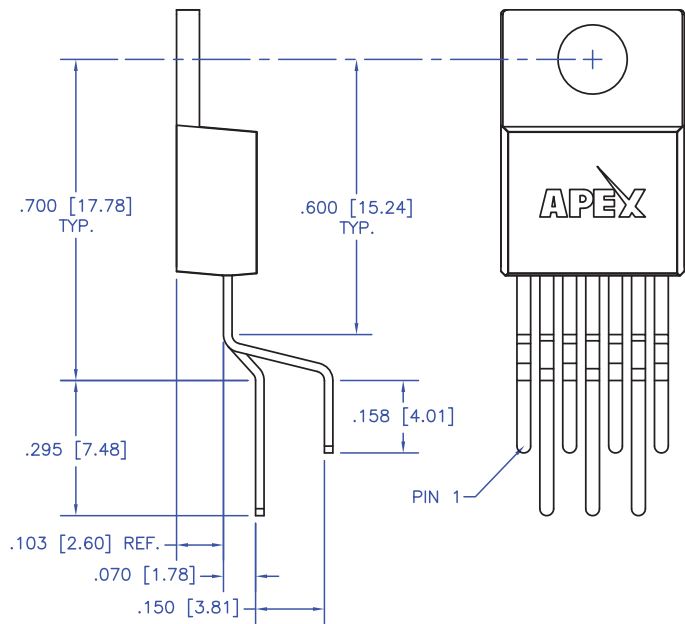
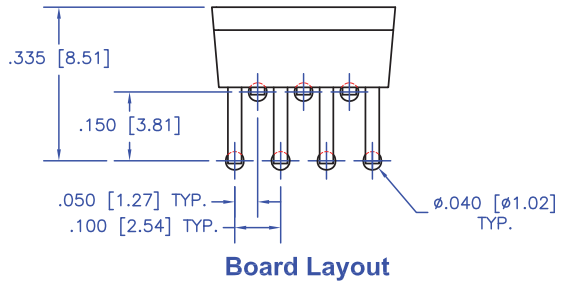
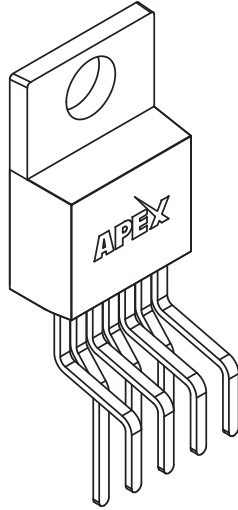

**NOTES:**

1. Dimensions are inches & [mm].
2. For other information on this package with unformed leads, see package CD.
3. Suggested board layout for reference only.