

## High Voltage Power Operational Amplifiers

RoHS  
COMPLIANT

### FEATURES

- Low Bias Current, Low Noise — FET Input
- Fully Protected Input — Up to  $\pm 150V$
- Wide Supply Range —  $\pm 15V$  to  $\pm 150V$



### APPLICATIONS

- High Voltage Instrumentation
- Electrostatic Transducers & Deflection
- Programmable Power Supplies up to 290V
- Analog Simulators

### DESCRIPTION

The PA83 is a high voltage operational amplifier designed for output voltage swings up to  $\pm 145V$  with a dual ( $\pm$ ) supply or 290V with a single supply. Its input stage is protected against transient and steady state overvoltages up to and including the supply rails. High accuracy is achieved with a cascode input circuit configuration. All internal biasing is referenced to a zener diode fed by a FET constant current source. As a result, the PA83 features an unprecedented supply range and excellent supply rejection. The output stage is biased in the class A/B mode for linear operation. Internal phase compensation assures stability at all gain settings without need for external components. Fixed current limits protect these amplifiers against shorts to common at supply voltages up to 120V. For operation into inductive loads, two external flyback pulse protection diodes are recommended. However, a heatsink may be necessary to maintain the proper case temperature under normal operating conditions.

This hybrid circuit utilizes beryllia (BeO) substrates, thick (cermet) film resistors, ceramic capacitors and silicon semiconductor chips to maximize reliability, minimize size and give top performance. Ultrasonically bonded aluminum wires provide reliable interconnections at all operating temperatures. The 8-pin TO-3 package is hermetically sealed and electrically isolated. The use of compressible thermal isolation washers and/or improper mounting torque voids product warranty. Please see Application Note 1 "General Operating Considerations."

**Figure 1: Equivalent Schematic**

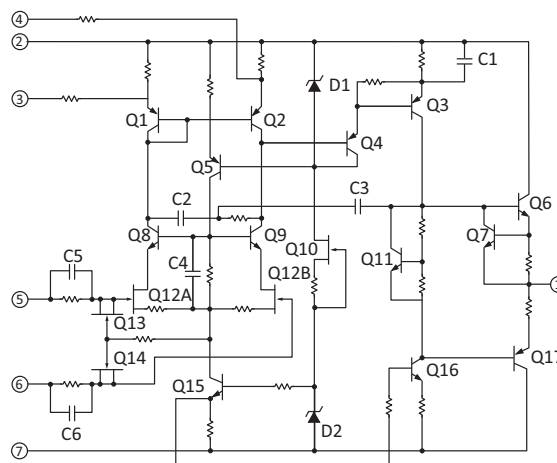

TYPICAL CONNECTION

Figure 2: Typical Connection

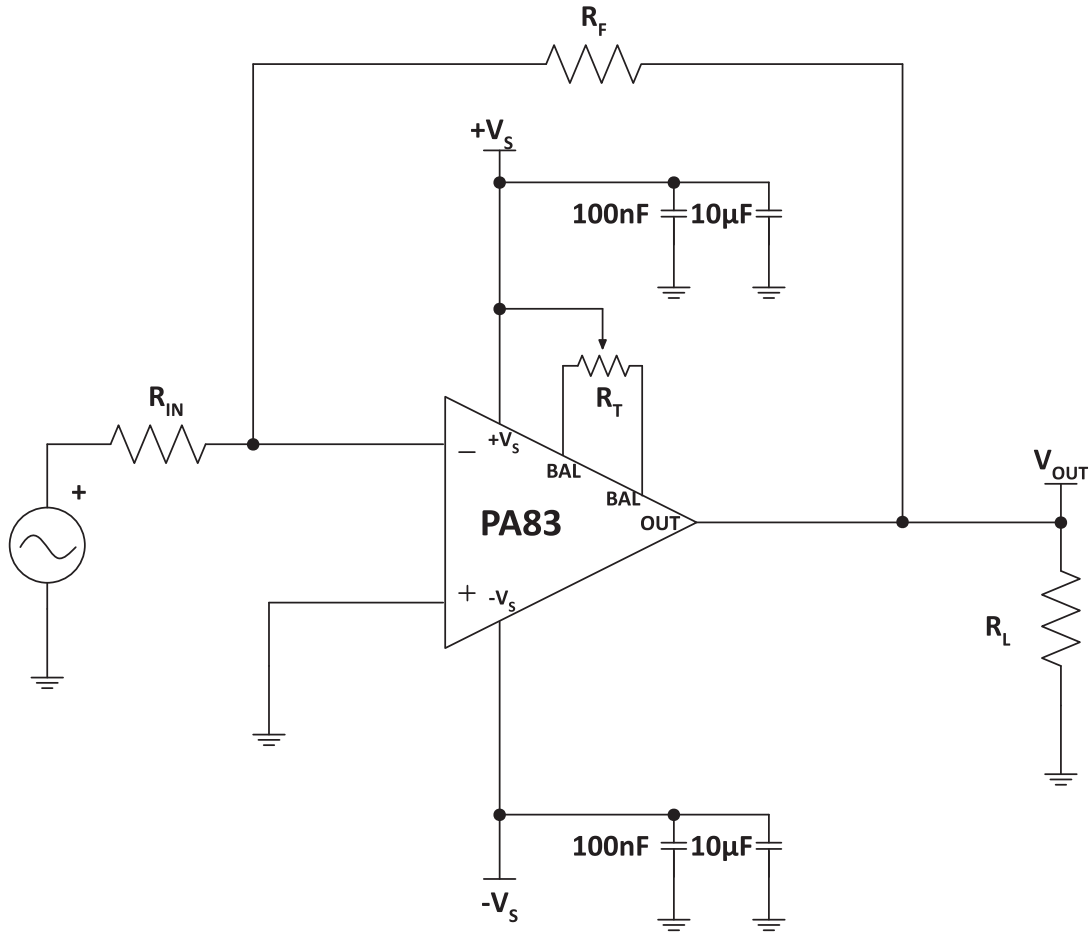

**PINOUT AND DESCRIPTION TABLE**

Figure 3: External Connections

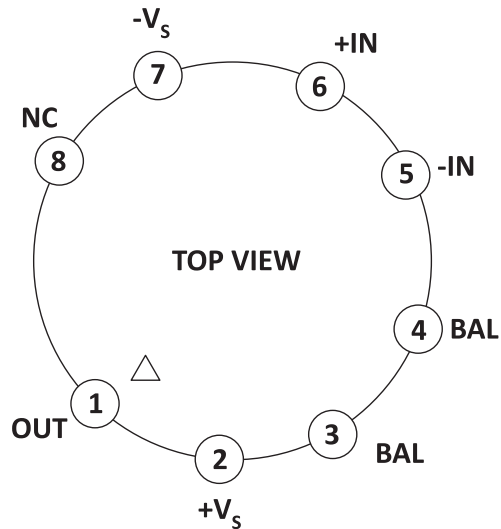

Pin Number	Name	Description
1	OUT	The output. Connect this pin to load and to the feedback resistors.
2	+Vs	The positive supply rail.
3	BAL	Balance Control pin. Adjusts voltage offset. See applicable section.
4	BAL	Balance Control pin. Adjusts voltage offset. See applicable section.
5	-IN	The inverting input.
6	+IN	The non-inverting input.
7	-Vs	The negative supply rail.
8	NC	No connection.

**SPECIFICATIONS**

The power supply voltage for all tests is the TYP rating, unless otherwise noted as a test condition.

**ABSOLUTE MAXIMUM RATINGS**

Parameter	Symbol	Min	Max	Units
Supply Voltage, total	+V <sub>S</sub> to -V <sub>S</sub>		300	V
Output Current, within SOA	I <sub>O</sub>	Internally Limited		
Power Dissipation, continuous @ T <sub>C</sub> = 25°C <sup>1</sup>	P <sub>D</sub>		17.5	W
Input Voltage, differential	V <sub>IN (Diff)</sub>		±300	V
Input Voltage, common mode	V <sub>cm</sub>		±300	V
Temperature, pin solder, 10s max.			350	°C
Temperature, junction	T <sub>J</sub>		175	°C
Temperature Range, storage		-65	+150	°C
Operating Temperature Range, case	T <sub>C</sub>	-55	+125	°C

1. Long term operation at the maximum junction temperature will result in reduced product life. Derate internal power dissipation to achieve high MTTF.

**CAUTION**

The internal substrate contains beryllia (BeO). Do not break the seal. If accidentally broken, do not crush, machine, or subject to temperatures in excess of 850°C to avoid generating toxic fumes.

**INPUT**

Parameter	Test Conditions	PA83			PA83A			Units
		Min	Typ	Max	Min	Typ	Max	
Offset Voltage, initial	T <sub>C</sub> = 25°C		±1.5	±3		±0.5	±1	mV
Offset Voltage vs. Temperature	Full temp range		±10	±25		±5	±10	µV/°C
Offset Voltage vs. Supply	T <sub>C</sub> = 25°C		±0.5			±0.2		µV/V
Offset Voltage vs. Time	T <sub>C</sub> = 25°C		±75			*		µV/vkh
Bias Current, initial <sup>1</sup>	T <sub>C</sub> = 25°C		5	50		3	10	pA
Bias Current vs. Supply	T <sub>C</sub> = 25°C		.01			*		pA/V
Offset Current, initial <sup>1</sup>	T <sub>C</sub> = 25°C		±2.5	±50		±1.5	±10	pA
Offset Current vs. Supply	T <sub>C</sub> = 25°C		±.01			*		pA/V
Input Impedance, DC	T <sub>C</sub> = 25°C		10 <sup>11</sup>			*		Ω
Input Capacitance	Full temp range		6			*		pF
Common Mode Voltage Range <sup>2</sup>	Full temp range	±V <sub>S</sub> -10			*			V
Common Mode Rejection, DC	Full temp range		130			*		dB

1. Doubles for every 10°C of temperature increase.
2. +V<sub>S</sub> and -V<sub>S</sub> denote the positive and negative supply rail respectively. Total V<sub>S</sub> is measured from +V<sub>S</sub> to -V<sub>S</sub>.

**GAIN**

Parameter	Test Conditions	PA83			PA83A			Units
		Min	Typ	Max	Min	Typ	Max	
Open Loop @ 10 Hz	$T_C = 25^\circ\text{C}$ , $R_L = 2\text{ k}\Omega$	96	116		*	*		dB
Unity Gain Crossover Frequency	$T_C = 25^\circ\text{C}$ , $R_L = 2\text{ k}\Omega$		5		3	*		MHz
Power Bandwidth	$T_C = 25^\circ\text{C}$ , $R_L = 10\text{ k}\Omega$		60		40	*		kHz
Phase Margin	Full temp range		60			*		°

**OUTPUT**

Parameter	Test Conditions	PA83			PA83A			Units
		Min	Typ	Max	Min	Typ	Max	
Voltage Swing <sup>1</sup> , full load	Full temp range, $I_O = 75\text{mA}$	$\pm V_S - 10$	$\pm V_S - 5$		*	*		V
Voltage Swing <sup>1</sup>	Full temp range, $I_O = 15\text{mA}$	$\pm V_S - 5$	$\pm V_S - 3$		*	*		V
Current, peak	$T_C = 25^\circ\text{C}$	75			*			mA
Current, short circuit	$T_C = 25^\circ\text{C}$		100			*		mA
Slew Rate <sup>2</sup>	$T_C = 25^\circ\text{C}$ , $R_L = 2\text{ k}\Omega$	20	30		*	*		V/ $\mu\text{s}$
Capacitive Load, unity gain	Full temp range			10			*	nF
Capacitive Load, gain > 4	Full temp range			SOA			*	$\mu\text{F}$
Settling Time to 0.1%	$T_C = 25^\circ\text{C}$ , $R_L = 2\text{ k}\Omega$ , 10V step		12			*		$\mu\text{s}$

1.  $+V_S$  and  $-V_S$  denote the positive and negative supply rail respectively. Total  $V_S$  is measured from  $+V_S$  to  $-V_S$ .
2. Signal slew rates at pins 5 and 6 must be limited to less than 1V/ns to avoid damage. When faster waveforms are unavoidable, resistors in series with those pins, limiting current to 150mA will protect the amplifier from damage.

**POWER SUPPLY**

Parameter	Test Conditions	PA83			PA83A			Units
		Min	Typ	Max	Min	Typ	Max	
Voltage	$T_C = -55$ to $125^\circ\text{C}$	$\pm 15$	$\pm 150$	$\pm 150$	*	*	*	V
Current, quiescent	$T_C = 25^\circ\text{C}$		6	8.5		*	*	mA

**THERMAL**

Parameter	Test Conditions	PA83			PA83A			Units
		Min	Typ	Max	Min	Typ	Max	
Resistance, AC, junction to case <sup>1</sup>	F > 60 Hz		4.26			*		°C/W
Resistance, DC, junction to case	F < 60 Hz		6.22	8.57		*	*	°C/W
Resistance, case to air			30			*		°C/W
Temperature Range, case	Meets full range specs	-25		+85	*		*	°C

1. Rating applies if the output current alternates between both output transistors at a rate faster than 60 Hz.

**Note:** \* The specification of PA83A is identical to the specification for PA83 in applicable column to the left.

TYPICAL PERFORMANCE GRAPHS

Figure 4: Power Derating

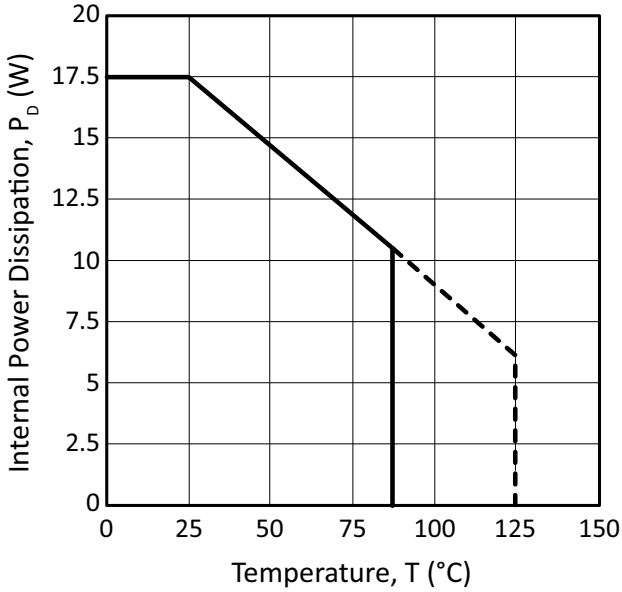

Figure 5: Current Limit

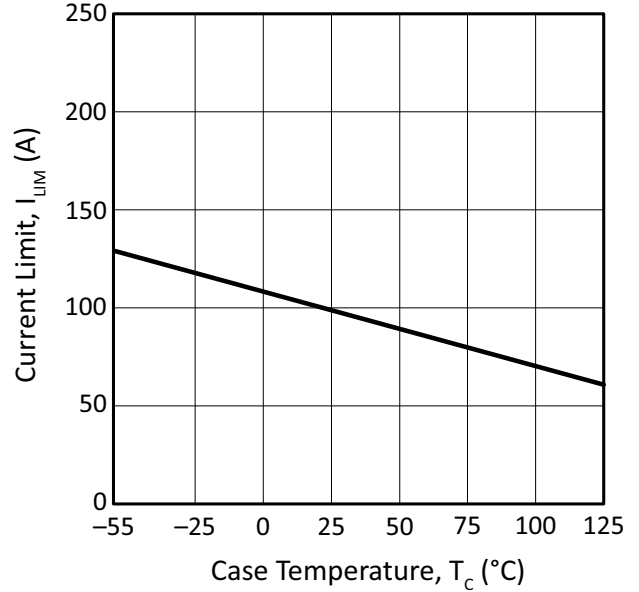

Figure 6: Small Signal Response

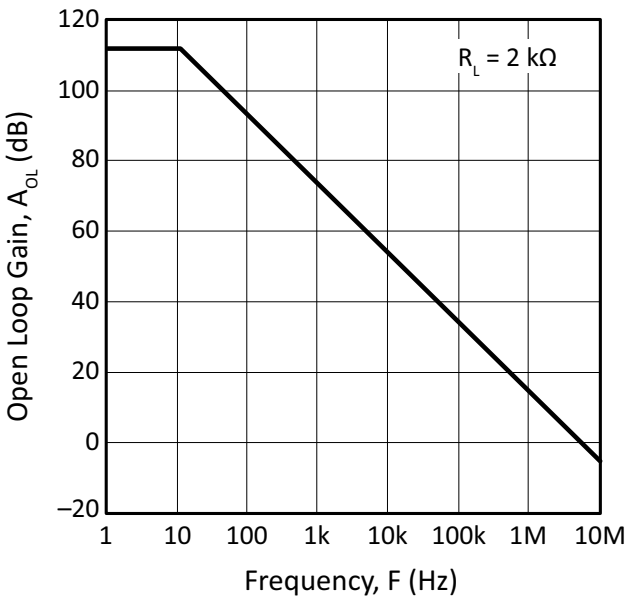

Figure 7: Phase Response

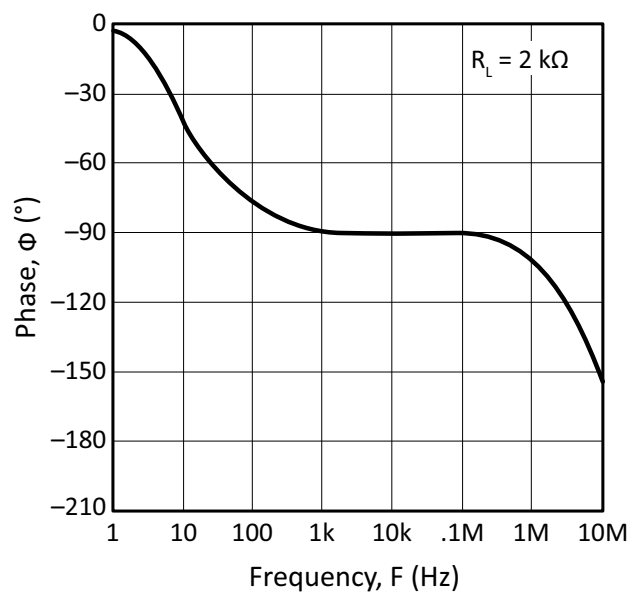

Figure 8: Output Voltage Swing

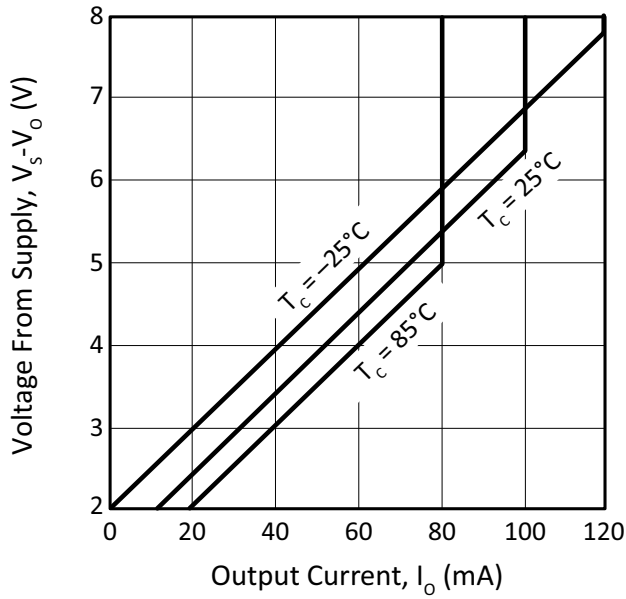

Figure 9: Power Response

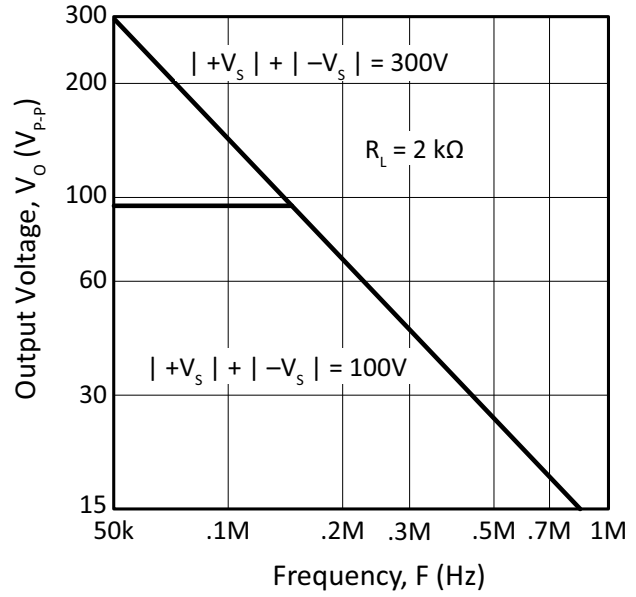

Figure 10: Pulse Response

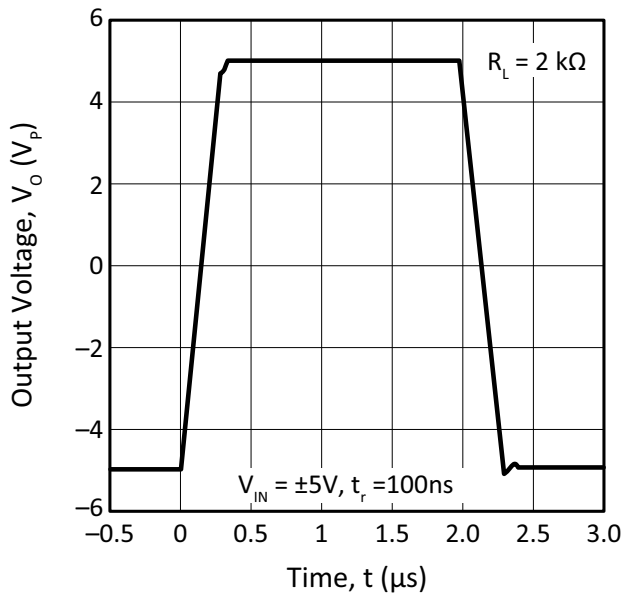

Figure 11: Slew Rate vs. Supply

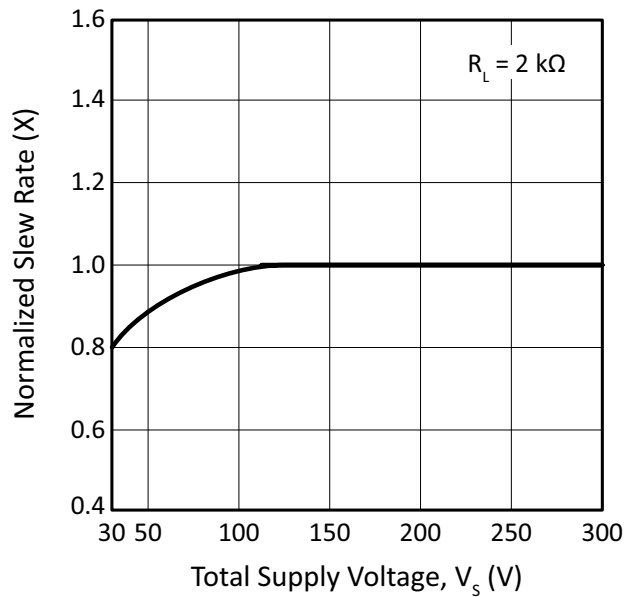



Figure 12: Input Noise

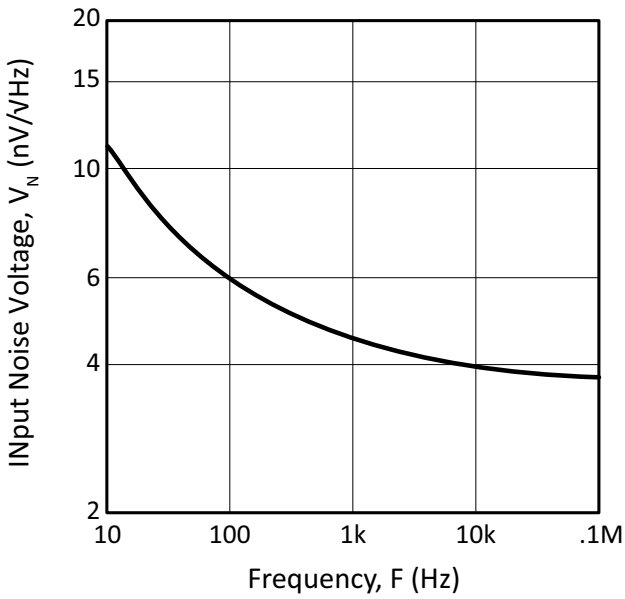

Figure 13: Common Mode Rejection

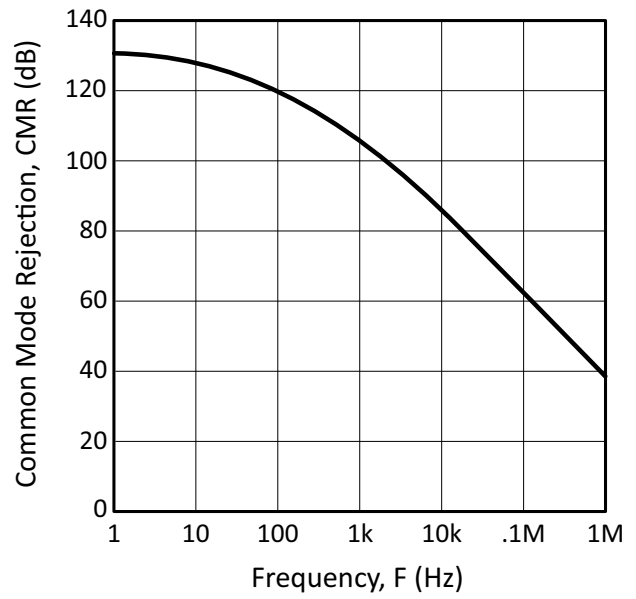

Figure 14: Power Supply Rejection

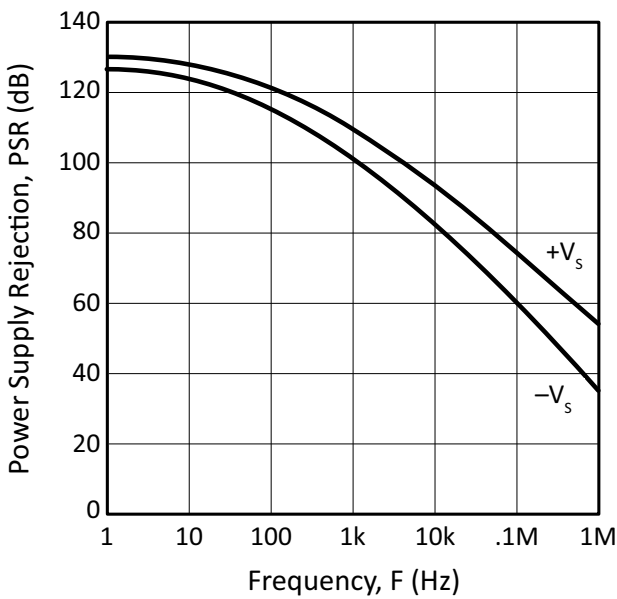
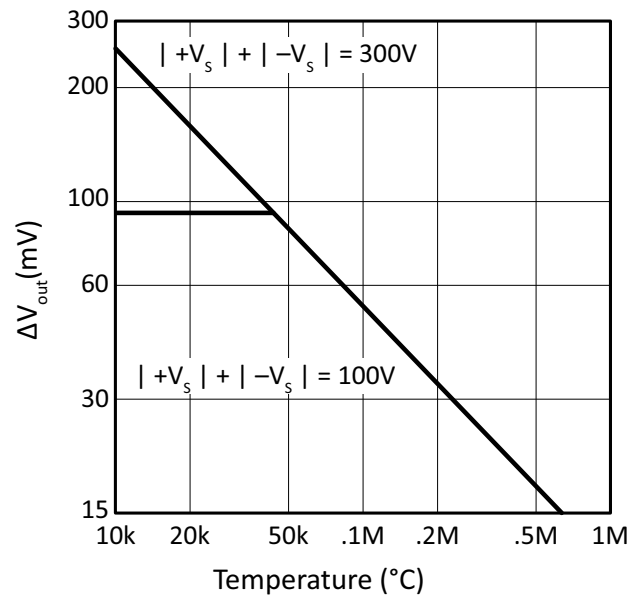

Figure 15: Common Mode Voltage



**SAFE OPERATING AREA (SOA)**

The bipolar output stage of this high voltage amplifier has two distinct limitations.

1. The internal current limit, which limits maximum available output current.
2. The second breakdown effect, which occurs whenever the simultaneous collector current and collector-emitter voltage exceed specified limits.

The SOA curves combine the effect of these limits. For a given application, the direction and magnitude of the output current should be calculated or measured and checked against the SOA curves. This is simple for resistive loads but more complex for reactive and EMF generating loads. However, the following guidelines may save extensive analytical efforts:

1. The following capacitive and inductive loads are safe:

$\pm V_s$	C(MAX)	L(MAX)
150V	0.7 F	1.5 H
125V	2.0 $\mu$ F	2.5 H
100V	5.0 $\mu$ F	6.0 H
75V	60 $\mu$ F	30 H
50V	ALL	ALL

2. Short circuits to ground are safe with dual supplies up to 120V or single supplies up to 120V.
3. Short circuits to the supply rails are safe with total supply voltages up to 120V, e.g.  $\pm 60V$ .
4. The output stage is protected against transient flyback. However, for protection against sustained, high energy flyback, external fast-recovery diodes should be used.

**Figure 16: SOA**

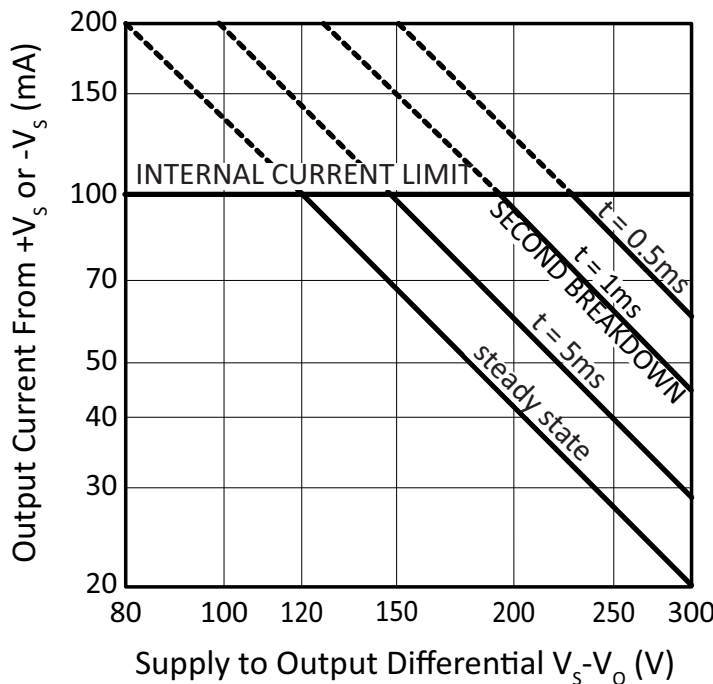

## GENERAL

Please read Application Note 1 “General Operating Considerations” which covers stability, supplies, heat sinking, mounting, current limit, SOA interpretation, and specification interpretation. Visit [www.apexanalog.com](http://www.apexanalog.com) for Apex Microtechnology’s complete Application Notes library, Technical Seminar Workbook, and Evaluation Kits.

## TYPICAL APPLICATION

While piezo electric transducers present a complex impedance, they are often primarily capacitive at useful frequencies. Due to this capacitance, the speed limitation for a given transducer/amplifier combination may well stem from limited current drive rather than power bandwidth restrictions. With its drive capability of 75mA, the PA83 can drive transducers having up to 2nF of capacitance at 40 kHz at maximum output voltage. In the event the transducer may be subject to shock or vibration, flyback diodes, voltage clamps or other protection networks must be added to protect the amplifier from high voltages which may be generated.

Figure 17: Typical Application (Simple Piezo Electric Transducer Drive)

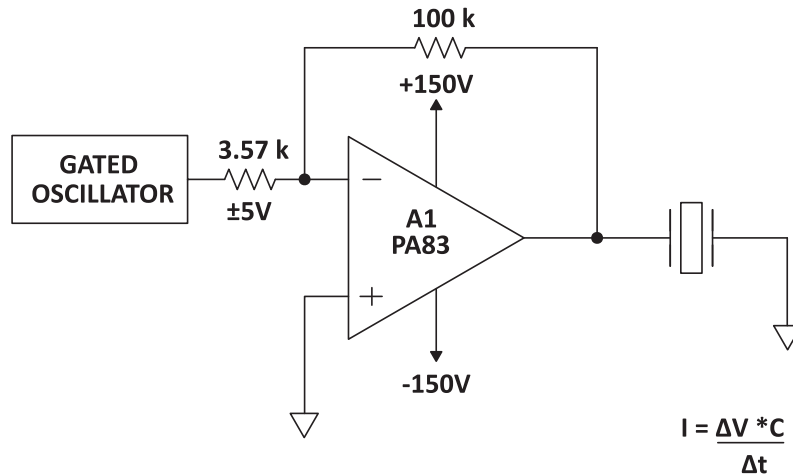

## INDUCTIVE LOADS

Two external diodes as shown in Figure 18, are required to protect these amplifiers against flyback (kick-back) pulses exceeding the supply voltages of the amplifier when driving inductive loads. For component selection, these external diodes must be very quick, such as ultra fast recovery diodes with no more than 200 nanoseconds of reverse recovery time. Be sure the diode voltage rating is greater than the total of both supplies. The diode will turn on to divert the flyback energy into the supply rails thus protecting the output transistors from destruction due to reverse bias.

A note of caution about the supply. The energy of the flyback pulse must be absorbed by the power supply. As a result, a transient will be superimposed on the supply voltage, the magnitude of the transient being a function of its transient impedance and current sinking capability. If the supply voltage plus transient exceeds the maximum supply rating or if the AC impedance of the supply is unknown, it is best to clamp the output and the supply with a zener diode to absorb the transient.

Figure 18: Protection, Inductive Load

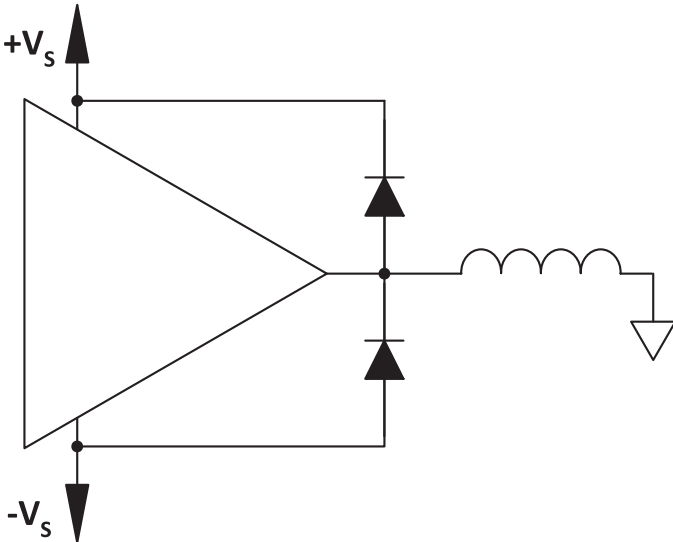

**PACKAGE OPTIONS**

Part Number	Apex Package Style	Description
PA83	CE	8-pin TO-3
PA83A	CE	8-pin TO-3

**PACKAGE STYLE CE**

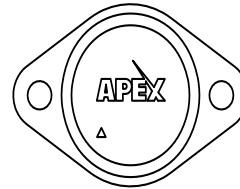
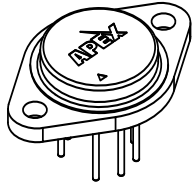

**Ordinate dimensions for CAD layout**

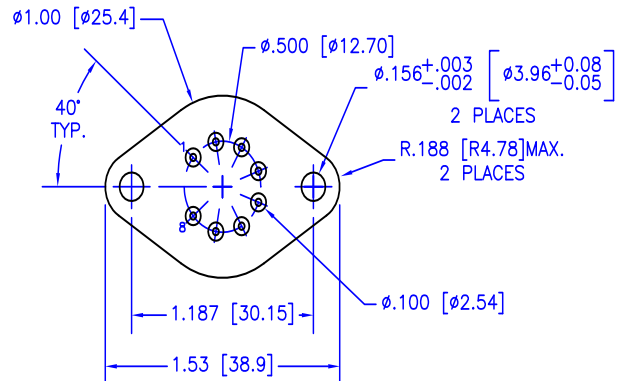
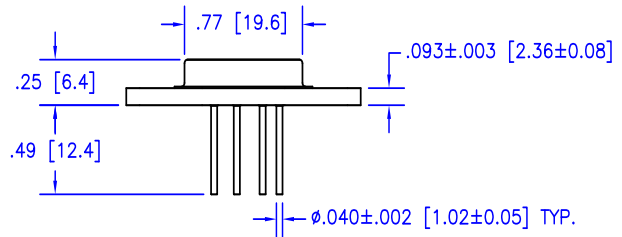
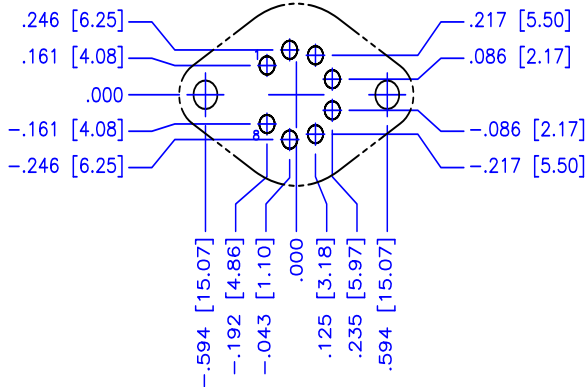

**NOTES:**

1. Dimensions are inches & [mm].
2. Triangle printed on lid denotes pin 1.
3. Header flatness within pin circle is .0005" TIR, max.
4. Header flatness between mounting holes is .0015" TIR, max.
5. Standard pin material: Solderable nickel-plated Alloy 52.
6. Header material: Nickel-plated cold-rolled steel.
7. Welded hermetic package seal
8. Isolation: 500 VDC any pin to case.
9. Package weight: .53 oz [15 g]