

High Voltage Power Operational Amplifiers



FEATURES

- 1140V P-P Signal Output
- Wide Supply Range — $\pm 75V$ to $\pm 600V$
- Programmable Current Limit
- 75 mA Continuous Output Current
- Hermetically Sealed Package
- Input Protection



APPLICATIONS

- Piezoelectric Positioning
- High Voltage Instrumentation
- Electrostatic Deflection
- Semiconductor Testing

DESCRIPTION

The PA89 is an ultra high voltage, MOSFET operational amplifier designed for output currents up to 75 mA. Output voltages can swing over 1000V p-p. The safe operating area (SOA) has no second breakdown limitations and can be observed with all types of loads by choosing an appropriate current limiting resistor. High accuracy is achieved with a cascode input circuit configuration and 120dB open loop gain. All internal biasing is referenced to a bootstrapped zener-MOSFET current source, giving the PA89 a wide supply range and excellent supply rejection. The MOSFET output stage is biased for class A/B linear operation. External compensation provides user flexibility. The PA89 hermetic seal is 100% tested to the requirements of MIL-STD-883 method 1014 for fine and gross leak.

This hybrid integrated circuit utilizes a Beryllia (BeO) substrate, thick film resistors, ceramic capacitors and semiconductor chips to maximize reliability, minimize size and give top performance. Ultrasonically bonded aluminum wires provide reliable interconnections at all operating temperatures. The MO-127 High Voltage, Power Dip™ package is hermetically sealed and electrically isolated. The use of compressible thermal washers will void the product warranty.

EQUIVALENT SCHEMATIC

Figure 1: Equivalent Schematic

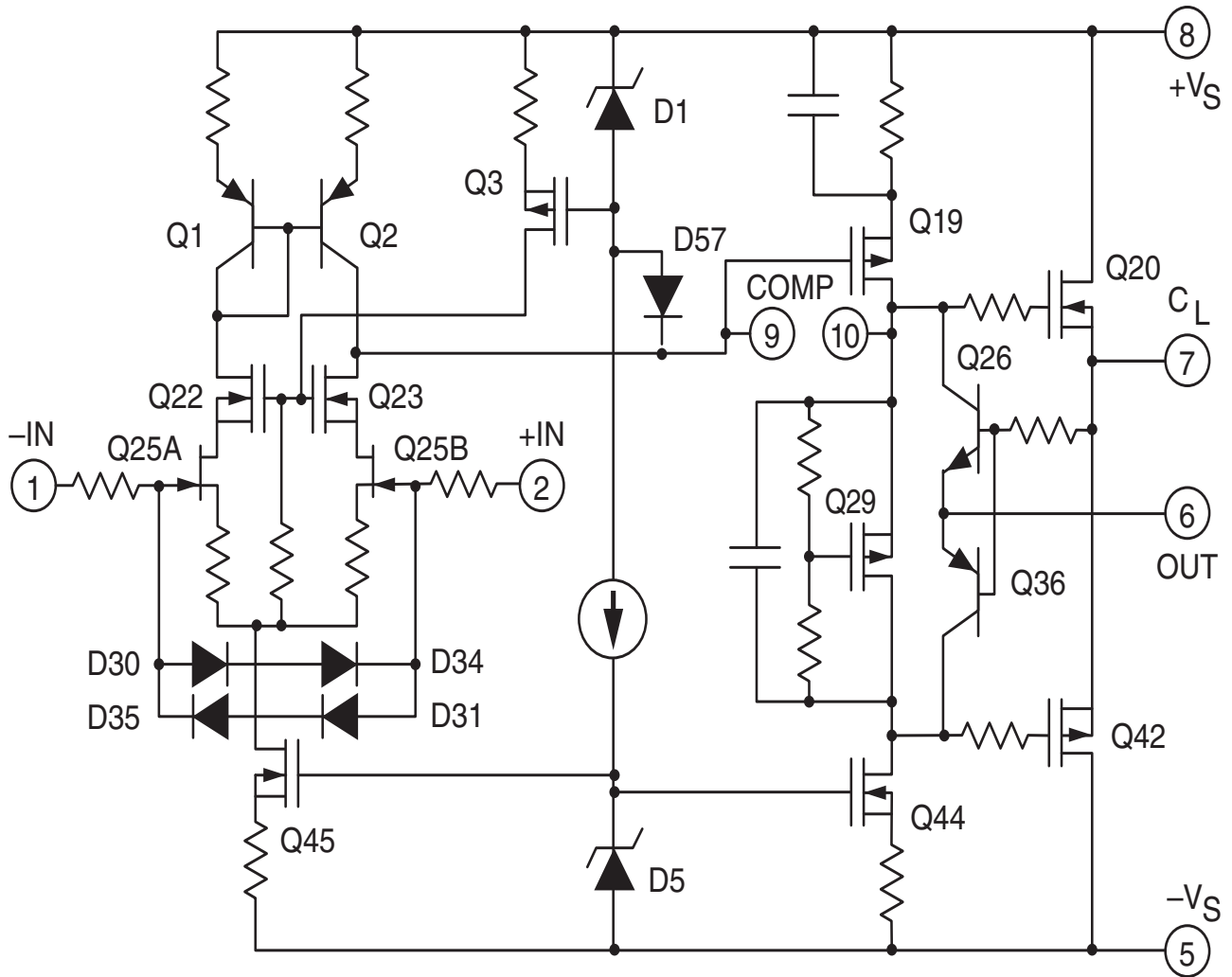

TYPICAL CONNECTION

Figure 2: Typical Connection

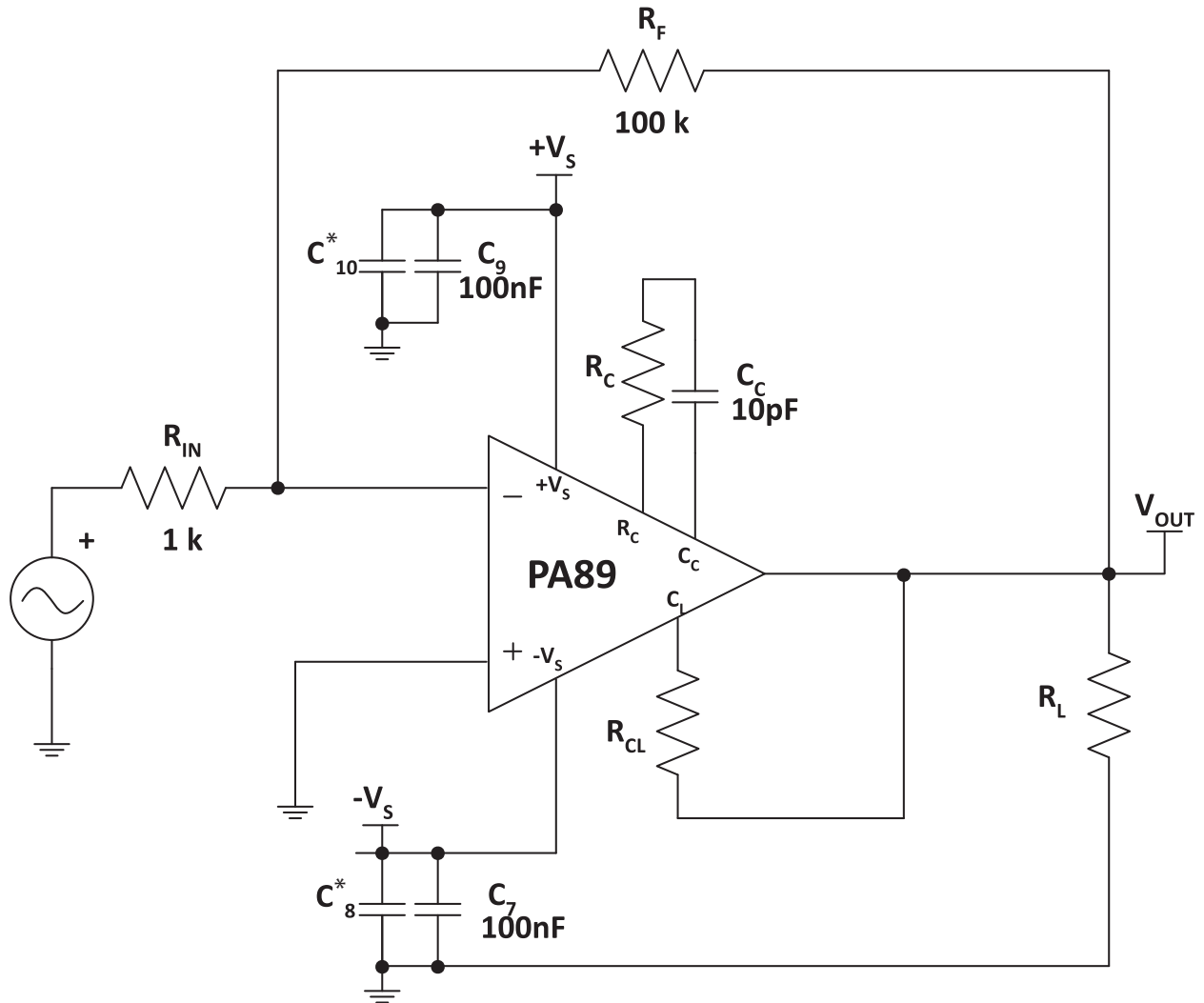

Note: *Bulk bypass capacitors use 10 μ F per Amp of output current.

PINOUT AND DESCRIPTION TABLE

Figure 3: External Connections

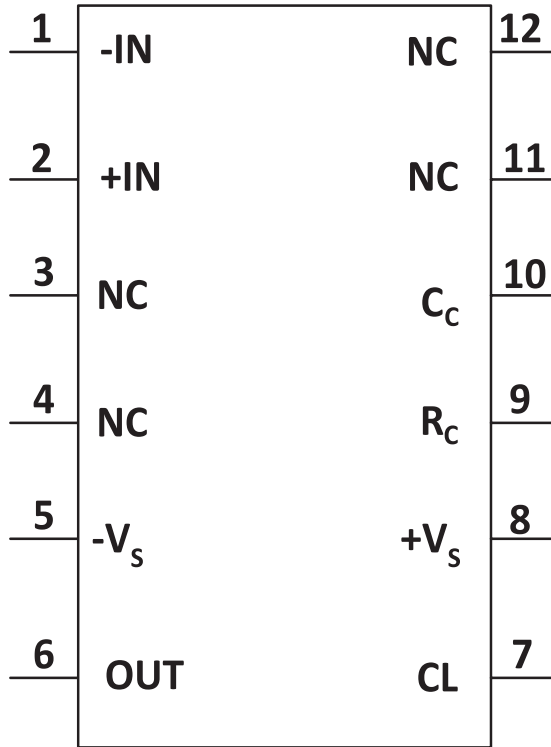

Pin Number	Name	Description
1	-IN	The inverting input.
2	+IN	The non-inverting input.
5	-Vs	The negative supply rail.
6	OUT	The output. Connect this pin to load and to the feedback resistors.
7	CL	Connect to the current limit resistor. Output Current flows into/out of these pins through R _{CL} . The output pin and the load are connected to the other side of R _{CL} .
8	+Vs	The positive supply rail.
9	RC	Compensation resistor connection. Select value based on Phase Compensation. See applicable section.
10	CC	Compensation capacitor connection. Select value based on Phase Compensation. See applicable section.
3, 4, 11, 12	NC	No connection.

CHARACTERISTICS AND SPECIFICATIONS

Unless otherwise noted: $T_C = 25^\circ\text{C}$, $C_C = 68\text{pF}$, $R_C = 220\ \Omega$, and $V_S = \pm 500\text{V}$. Input parameters for bias currents and offset voltage are \pm values given.

ABSOLUTE MAXIMUM RATINGS

Parameter	Symbol	Min	Max	Units
Supply Voltage, total	$+V_S$ to $-V_S$		1200	V
Output Current, source, within SOA	I_O		100	mA
Power Dissipation, continuous @ $T_C = 25^\circ\text{C}$	P_D		40	W
Input Voltage, differential	V_{IN} (Diff)		± 25	V
Input Voltage, common mode	V_{cm}		$\pm V_S - 50\text{V}$	V
Temperature, pin solder, 10s max.			350	$^\circ\text{C}$
Temperature, junction ¹	T_J		150	$^\circ\text{C}$
Temperature, storage		-65	+150	$^\circ\text{C}$
Operating Temperature Range, case	T_C	-55	+125	$^\circ\text{C}$

1. Long term operation at the maximum junction temperature will result in reduced product life. Derate internal power dissipation to achieve high MTTF.

CAUTION

The PA89 is constructed from MOSFET transistors. ESD handling procedures must be observed. The internal substrate contains beryllia (BeO). Do not break the seal. If accidentally broken, do not crush, machine, or subject to temperatures in excess of 850°C to avoid generating toxic fumes.

INPUT

Parameter	Test Conditions	PA89			PA89A			Units
		Min	Typ	Max	Min	Typ	Max	
Offset Voltage, initial	$V_S = \pm 150V$		0.5	2		0.25	0.74	mV
Offset Voltage vs. temperature	Full temp range		10	30		5	10	$\mu V/^\circ C$
Offset Voltage vs. supply			7			*		$\mu V/V$
Offset Voltage vs. time			75			*		$\mu V/kh$
Bias Current, initial ¹	$V_S = \pm 150V$		5	50		3	15	pA
Bias Current vs. supply			0.01			*		pA/V
Offset Current, initial ¹	$V_S = \pm 150V$		5	50		3	30	pA
Input Impedance, DC			10^{11}			*		Ω
Input Capacitance			4			*		pF
Common Mode Voltage Range ²	Full temp range	$\pm V_S - 50$			*			V
Common Mode Rejection, DC	Full temp range, $V_{CM} = \pm 90V$	96	110		*	*		dB
Input Noise	10 kHz BW, $R_S = 10 k$, $C_C = 15pF$		4			*		μV RMS

1. Doubles for every 10 °C of temperature increase.
2. + V_S and - V_S denote the positive and negative power supply rail respectively.

GAIN

Parameter	Test Conditions	PA89			PA89A			Units
		Min	Typ	Max	Min	Typ	Max	
Open Loop Gain at 15Hz	$R_L = 10 k\Omega$, $C_C = 15pF$	108	120		*	*		dB
Gain Bandwidth Product	$R_L = 10 k\Omega$, $C_C = 15pF$, $A_V = 100$		10			*		MHz
Power Bandwidth	$R_L = 10 k\Omega$, $C_C = 15pF$, $V_O = 500V$ p-p		5			*		kHz
Phase Margin	Full temp range, $A_V = 10$		60			*		°

OUTPUT

Parameter	Test Conditions	PA89			PA89A			Units
		Min	Typ	Max	Min	Typ	Max	
Voltage Swing ¹	$I_O = 75\text{mA}$	$\pm V_S - 45$	$\pm V_S - 30$		*	*		V
Voltage Swing ¹	Full temp range, $I_O = 20\text{mA}$	$\pm V_S - 20$	$\pm V_S - 12$		*	*		V
Current, continuous	Full temp range	75			*			mA
Slew Rate	$C_C = 15\text{pF}, A_V = 100$	12	16		*	*		V/ μs
Capacitive Load, $A_V = 10$	Full temp range			1			*	nF
Capacitive Load, $A_V > 10$	Full temp range			SOA			*	
Settling Time to 0.1%	$R_L = 10\text{ k}\Omega$, 10V step, $A_V = 10$		2			*		μs

1. $+V_S$ and $-V_S$ denote the positive and negative supply rail respectively.

POWER SUPPLY

Parameter	Test Conditions	PA89			PA89A			Units
		Min	Typ	Max	Min	Typ	Max	
Voltage, V_S ¹	Full temp range	± 75	± 500	± 600	*	*	*	V
Current, quiescent			4.8	6.0		*	*	mA

1. $+V_S$ and $-V_S$ denote the positive and negative supply rail respectively.

THERMAL

Parameter	Test Conditions	PA89			PA89A			Units
		Min	Typ	Max	Min	Typ	Max	
Resistance, AC, junction to case ¹	Full temp range, $F > 60\text{ Hz}$		2.1	2.3		*	*	$^{\circ}\text{C}/\text{W}$
Resistance, DC, junction to case	Full temp range, $F < 60\text{ Hz}$		3.3	3.5		*	*	$^{\circ}\text{C}/\text{W}$
Resistance, junction to air	Full temp range		15			*		$^{\circ}\text{C}/\text{W}$
Temperature Range, case	Meets full range specifications	-25		+85	*		*	$^{\circ}\text{C}$

1. Rating applies only if the output current alternates between both output transistors at a rate faster than 60 Hz.

Note: *The specification of PA89A is identical to the specification for PA89 in applicable column to the left.

TYPICAL PERFORMANCE GRAPHS

Figure 4: Power Derating

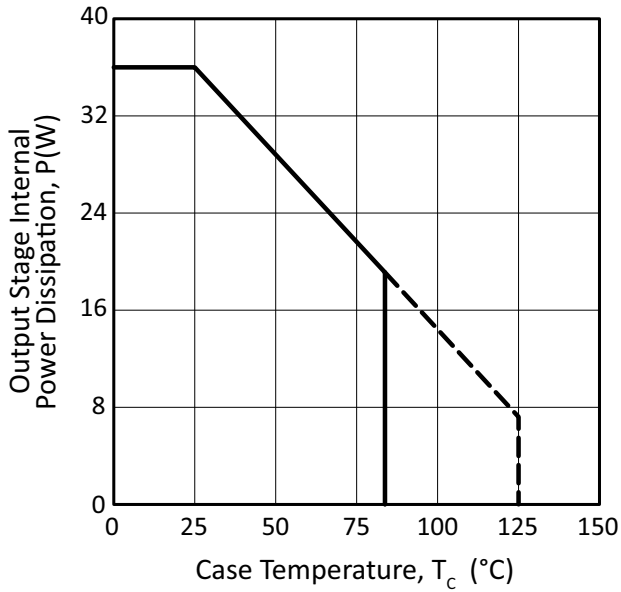

Figure 5: Quiescent Current

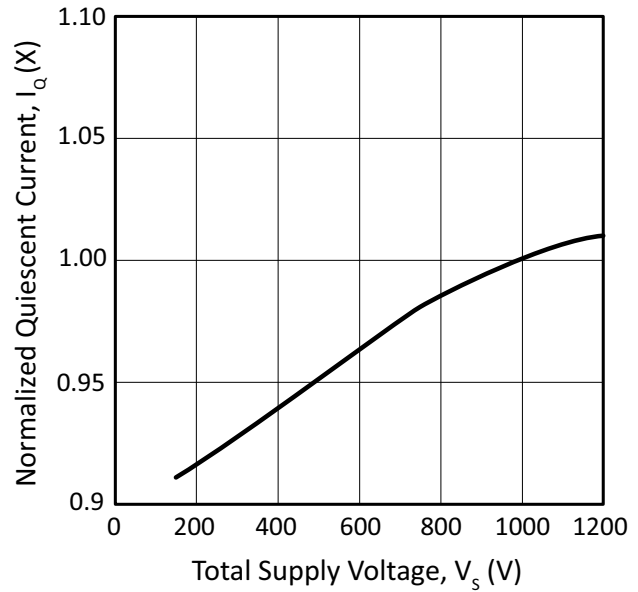

Figure 6: Small Signal Response

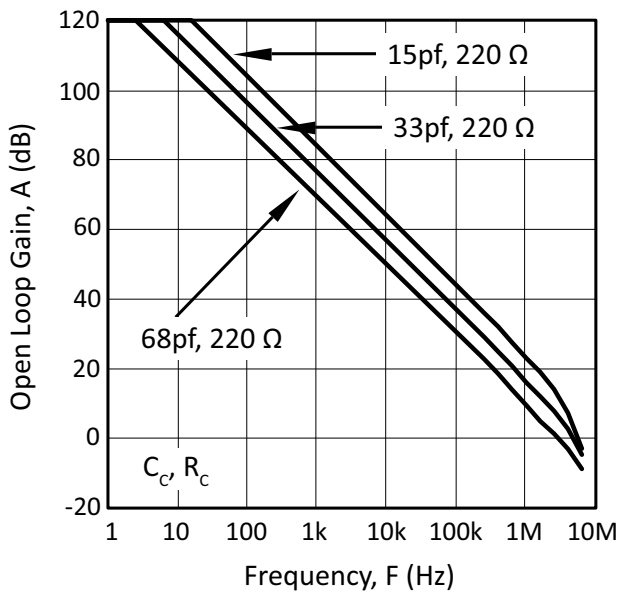

Figure 7: Phase Response

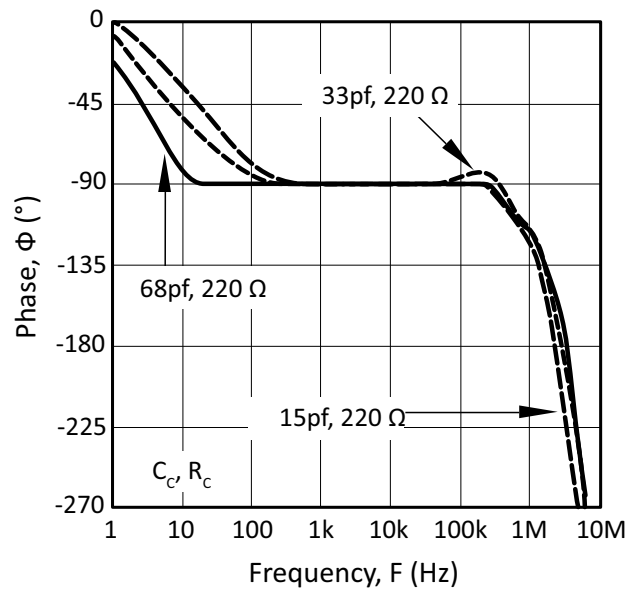

Figure 8: Output Voltage Swing

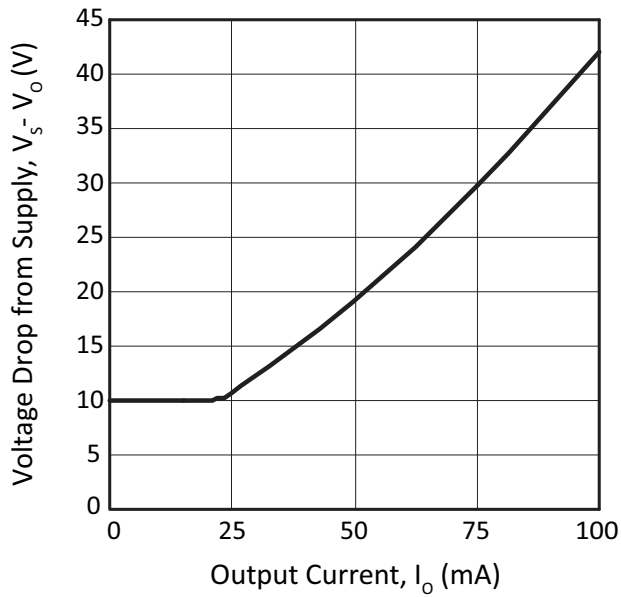

Figure 9: Power Response

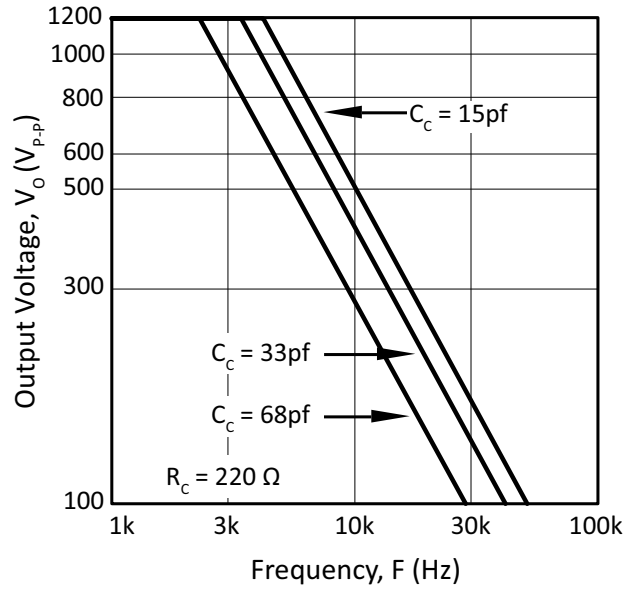

Figure 10: Slew Rate vs. Comp

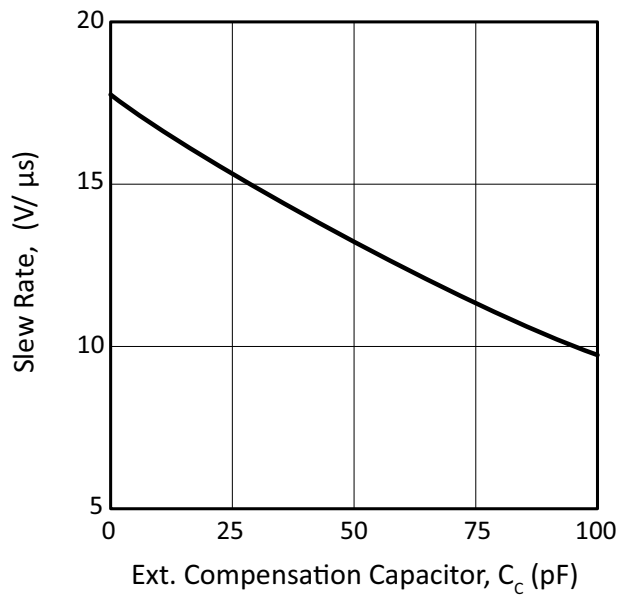

Figure 11: Harmonic Distortion

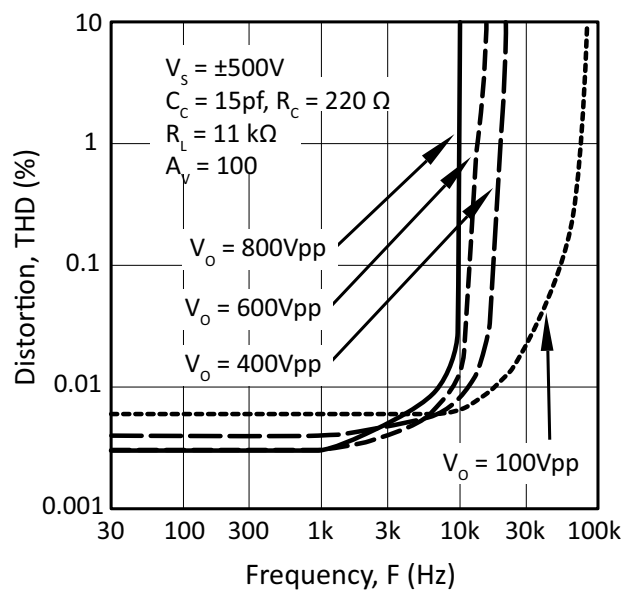

Figure 12: Input Noise Voltage

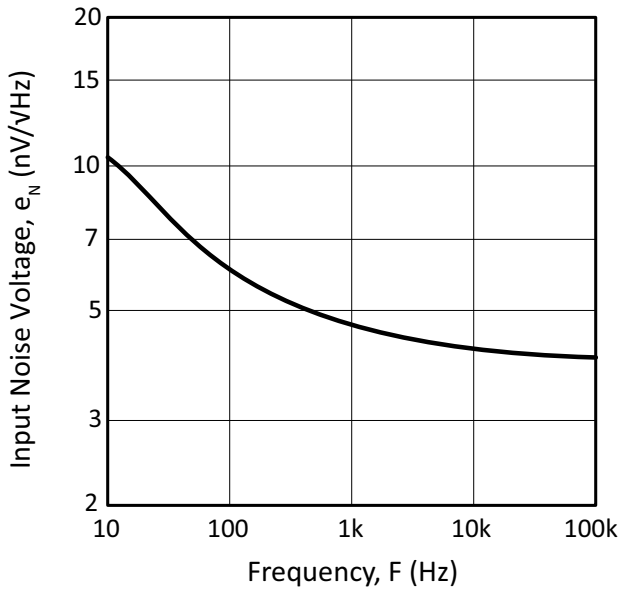

Figure 13: Common Mode Rejection

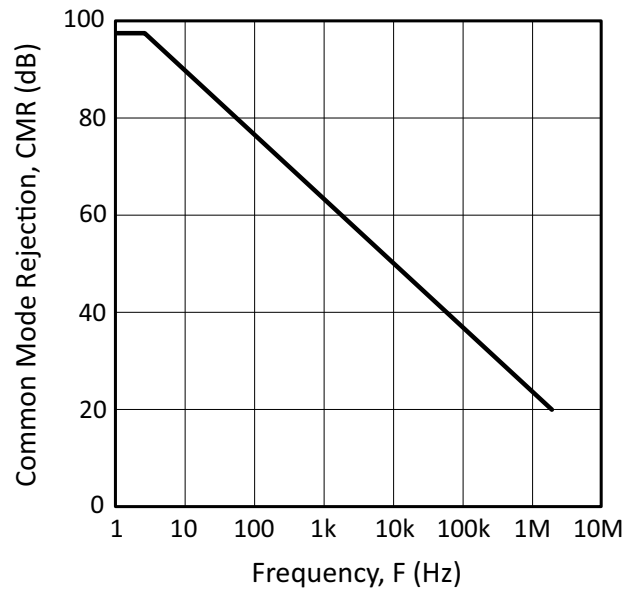

Figure 14: Power Supply Rejection

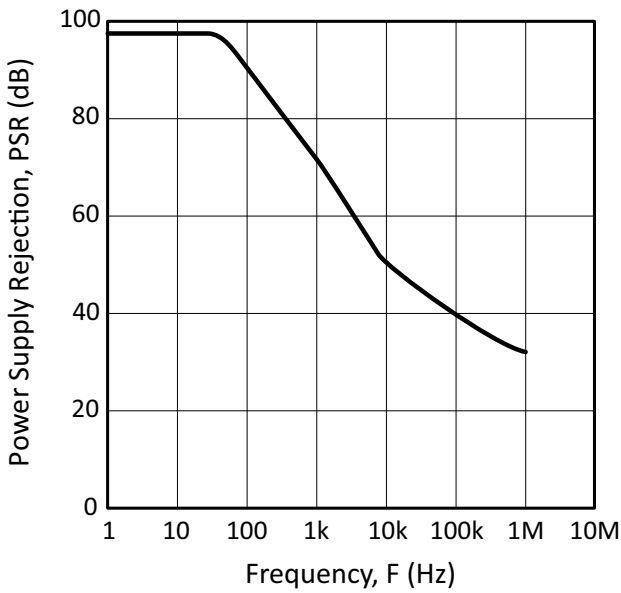
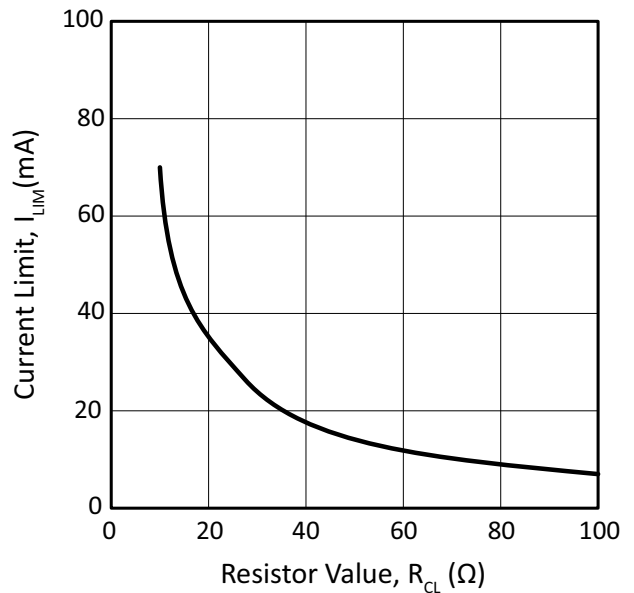

Figure 15: Current Limit



SAFE OPERATING AREA (SOA)

The safe operating area curves define the maximum additional internal power dissipation the amplifier can tolerate when it produces the necessary output to drive an external load. This is not the same as the absolute maximum internal power dissipation listed elsewhere in the specification since the quiescent power dissipation is significant compared to the total.

The MOSFET output stage of this power operational amplifier has two distinct limitations:

1. The current handling capability of the MOSFET geometry and the wire bonds.
2. The junction temperature of the output MOSFETs.

Note: The output stage is protected against transient flyback. However, for protection against sustained, high energy flyback, external fast-recovery diodes should be used.

Figure 16: SOA

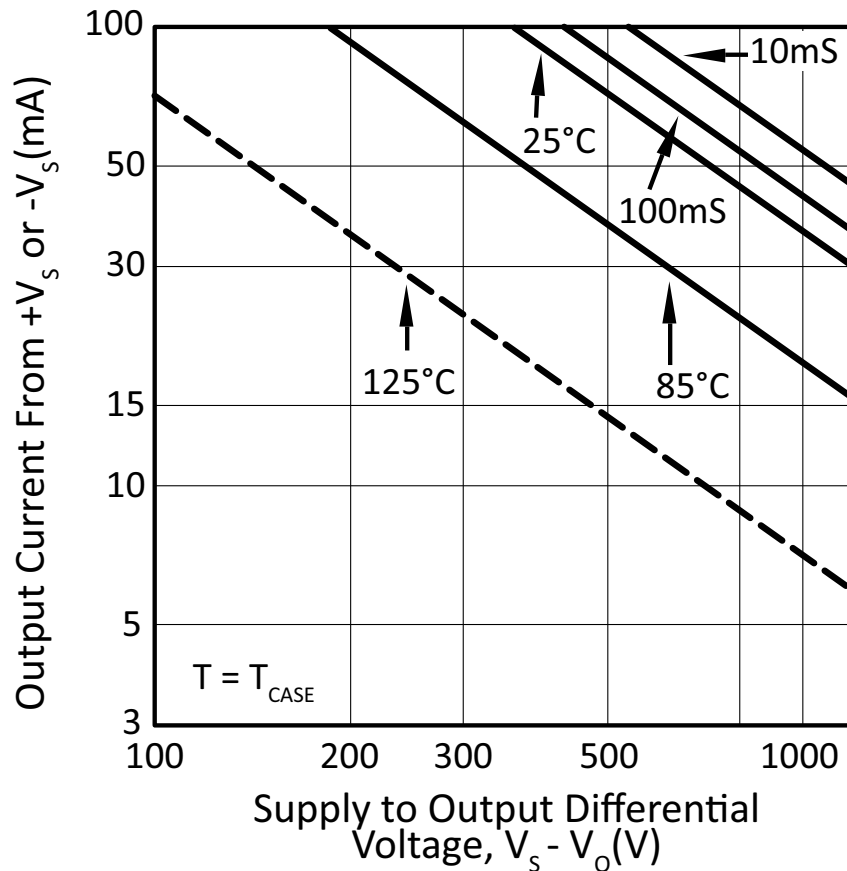

GENERAL

Please read Application Note 1 “General Operating Considerations” which covers stability, supplies, heat sinking, mounting, current limit, SOA interpretation, and specification interpretation. Visit www.apexanalog.com for Apex Microtechnology’s complete Application Notes library, Technical Seminar Workbook, and Evaluation Kits.

TYPICAL APPLICATION

Ultra-high voltage capability combined with the bridge amplifier configuration makes it possible to develop +/-1000 volt peak swings across a piezo element. A high gain of -50 for A1 insures stability with the capacitive load, while “noise-gain” compensation R_n and C_n on A2 insure the stability of A2 by operating in a noise gain of 50.

Figure 17: Typical Application

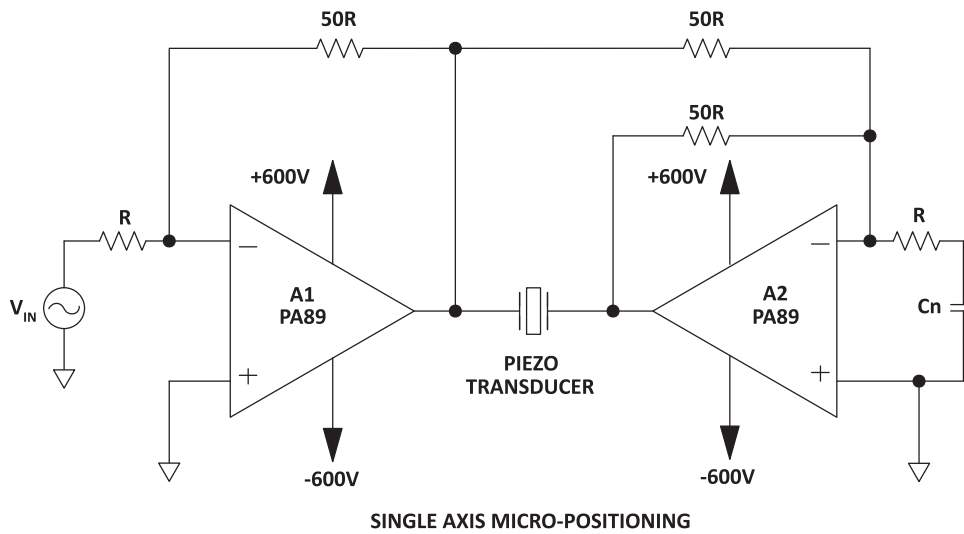

PHASE COMPENSATION

Gain	C_C	R_C
1	470pF	470 Ω
10	68pF	220 Ω
15	33pF	220 Ω
100	15pF	220 Ω

Note: C_C must be rated for full supply voltage $-V_s$ to $+V_s$. See details under “EXTERNAL COMPONENTS”.

STABILITY

Although the PA89 can be operated at unity gain, maximum slew rate and bandwidth performance was designed to be obtained at gains of 10 or more. Use the small signal response and phase response graphs as a guide. In applications where gains of less than 10 are required, use noise gain compensation to increase the phase margin of the application circuit as illustrated in the typical application drawing.

CURRENT LIMIT

For proper operation the current limit resistor (R_{CL}) must be connected as shown in the external connection diagram. The minimum value is 3.5 Ω , however for optimum reliability the resistor value should be set as high as possible. The value is calculated as follows with the maximum practical value of 150 Ω .

$$R_{CL}(\Omega) = \frac{0.7V}{I_{LIM}(A)}$$

When setting the value for R_{CL} allow for the load current as well as the current in the feedback resistor. Also allow for the temperature coefficient of the current limit which is approximately -0.3% /°C of case temperature rise.

EXTERNAL COMPONENTS

The very high operating voltages of the PA89 demand consideration of two component specifications rarely of concern in building op amp circuits: voltage rating and voltage coefficient.

The compensation capacitance C_C must be rated for the full supply voltage range. For example, with supply voltages of $\pm 500V$ the possible voltage swing across C_C is 1000V. In addition, a voltage coefficient less than 100PPM is recommended to maintain the capacitance variation to less than 5% for this example. It is strongly recommended to use the highest quality capacitor possible rated at least twice the total supply voltage range.

Of equal importance are the voltage rating and voltage coefficient of the gain setting resistances. Typical voltage ratings of low wattage resistors are 150 to 250V. In the above example 1000V could appear across the feedback resistor. This would require several resistors in series to obtain the proper voltage rating. Low voltage coefficient resistors will insure good gain linearity. The wattage rating of the feedback resistor is also of concern. A 1 Megaohm feedback resistor could easily develop 1 watt of power dissipation.

Though high voltage rated resistors can be obtained, a 1 Megaohm feedback resistor comprised of five 200 k Ω , 1/4 watt metal film resistors in series will produce the proper voltage rating, voltage coefficient and wattage rating.

POWER SUPPLY PROTECTION

Unidirectional zener diode transient absorbers are recommended as protection on the supply pins. The zeners clamp transients to voltages within the power supply rating and also clamp power supply reversals to ground. Whether the zeners are used or not, the system power supply should be evaluated for transient performance including power-on overshoot and power-off polarity reversals as well as line regulation.

Conditions which can cause open circuits or polarity reversals on either power supply rail should be avoided or protected against. Reversals or opens on the negative supply rail is known to induce input stage failure. Unidirectional transzors prevent this, and it is desirable that they be both electrically and physically as close to the amplifier as possible.

CAUTIONS

The operating voltages of the PA89 are potentially lethal. During circuit design, develop a functioning circuit at the lowest possible voltages. Clip test leads should be used for "hands off" measurements while troubleshooting.

PACKAGE DESIGN

PACKAGE STYLE DC

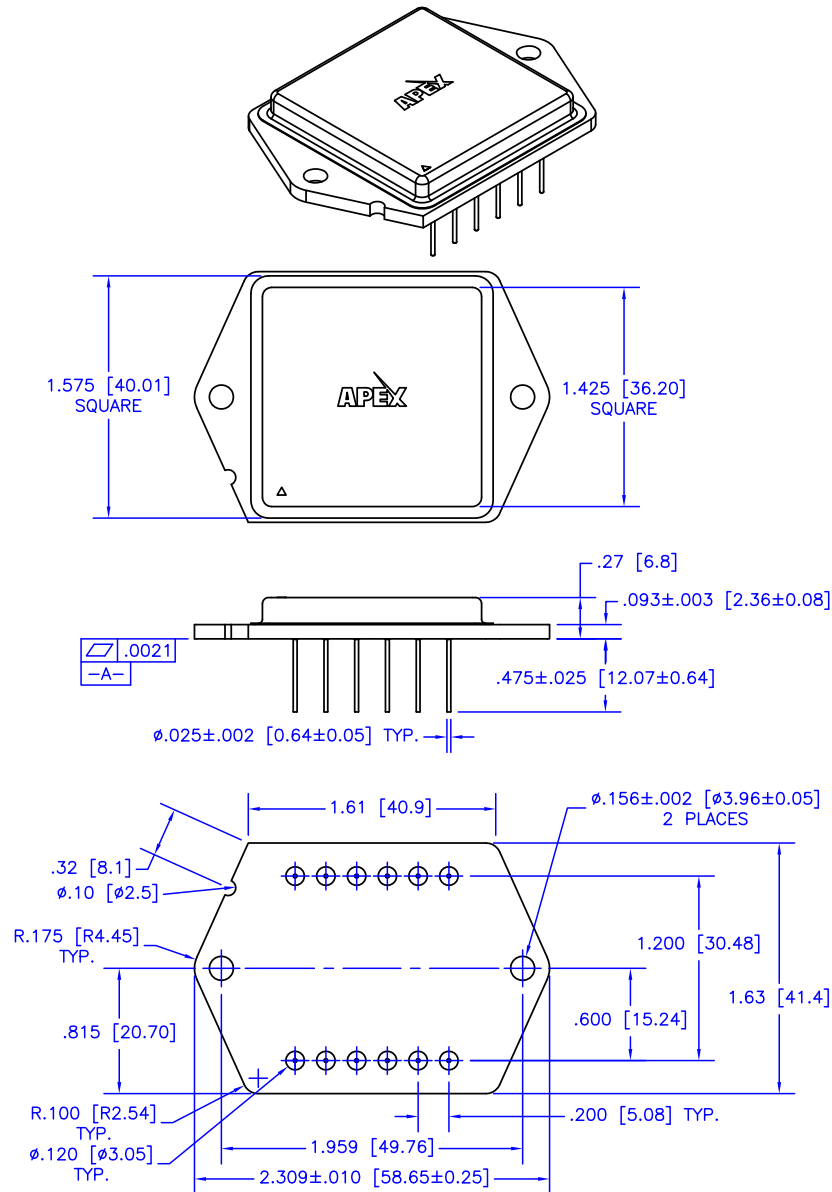

NOTES:

1. Dimensions are in inches & [mm].
2. Triangle on lid and notch in header denote pin 1.
3. Header material: Nickel-plated CRS
4. Lid material: Solid nickel
5. Pin material: Solderable nickel-plated Alloy 52
6. Welded hermetic package seal
7. Isolation: 1200 VDC any pin to case
8. Package weight: 1.87 oz [53 g]