

Power Operational Amplifiers

RoHS
COMPLIANT

FEATURES

- High Voltage — 450V ($\pm 225V$)
- High Slew Rate — $1000V/\mu s$
- High Output Current — 200mA

APPLICATIONS

- High Voltage Instrumentation
- Piezo Transducer Excitation
- Programmable Power Supplies Up To 430V
- Electrostatic Transducers & Deflection



DESCRIPTION

The PA98 is a 450V high-power operational amplifier. This high voltage amplifier utilizes a MOSFET output stage and has a power bandwidth of up to 500 kHz. When operating within a safe operating area, the PA98 has a maximum continuous current of 200mA. Output voltages can swing up to $\pm 215V$ with a dual supply and up to +440 volts with a single supply. The safe operating area (SOA) has no second breakdown limitations and can be observed with all types of loads by choosing an appropriate current limiting resistor. High accuracy is achieved with a cascode input circuit configuration. All internal biasing is referenced to a bootstrapped zener-MOSFET current source. As a result, the PA98 features an unprecedented supply range and excellent supply rejection. The MOSFET output stage is biased on for linear operation. External compensation provides user flexibility. This hybrid circuit utilizes thick film (cermet) resistors, ceramic capacitors and silicon semiconductors. This process is used to maximize reliability, minimize size and provide exceptional performance. Ultrasonically bonded aluminum wires provide reliable interconnections over the full temperature range of the device. The Power SIP is electrically isolated.

Figure 1: Equivalent Schematic

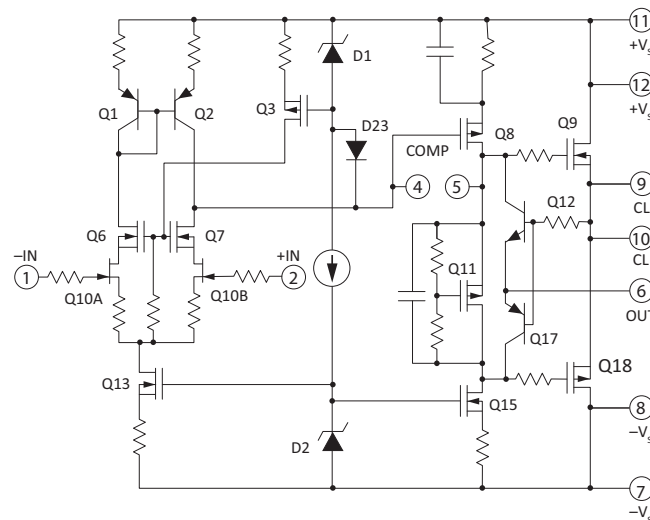

TYPICAL CONNECTIONS

Figure 2: Typical Connections

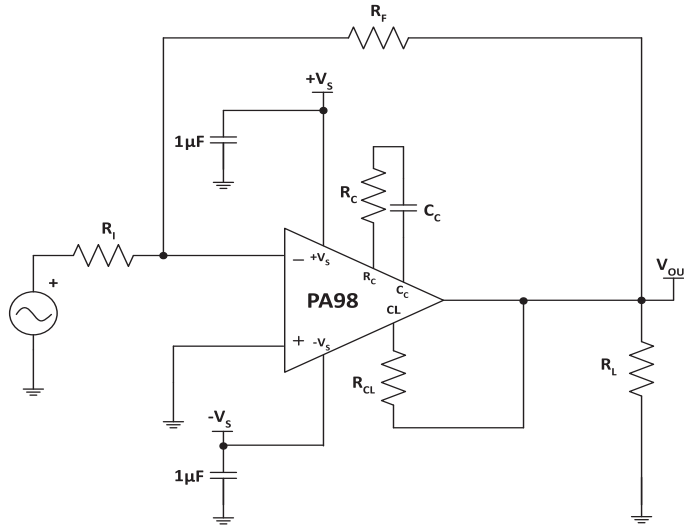

PINOUT AND DESCRIPTION TABLE

Figure 3: External Connections

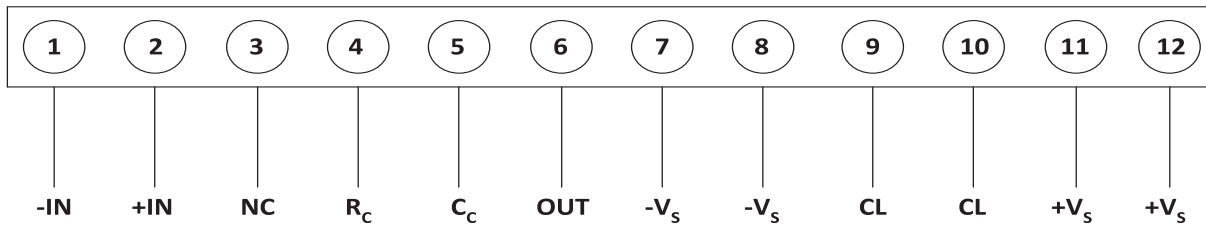

Pin Number	Name	Description
1	-IN	Inverting input.
2	+IN	Non-inverting input.
3	NC	This is a no connect, leave this pin floating.
4	R _C	Compensation Resistor connection, select value based on Phase Compensation. See applicable section.
5	C _C	Compensation Capacitive connection, select value based on Phase Compensation. See applicable section.
6	OUT	Connect pin to load and feedback resistors.
7, 8	-V _S	The negative supply rail. Pins 7 and 8 are internally connected.
9, 10	CL	Connect to the current limit resistor, and then the OUT pin. Output current flows into/out of these pins through R _{CL} . Pins 9 and 10 are internally connected.
11, 12	+V _S	The positive supply rail. Pins 11 and 12 are internally connected.

SPECIFICATIONS

Unless otherwise noted: $T_C = 25^\circ\text{C}$, compensation: $C_C = 68\text{pF}$, $R_C = 100\ \Omega$. DC input specifications are \pm value given. Power supply voltage is typical rating.

ABSOLUTE MAXIMUM RATINGS

Parameter	Symbol	Min	Max	Unit
Supply Voltage, total	$+V_S$ To $-V_S$		450	V
Output Current, Continuous Within SOA	I_{OUT}		200	mA
Power Dissipation, Continuous @ $T_C = 25^\circ\text{C}$ ¹	P_D		30	W
Input Voltage, Differential	$V_{\text{IN (diff)}}$	-25	+25	V
Input Voltage, Common Mode	V_{CM}	$-V_S$	$+V_S$	V
Temperature, Pin Solder, 10s Max.			260	$^\circ\text{C}$
Temperature, Junction ¹	T_J		150	$^\circ\text{C}$
Temperature Range, Storage		-55	+125	$^\circ\text{C}$
Operating Temperature Range, Case	T_C	-40	+85	$^\circ\text{C}$

1. Long term operation at the maximum junction temperature will result in reduced product life. Derate internal power dissipation to achieve high MTTF. Ratings apply only to output transistors. An additional 10W may be dissipated due to quiescent power.

CAUTION

The PA98 is constructed from MOSFET transistors. ESD handling procedures must be observed. The substrate contains beryllia (BeO). Do not crush, machine, or subject to temperatures in excess of $850\ ^\circ\text{C}$ to avoid generating toxic fumes.

INPUT

Parameter	Test Conditions	PA98			PA98A			Units
		Min	Typ	Max	Min	Typ	Max	
Offset Voltage, Initial			0.5	2		0.25	0.5	mV
Offset Voltage vs. Temp	Full temp range		10	30		5	10	$\mu\text{V}/^\circ\text{C}$
Offset Voltage vs. Supply			3	10		*	*	$\mu\text{V}/\text{V}$
Offset Voltage vs. Time			75			*		$\mu\text{V}/\text{hr}$
Bias Current, Initial ¹			5	50		3	10	pA
Bias Current, vs. Supply			0.01			*		pA/V
Offset Current, Initial ¹			10	100		3	30	pA
Input Impedance, Dc			10^{11}			*		Ω
Input Capacitance			4			*		pF
Common Mode Voltage Range ²		$\pm V_S - 15$			*			V
Common Mode Rejection, Dc	$V_{\text{CM}} = \pm 90\text{V}$	90	110		*	*		dB
Noise	100 kHz BW, $R_S = 1\text{ k}\Omega$, $C_C = 10\text{pf}$		1			*		$\mu\text{V RMS}$

1. Doubles for every 10°C of temperature increase.
2. $+V_S$ and $-V_S$ denote the positive and negative power supply rail respectively.

GAIN

Parameter	Test Conditions	PA98			PA98A			Units
		Min	Typ	Max	Min	Typ	Max	
Open Loop Gain @ 15 Hz	$R_L = 2\text{ k}\Omega$, $C_C = \text{Open}$	96	111		*	*		dB
Gain Bandwidth Product @ 1 MHz	$R_L = 2\text{ k}\Omega$, $C_C = 3.3\text{pf}$		100			*		MHz
Power Bandwidth	$C_C = 10\text{pf}$		300			*		kHz
	$C_C = 3.3\text{pf}$		500			*		kHz
Phase Margin	Full temp range		60			*		°

OUTPUT

Parameter	Test Conditions	PA98			PA98A			Units
		Min	Typ	Max	Min	Typ	Max	
Voltage Swing ¹	$I_{\text{OUT}} = \pm 200\text{mA}$	$\pm V_S - 10$	$\pm V_S - 6.5$		*	*		V
Voltage Swing ¹	$I_{\text{OUT}} = \pm 75\text{mA}$	$\pm V_S - 8.5$	$\pm V_S - 6.0$		*	*		V

Voltage Swing ¹	$I_{OUT} = \pm 20\text{mA}$	$\pm V_S - 8.0$	$\pm V_S - 5.5$		*	*		V
Current, Continuous	$T_C = 85^\circ\text{C}$	± 200				*		mA
Slew Rate, $A_V = 20$	$C_C = 10\text{pF}$		400			*		V/ μs
Slew Rate, $A_V = 100$	$C_C = \text{Open}$		1000		700	*		V/ μs
Capacitive Load, $A_V = +1$	Full temp range	470			*			pF
Settling Time To 0.1%	$C_C = 10\text{pF}$, 2V step		1			*		μs
Resistance, No Load	$R_{CL} = 0$		50			*		Ω

1. $+V_S$ and $-V_S$ denote the positive and negative power supply rail respectively.

POWER SUPPLY

Parameter	Test Conditions	PA98			PA98A			Units
		Min	Typ	Max	Min	Typ	Max	
Voltage ¹	Full temp range	± 15	± 150	± 225	*	*	*	V
Current, Quiescent			21	25		*	*	mA

1. Derate max supply rating 0.625 V/ $^\circ\text{C}$ below 25 $^\circ\text{C}$ case temperature. No derating needed above 25 $^\circ\text{C}$ case.

THERMAL

Parameter	Test Conditions	PA98			PA98A			Units
		Min	Typ	Max	Min	Typ	Max	
Resistance, Ac, Junction To Case ¹	Full temp range, $F > 60\text{ Hz}$			2.5			*	$^\circ\text{C}/\text{W}$
Resistance, Dc, Junction To Case	Full temp range, $F < 60\text{ Hz}$			4.2			*	$^\circ\text{C}/\text{W}$
Resistance, Junction To Air	Full temp range		30			*		$^\circ\text{C}/\text{W}$
Temperature Range, Case	Meets full range specifications	-25		+85	*		*	$^\circ\text{C}$

1. Rating applies if the output current alternates between both output transistors at a rate faster than 60 Hz.

Note: * The specification of PA98A is identical to the specification for PA98 in applicable column to the left.

TYPICAL PERFORMANCE GRAPHS

Figure 4: Power Derating

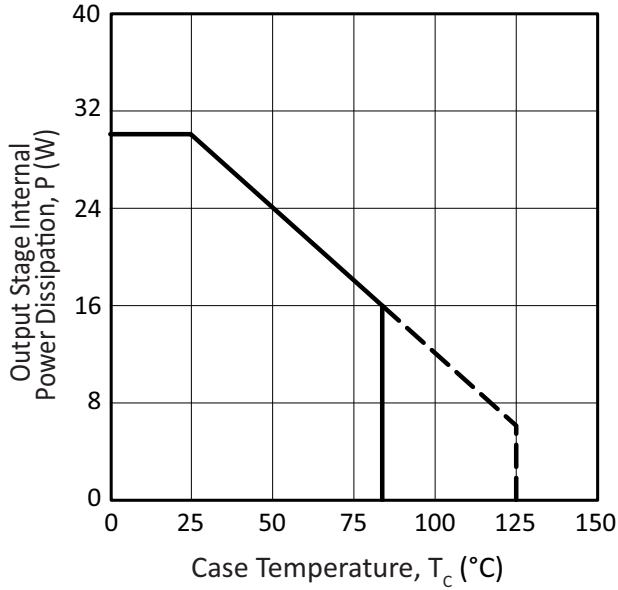

Figure 5: Quiescent Current

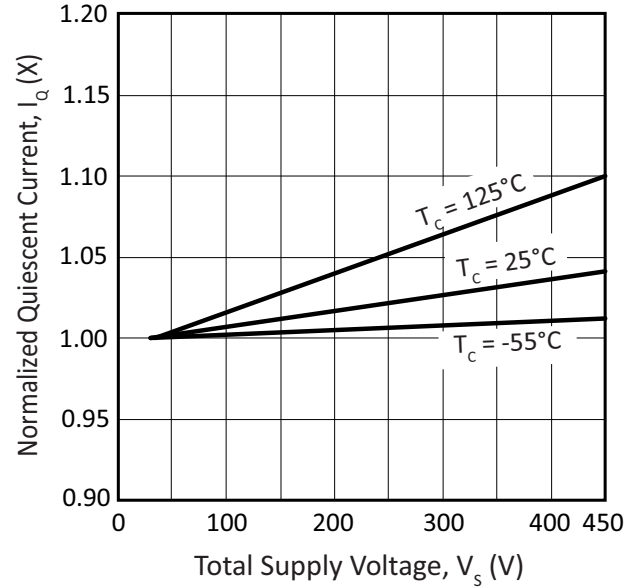

Figure 6: Small Signal Response

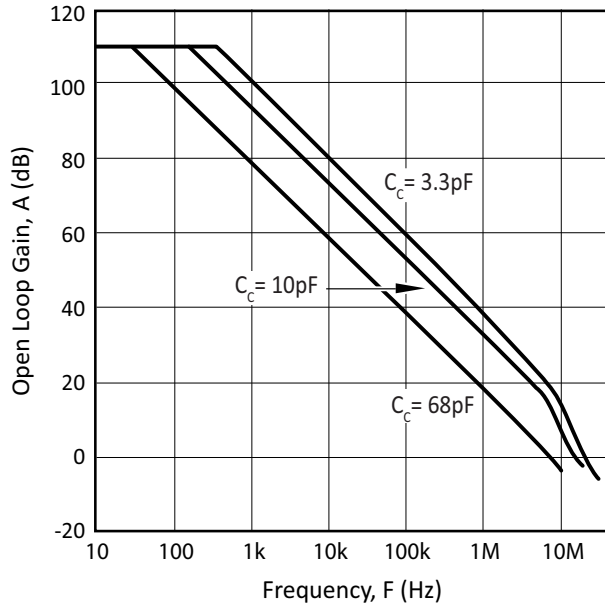

Figure 7: Phase Response

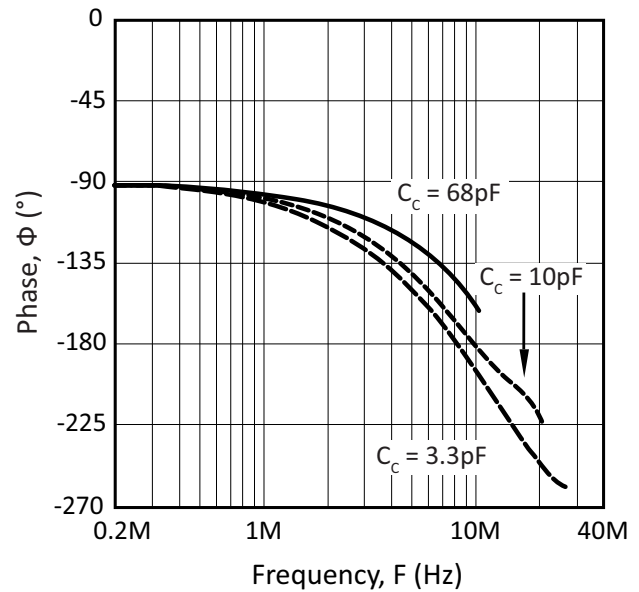

Figure 8: Output Voltage Swing

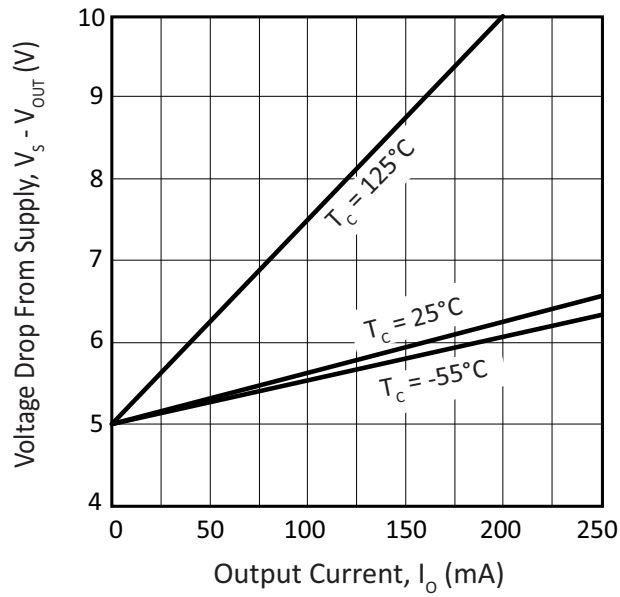

Figure 9: Power Response

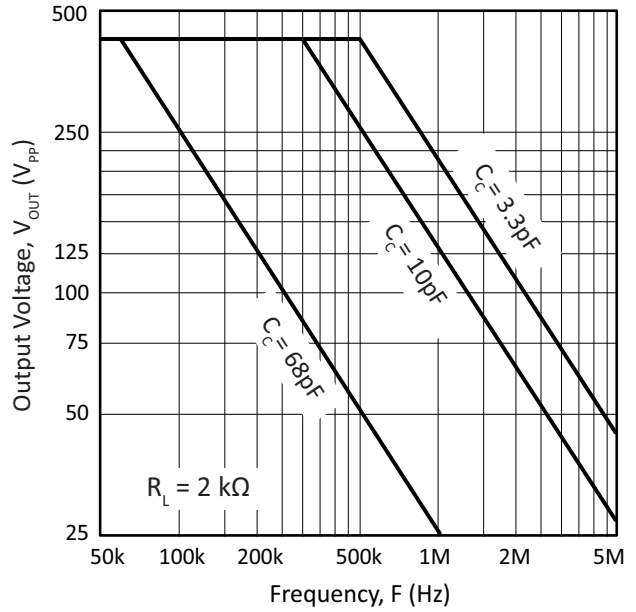

Figure 10: Slew Rate

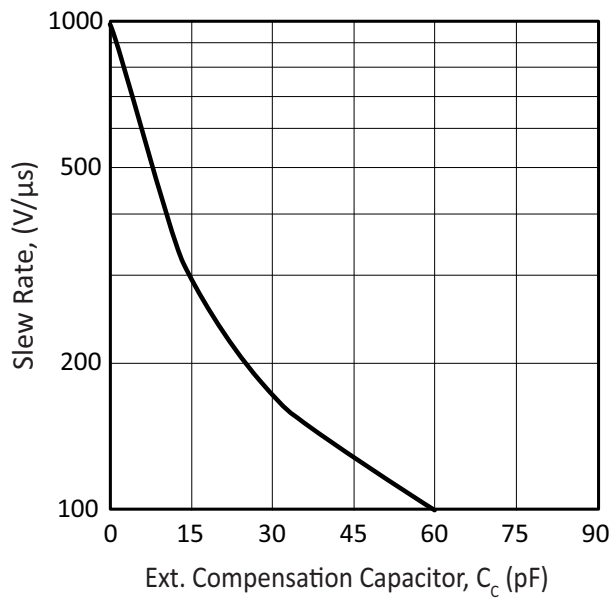

Figure 11: Harmonic Distortion

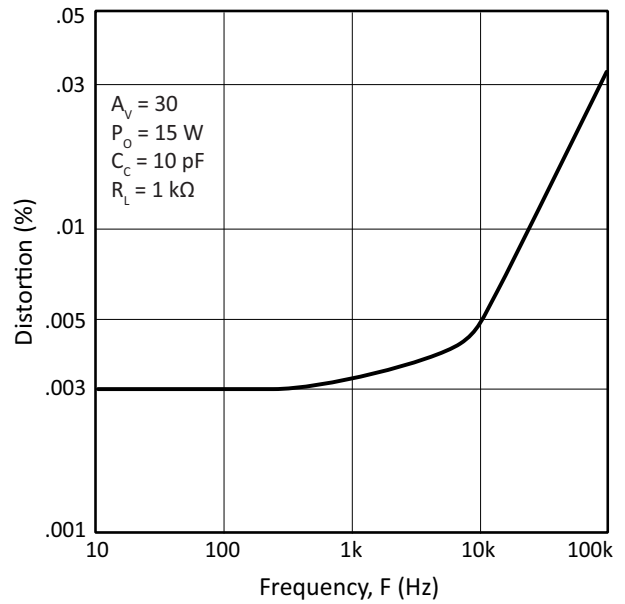

Figure 12: Input Noise Voltage

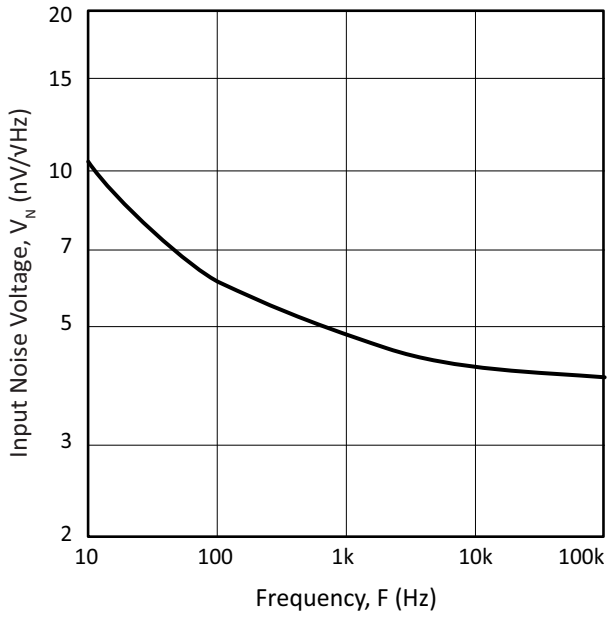

Figure 13: Common Mode Rejection

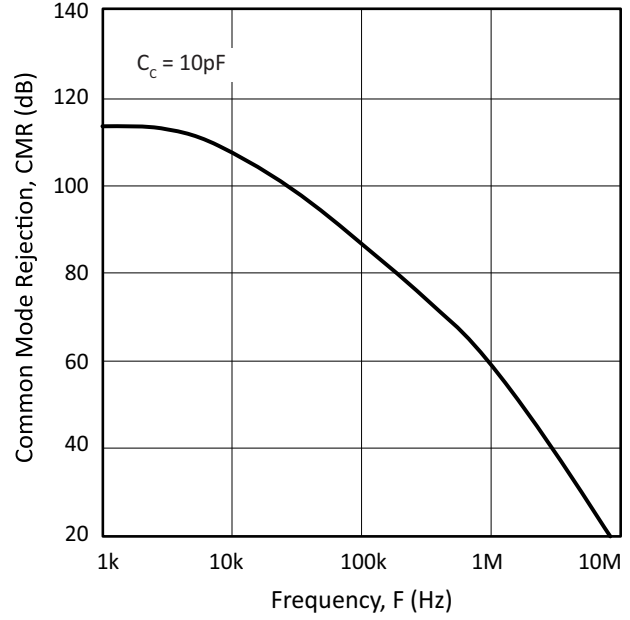

Figure 14: Power Supply Rejection

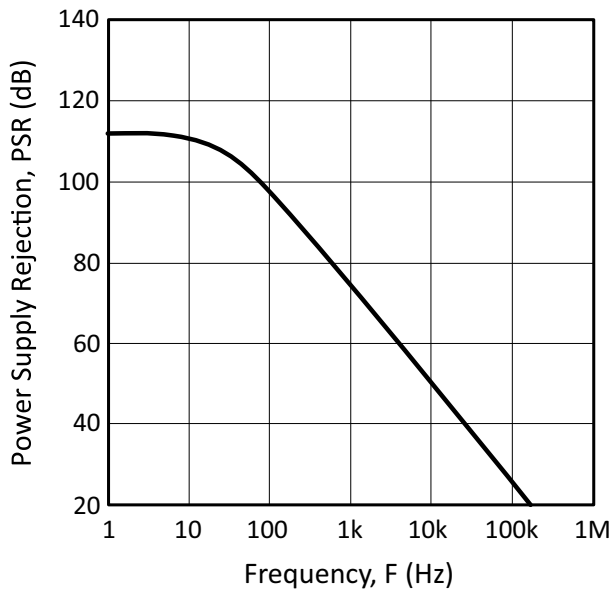
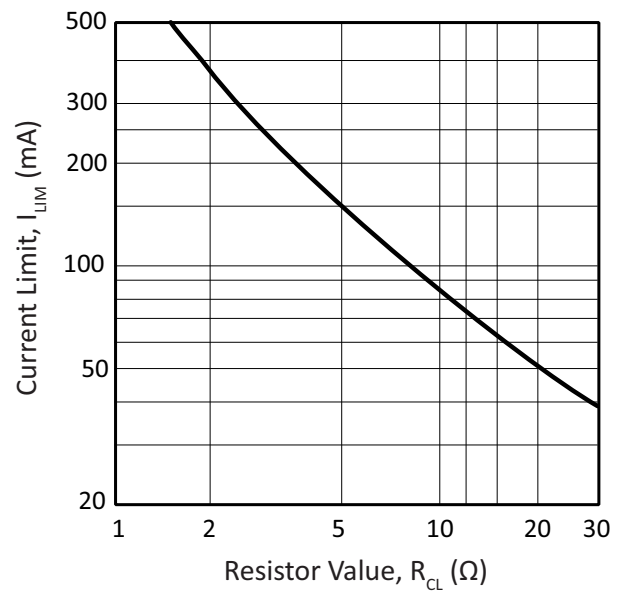

Figure 15: Current Limit



SAFE OPERATING AREA (SOA)

The safe operating area curves define the maximum additional internal power dissipation the amplifier can tolerate when it produces the necessary output to drive an external load. This is not the same as the absolute maximum internal power dissipation listed elsewhere in the specification since the quiescent power dissipation is significant compared to the total.

The MOSFET output stage of this power operational amplifier has two distinct limitations:

1. The current handling capability of the MOSFET geometry and the wire bonds.
2. The junction temperature of the output MOSFETs.

Note: The output stage is protected against transient flyback. However, for protection against sustained, high energy flyback, external fast-recovery diodes should be used.

Figure 16: SOA

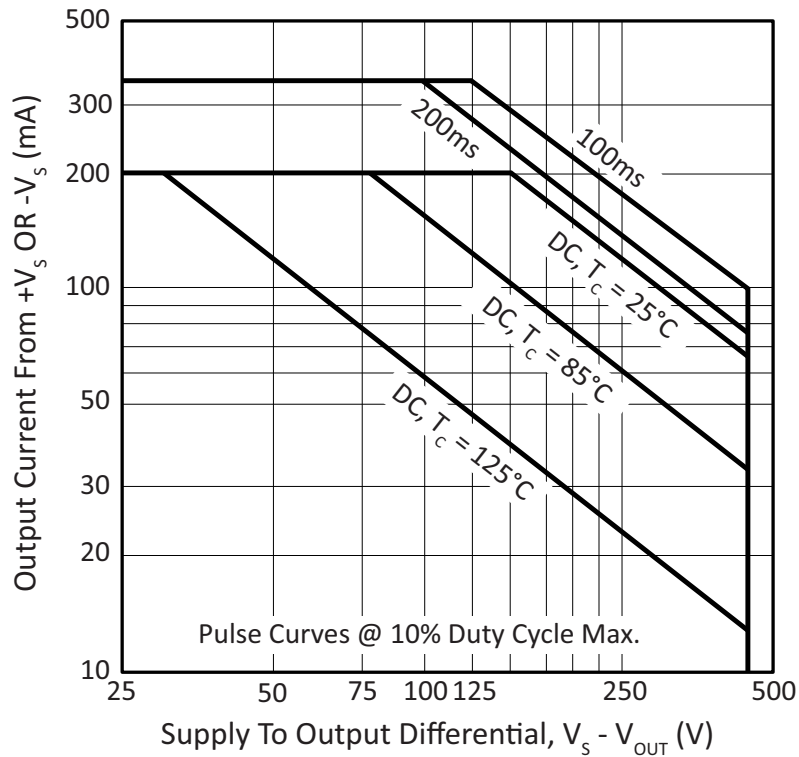

GENERAL

Please read Application Note 1 “General Operating Considerations” which covers stability, supplies, heat sinking, mounting, current limit, SOA interpretation, and specification interpretation. Visit www.apexanalog.com for Apex Microtechnology’s complete Application Notes library, Technical Seminar Workbook, and Evaluation Kits.

TYPICAL APPLICATION

DYNAMIC FOCUSING

The advancement of medical and industrial technology has driven the need to dynamically focus a beam with better resolution, decrease scan repetition and increase the scan distance. High speed dynamic focus control is used in metrology, spectroscopy, and tomography. Continuous advancements in measurement and correction techniques, continually drive the need for higher bandwidth. The PA98 is a high voltage, high speed amplifier that is well suited for this application. Configure the device as a summing amplifier by connecting the negative input to the nominal focus potential and its dynamic correction. The nominal can either be derived from a digital potentiometer, or perhaps automatic focusing circuitry. The dynamic correction is generated from the sweep voltages, by calculating the distance of the beam from the target. These targets can include, but are not limited to: blood, tissue, gas, fluid, the sea floor, and the integrity of laser welds.

Figure 17: Typical Application

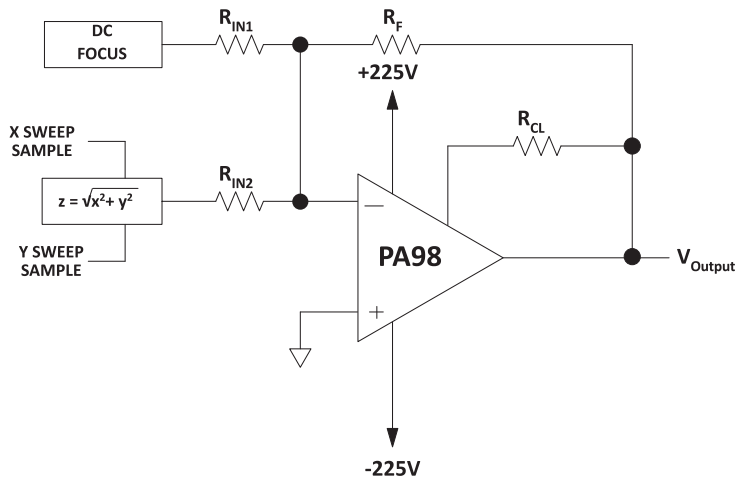

PHASE COMPENSATION

Gain	C _C	R _C
1	68pF	100 Ω
20	10pF	330 Ω
100	3.3pF	0 Ω

C_C Rated For Full Supply Voltage

STABILITY

The PA98 is externally compensated and performance can be tailored to the application. Use the graphs of small signal response and power response as a guide. The compensation capacitor C_C must be rated at 500V working voltage. An NPO capacitor is recommended. The compensation network $C_C R_C$ must be mounted closely to the amplifier pins 7 and 8 to avoid spurious oscillation.

CURRENT LIMIT

For proper operation, the current limit resistor (R_{CL}) must be connected as shown in the external connection diagram. The minimum value is 1.4Ω , however for optimum reliability the resistor value should be set as high as possible. The value is calculated as follows; with the maximum practical value of 30Ω .

$$R_{CL}(\Omega) = \frac{0.7V}{I_{CL(A)} - 0.016}$$

INPUT PROTECTION

Although the PA98 can withstand differential voltages up to $\pm 25V$, additional external protection is recommended. Since the PA98 is a high speed amplifier, low leakage, low capacitance JFETs connected as diodes are recommended (e.g. 2N4416, Q1-Q4 in Figure 18). The differential input voltage will be clamped to $\pm 1.4V$. This is sufficient overdrive to produce maximum power bandwidth.

POWER SUPPLY PROTECTION

Unidirectional transient voltage suppressors diodes are recommended as protection on the supply pins. The diodes clamp transients to voltages within the power supply rating and also clamp power supply reversals to ground. Whether the diodes are used or not, the system power supply should be evaluated for transient performance including power-on overshoot and power-off polarity reversals as well as line regulation. Conditions which can cause open circuits or polarity reversals on either power supply rail should be avoided or protected against. Reversals or opens on the negative supply rail are known to induce input stage failure. Unidirectional TVS diodes prevent this, and it is desirable that they be both electrically and physically as close to the amplifier as possible.

Figure 18: Over Voltage Protection

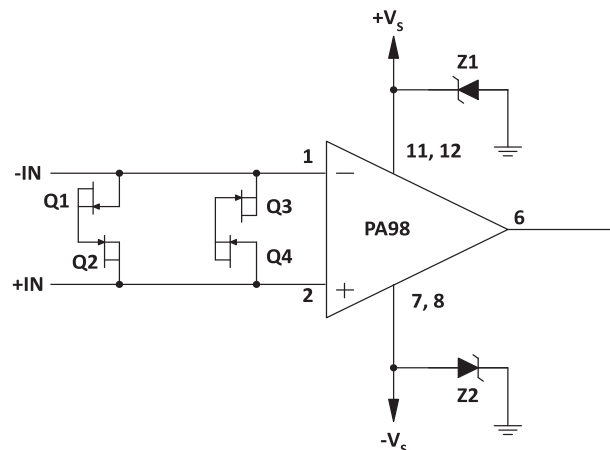

INTERNAL POWER DISSIPATION AND HEATSINK SELECTION

With the unique combination of high voltage and speed of the PA98, traditional formulas for heatsink selection will falsely lower the apparent power handling capability of this amplifier. To predict operating temperatures use the following procedure:

Find internal dissipation (PD) resulting from driving the load. Refer to Apex Microtechnology Applications Note 1, General Operating Considerations, paragraph 7. Find total quiescent power (PD_Q) by multiplying 0.025A by V_{SS} (total supply voltage). Find output stage quiescent power (PD_{QOUT}) by multiplying 0.001 by V_{SS}. Calculate a heatsink rating which will maintain the case at 85°C or lower.

$$R_{\theta SA} = \frac{T_C - T_A}{PD + PD_Q} - 0.1 \left(\frac{^\circ C}{W} \right)$$

Where: T_C = maximum case temperature allowed

T_A = maximum ambient temperature encountered

Calculate a heatsink rating which will maintain output transistor junctions at 150°C or lower.

$$R_{\theta SA} = \frac{T_J - T_A - (PD + PD_{QOUT}) \cdot R_{\theta JC}}{PD + PD_Q} - 0.1 \left(\frac{^\circ C}{W} \right)$$

Where: T_J = maximum junction temperature allowed.

R_{θJC} = AC or DC thermal resistance from the specification table.

Use the larger heatsink of these two calculations.

PACKAGE OPTIONS

Part Number	Apex Package Style	Description
PA98	DP	12-Pin SIP
PA98A	DP	12-Pin SIP
PA98EE	EE	12-Pin SIP w/ formed leads

PACKAGE STYLE DP

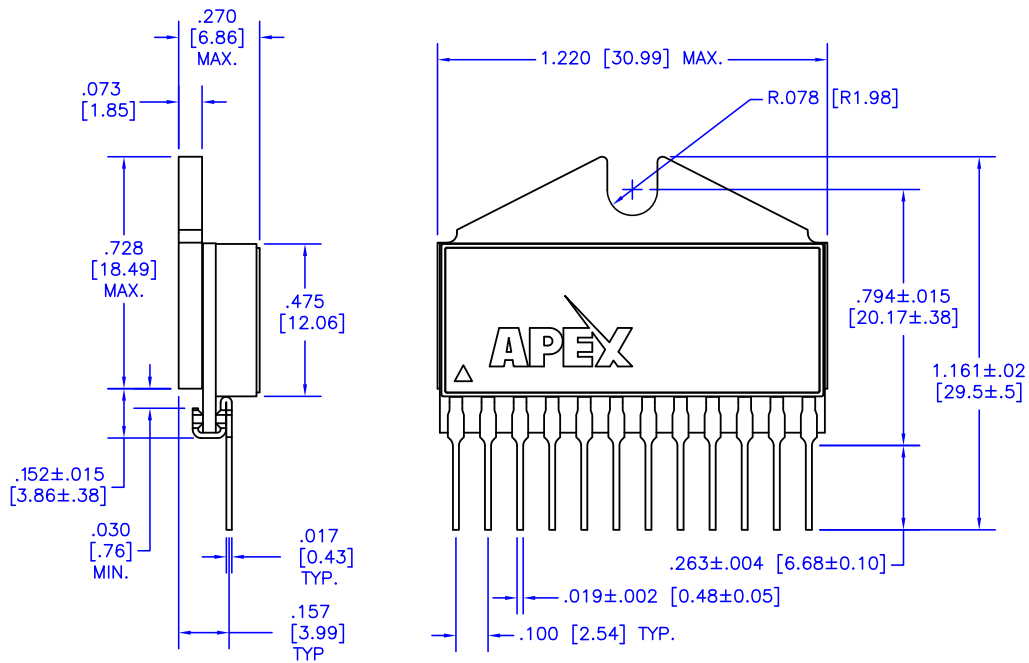
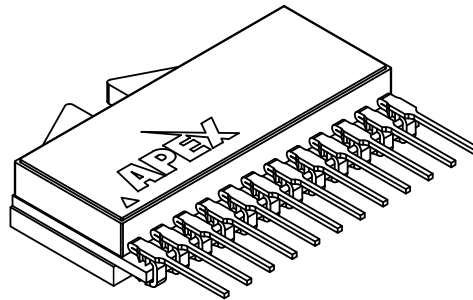

NOTES:

1. Dimensions are inches & [mm].
2. Triangle on lid denotes pin 1.
3. Pins: Alloy 510 phosphor bronze plated with matte tin (150 – 300 μ) over nickel (50 μ max.) underplate.
4. Package: Vectra liquid crystal polymer, black
5. Epoxy-sealed & ultrasonically welded non-hermetic package.
6. Package weight: .367 oz. [11.41 g]