

Dual Power Booster Amplifier

RoHS
COMPLIANT

FEATURES

- Wide Supply Range – ± 20 V to ± 75 V
- High Output Current – Up to 2 A Continuous
- Programmable Gain
- High Slew Rate – 800 V/ μ s Typical
- Programmable Output Current Limit
- High Power Bandwidth – 1 MHz
- Low Quiescent Current – 20 mA Typical (Total, Both Channels)

APPLICATIONS

- LED Test Equipment
- LCD Test Equipment
- Semiconductor Test Equipment
- High Voltage Instrumentation
- Electrostatic Transducers and Deflection
- Piezoelectric Positioning and Actuation
- Programmable Power Supplies

DESCRIPTION

The PB64 is a dual high voltage, high current booster amplifier designed to provide voltage and current gain for a small signal, general purpose op amp. Including the power booster within the feedback loop of the driver amplifier results in a composite amplifier with the accuracy of the driver and the extended output current capability of the booster.

The output stage utilizes complementary MOSFETs, providing symmetrical output impedance and eliminating second breakdown limitations imposed by Bipolar Junction Transistors. Although the booster can be configured quite simply, enormous flexibility is provided through the choice of driver amplifier, current limit and supply voltage.

This hybrid circuit utilizes a Beryllia (BeO) substrate, thick film resistors, ceramic capacitors and semiconductor chips to maximize reliability, minimize size and give top performance. Ultrasonically bonded aluminum wires provide reliable interconnections at all operating temperatures. The PB64 is packaged in Apex Microtechnology's 12-pin power SIP. The case is electrically isolated.



TYPICAL CONNECTION

Figure 1: Typical Connection

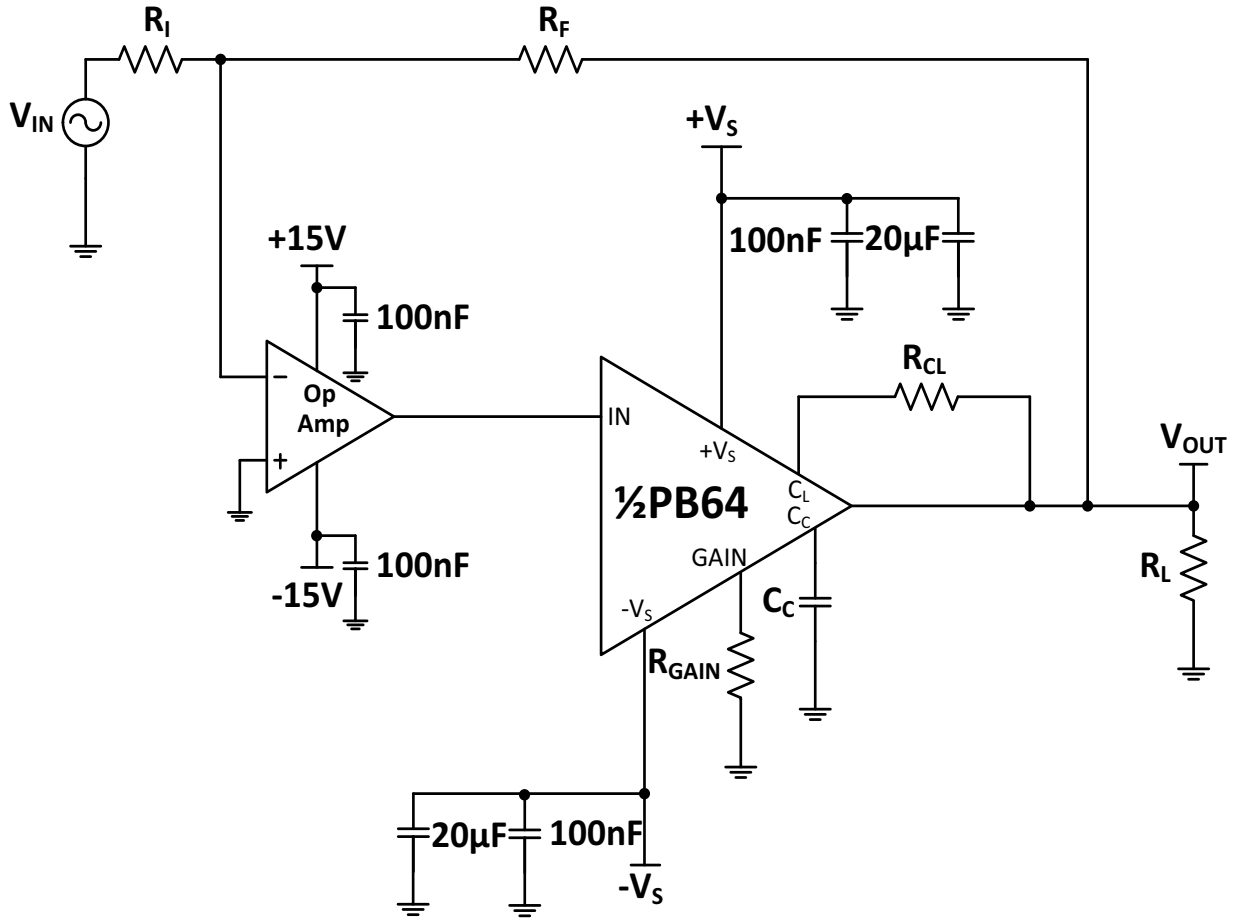

PINOUT AND DESCRIPTION TABLE

Figure 2: External Connections

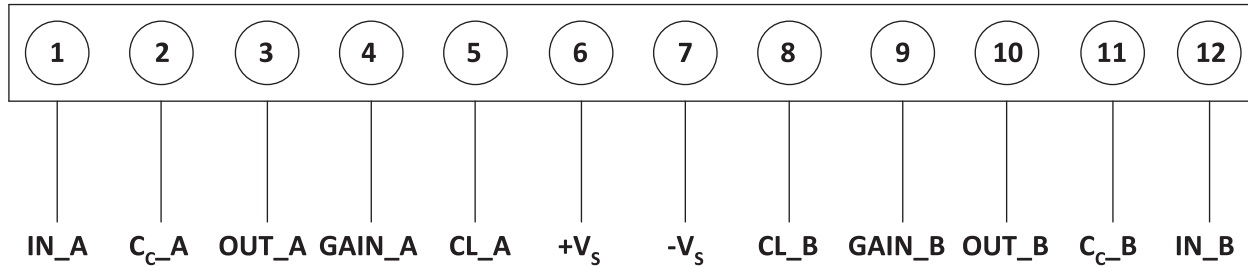

Pin Number	Name	Description
1	IN_A	The input for channel A.
2	CC_A	Compensation capacitor connection for channel A. Select value based on Phase Compensation. See applicable section.
3	OUT_A	The output for channel A. Connect this pin to load and to the feedback resistors.
4	GAIN_A	Gain resistor pin for channel A. Connect R _{GAIN_A} between GAIN_A and ground. This will specify the gain for the power booster itself, not the composite amplifier. See applicable section.
5	CL_A	Connect to the current limit resistor. Output current flows into/out of these pins through R _{CL} . The output pin and the load are connected to the other side of R _{CL} .
6	+Vs	The positive supply rail for both channels.
7	-Vs	The negative supply rail for both channels.
8	CL_B	Connect to the current limit resistor. Output current flows into/out of these pins through R _{CL} . The output pin and the load are connected to the other side of R _{CL} .
9	GAIN_B	Gain resistor pin for channel B. Connect R _{GAIN_B} between GAIN_B and ground. This will specify the gain for the power booster itself, not the composite amplifier. See applicable section.
10	OUT_B	The output for channel B. Connect this pin to load and to the feedback resistors.
11	CC_B	Compensation capacitor connection for channel B. Select value based on Phase Compensation. See applicable section.
12	IN_B	The input for channel B.

SPECIFICATIONS (PER AMPLIFIER)

All Min/Max characteristics and specifications are guaranteed over the Specified Operating Conditions. Typical performance characteristics and specifications are derived from measurements taken at typical supply voltages and $T_C = 25^\circ\text{C}$.

ABSOLUTE MAXIMUM RATINGS

Parameter	Symbol	Min	Max	Units
Supply Voltage, total	$+V_S$ to $-V_S$		200	V
Output Current, peak, per channel within SOA	I_O		2	A
Power Dissipation, internal DC ¹	P_D		90	W
Input Voltage, referred to common	V_{IN}	$(-V_S + 10V) / A_V$	$(+V_S - 10V) / A_V$	V
Temperature, pin solder, 10s max.			260	$^\circ\text{C}$
Temperature, junction ²	T_J		150	$^\circ\text{C}$
Temperature Range, storage		-55	+125	$^\circ\text{C}$
Operating Temperature Range, case	T_C	-25	+85	$^\circ\text{C}$

1. Each device in the package is capable of dissipating 45W internally.
2. Long term operation at the maximum junction temperature will result in reduced product life. Derate power dissipation to achieve high MTTF.

The PB64 is constructed from MOSFET devices. ESD handling procedures must be observed. **CAUTION** The substrate contains beryllia (BeO). Do not crush, machine or subject to temperatures in excess of 850°C to avoid generating toxic fumes.

INPUT

Parameter	Test Conditions	PB64			PB64A			Units
		Min	Typ	Max	Min	Typ	Max	
Offset Voltage, initial		-20	± 5	+20	-10	*	+10	mV
Offset Voltage vs. Temperature	Full temp range		+0.04			*		mV/ $^\circ\text{C}$
Input Bias Current	Full temp range	-50	± 4	+50	-25	*	+25	μA
Input Resistance, DC			97			*		M Ω
Input Capacitance			3			*		pF
Noise	f = 10 kHz		25			*		nV/ $\sqrt{\text{Hz}}$
DC Power Supply Rejection		87	100		*	*		dB
DC Common Mode Rejection		75	78		*	*		dB

GAIN (EACH CHANNEL)

Parameter	Test Conditions	PB64			PB64A			Units
		Min	Typ	Max	Min	Typ	Max	
Open Loop Gain	$f = 10 \text{ kHz}$		83			*		dB
Bandwidth, -3db	$A_V = 5V/V, R_L = 50 \Omega$		600			*		kHz
Power Bandwidth, $100V_{p-p}$	$A_V = 5V/V, R_L = 50 \Omega$		1			1		MHz

OUTPUT (EACH CHANNEL)

Parameter	Test Conditions	PB64			PB64A			Units
		Min	Typ	Max	Min	Typ	Max	
Voltage Swing	$I_O = 2A$	$ V_S - 11V$	$ V_S - 7.5V$		*	*		V
Voltage Swing	$I_O = 0.5A$		$ V_S - 6.5V$			*		V
Current, peak, source	Per Channel		2		2	*		A
Slew Rate	$R_L = 50 \Omega, 10V_{p-p}$ input step, $A_V = 10V/V$		800		600	800		V/ μ s
Capacitive Load, 25% Overshoot	$4V_{p-p}$ input step, $A_V = 5V/V$, Comp = 10pF		470			*		pF
Settling Time to 0.1%	$R_L = 50 \Omega, 4V_{p-p}$ input step, $A_V = 5V/V$		300			*		ns

POWER SUPPLY

Parameter ¹	Test Conditions	PB64			PB64A			Units
		Min	Typ	Max	Min	Typ	Max	
Voltage, $\pm V_S$		± 20	± 65	± 75	*	*	*	V
Current, quiescent	Both Channels		20	24		*	*	mA

1. $+V_S$ and $-V_S$ denote the positive and negative supply voltages.

PB64 • PB64A



MATCHING SPECIFICATIONS, VS=±75V, TC =25°C UNLESS OTHERWISE NOTED.

Parameter	Test Conditions	PB64			PB64A			Units
		Min	Typ	Max	Min	Typ	Max	
Input Offset Voltage Match			5			3	15	mV
Gain Match			0.2			*		%

THERMAL

Parameter	Test Conditions	PB64			PB64A			Units
		Min	Typ	Max	Min	Typ	Max	
Resistance, AC junction to case ¹	Full temp range, f ≥ 60 Hz		1.3	1.5		*	*	°C/W
Resistance, DC junction to case	Full temp range, f < 60 Hz		2.4	2.7		*	*	°C/W
Resistance, junction to air	Full temp range		30			*		°C/W
Operating Temperature Range, case		-25	25	85	*	*	*	°C

1. Rating applies if the output current alternates between both output transistors at a rate faster than 60 Hz.

TYPICAL PERFORMANCE GRAPHS

Figure 3: Power Derating

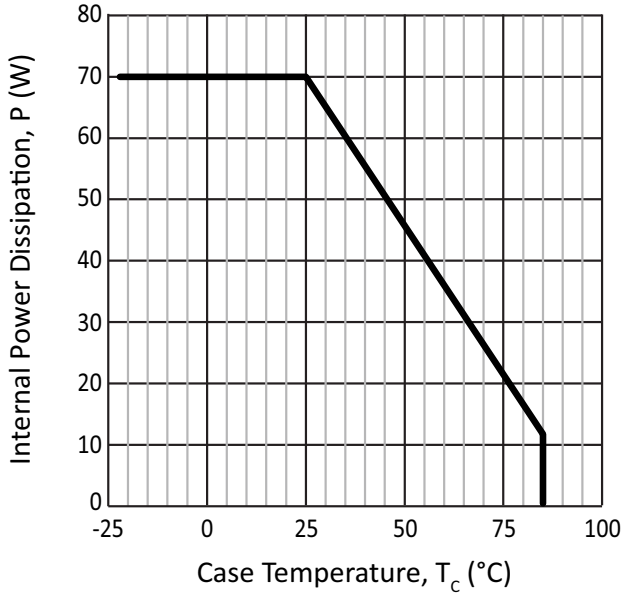

Figure 4: Pulse Response

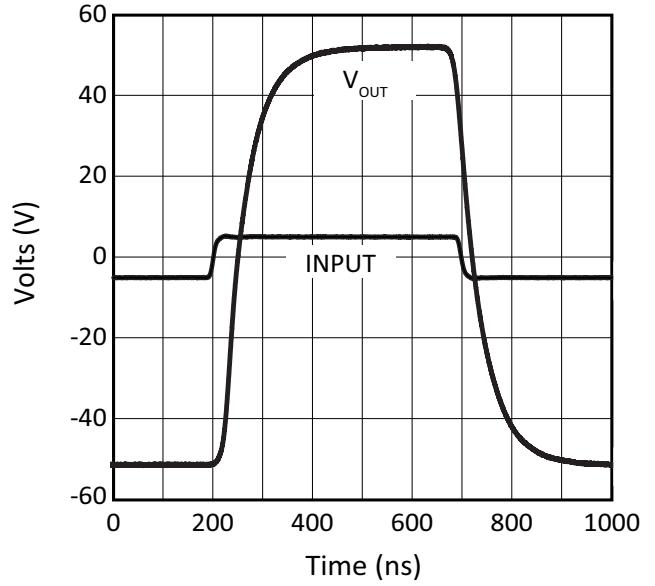

Figure 5: Output Voltage Swing

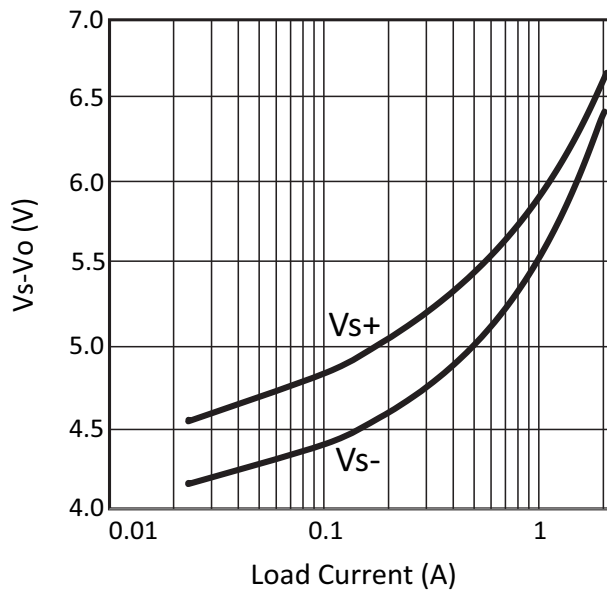

Figure 6: THD vs. Frequency

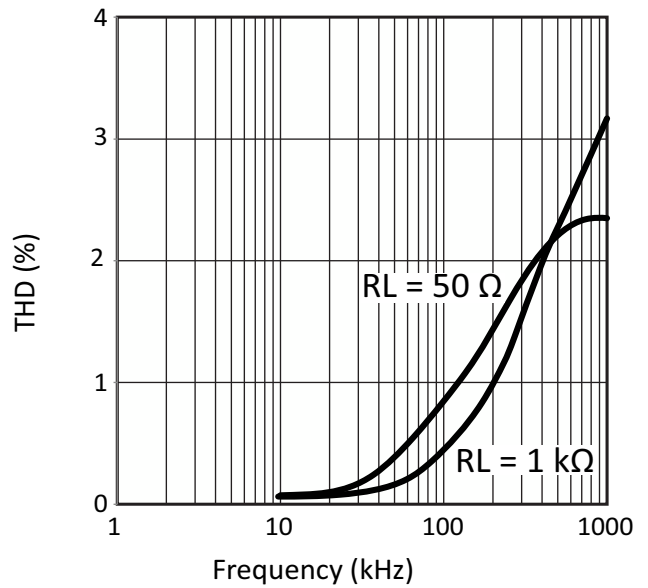

Figure 7: Small Signal Closed Loop Gain

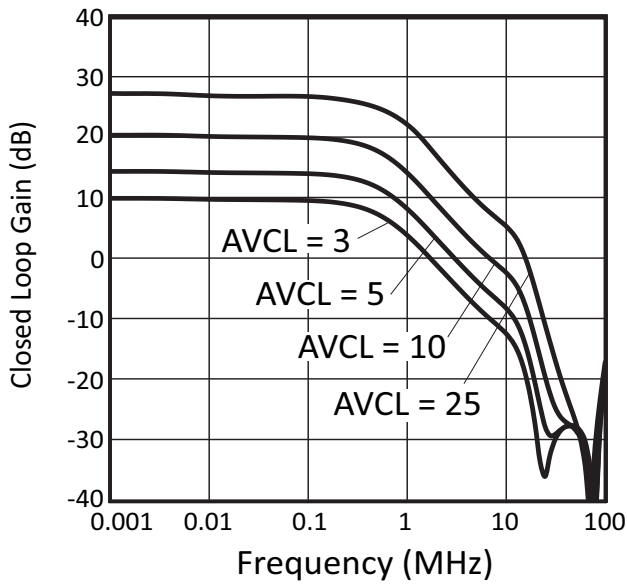

Figure 8: Small Signal Closed Loop Phase

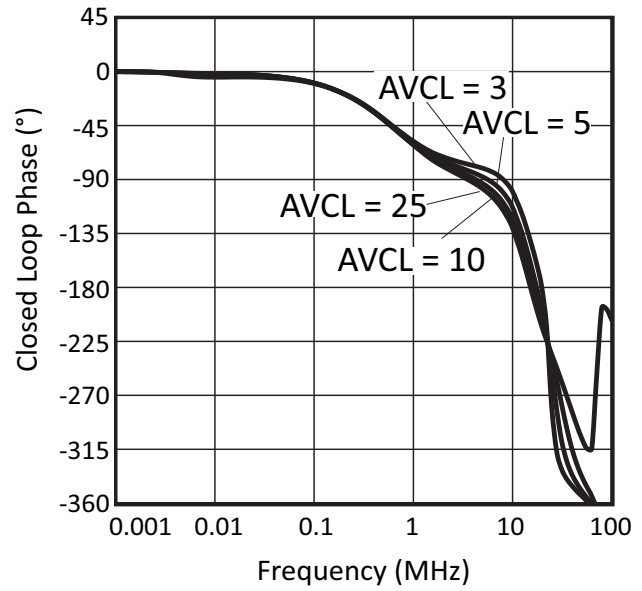

Figure 9: Quiescent Current

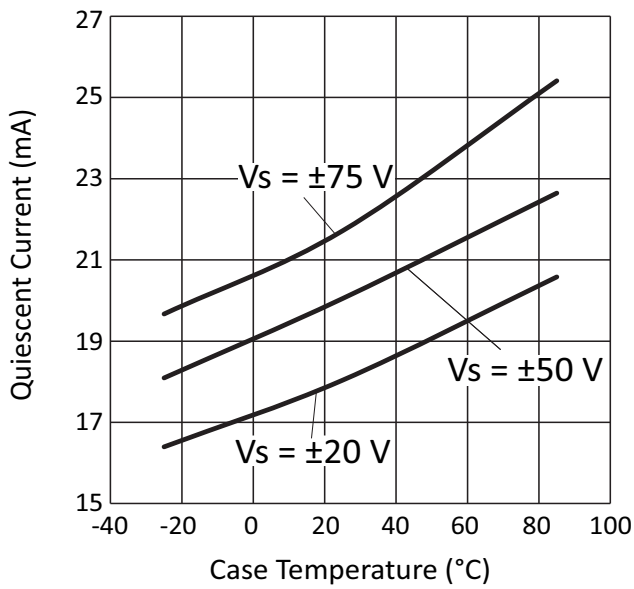

Figure 10: Current Limit vs. Temperature

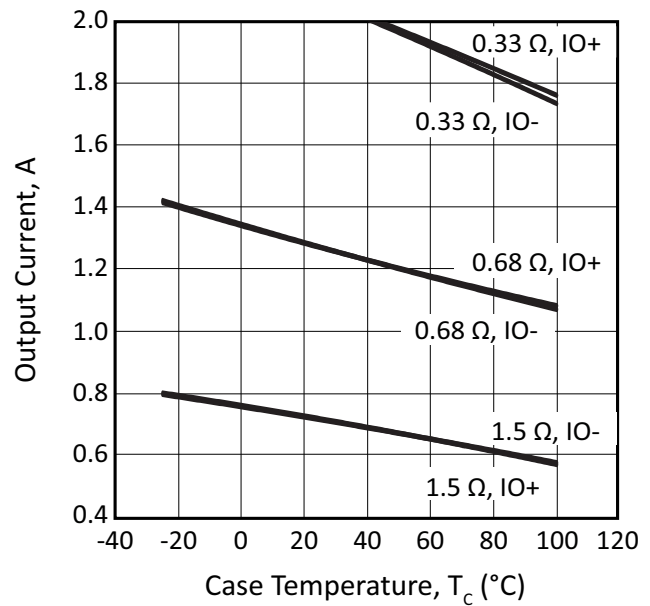

Figure 11: Rise and Fall Time vs. Temperature

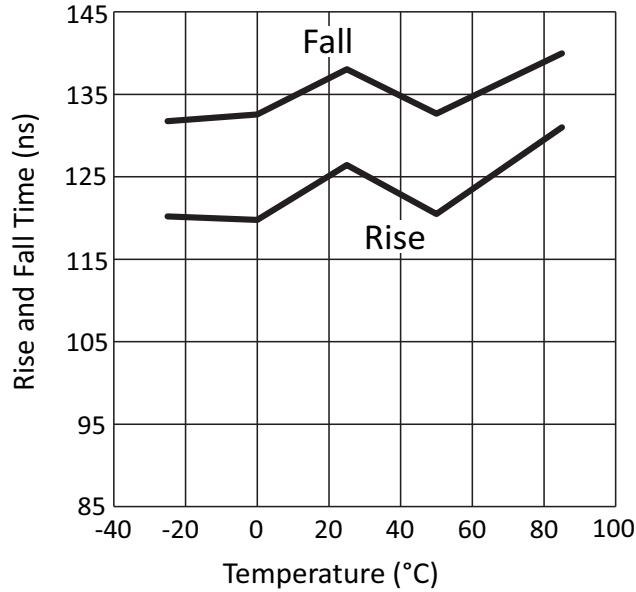

Figure 12: Power Supply Rejection Ratio

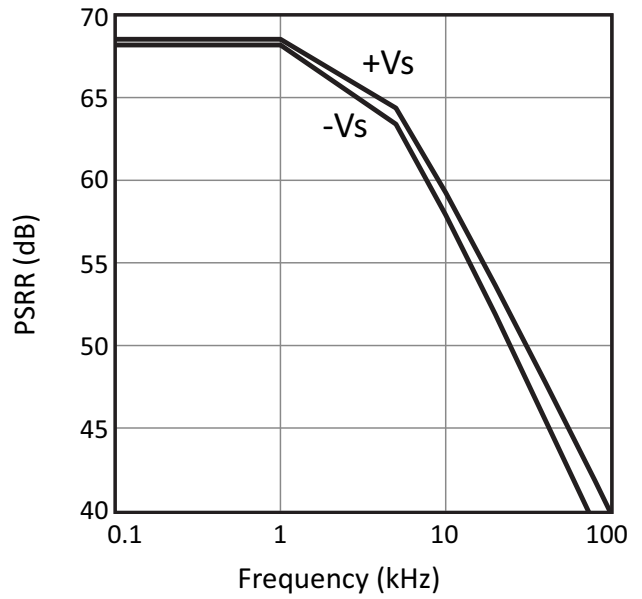

Figure 13: V_{OS} vs. Temperature

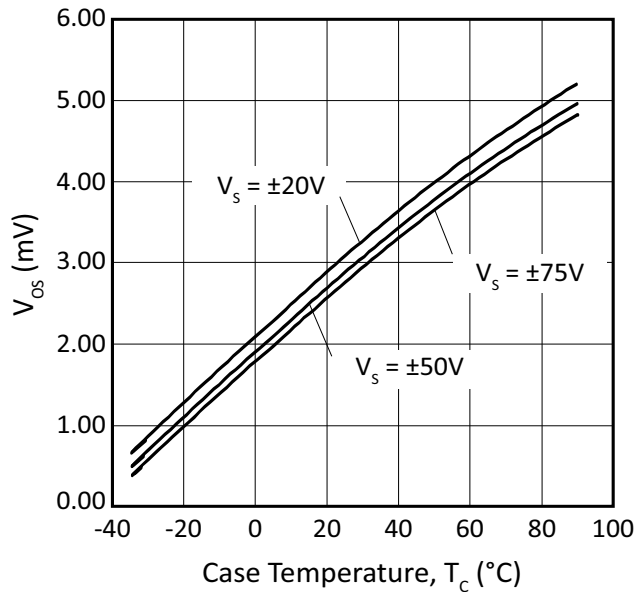
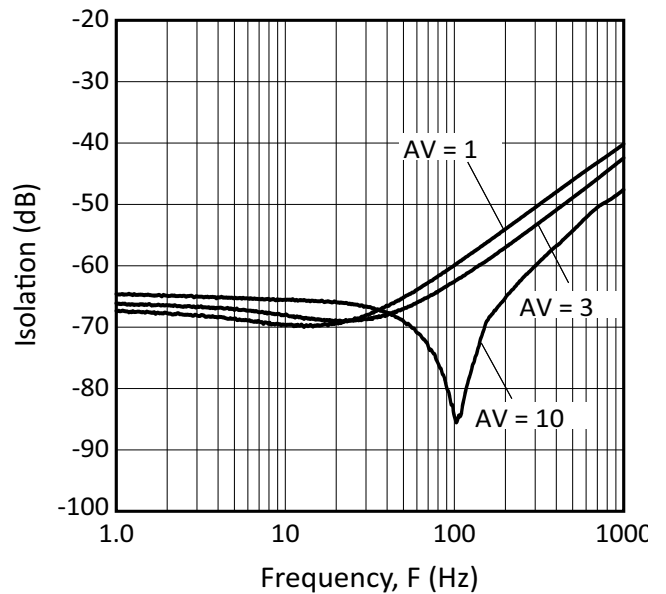

Figure 14: Channel Separation



SAFE OPERATING AREA (SOA)

The MOSFET output stage of the PB64 is not limited by second breakdown considerations as in bipolar output stages. Only thermal considerations and current handling capabilities limit the SOA (see Safe Operating Area graph). The output stage is protected against transient flyback by the parasitic body diodes of the output stage MOSFET structure. However, for protection against sustained high energy flyback external fast-recovery diodes must be used.

Figure 15: SOA (Per Channel)

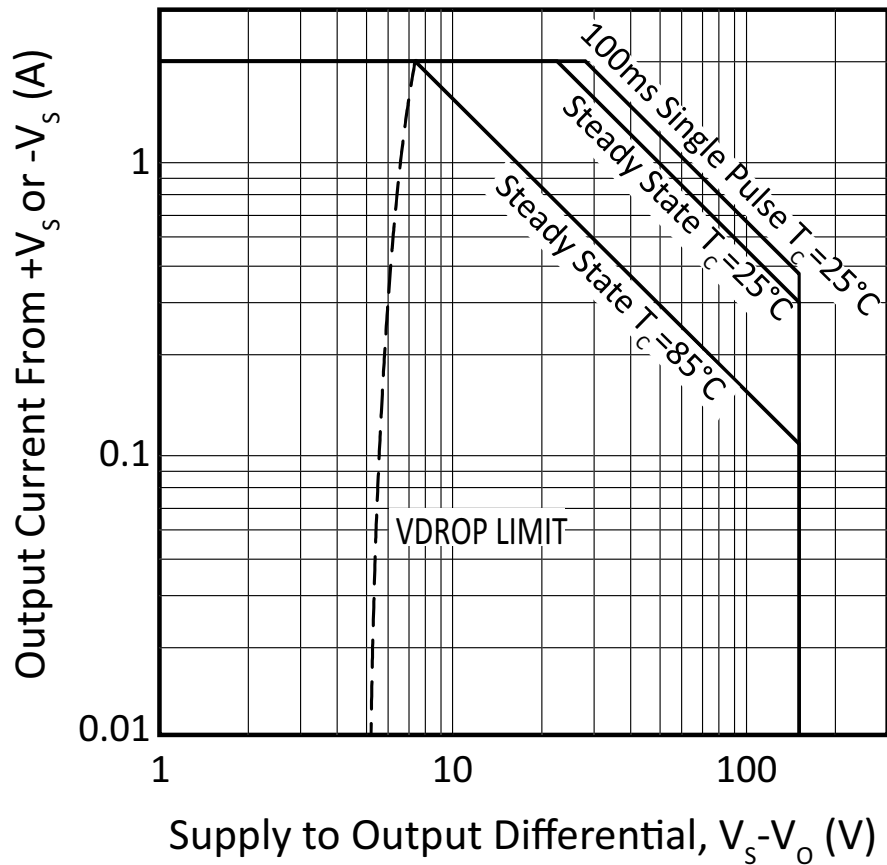

GENERAL

Please read Application Note 1 “General Operating Considerations” which covers stability, supplies, heat sinking, mounting, current limit, SOA interpretation, and specification interpretation. Visit www.apexanalog.com for Apex Microtechnology’s complete Application Notes library, Technical Seminar Workbook, and Evaluation Kits.

TYPICAL APPLICATION

Figure 16: Typical Application (Inverting Composite Amplifier)

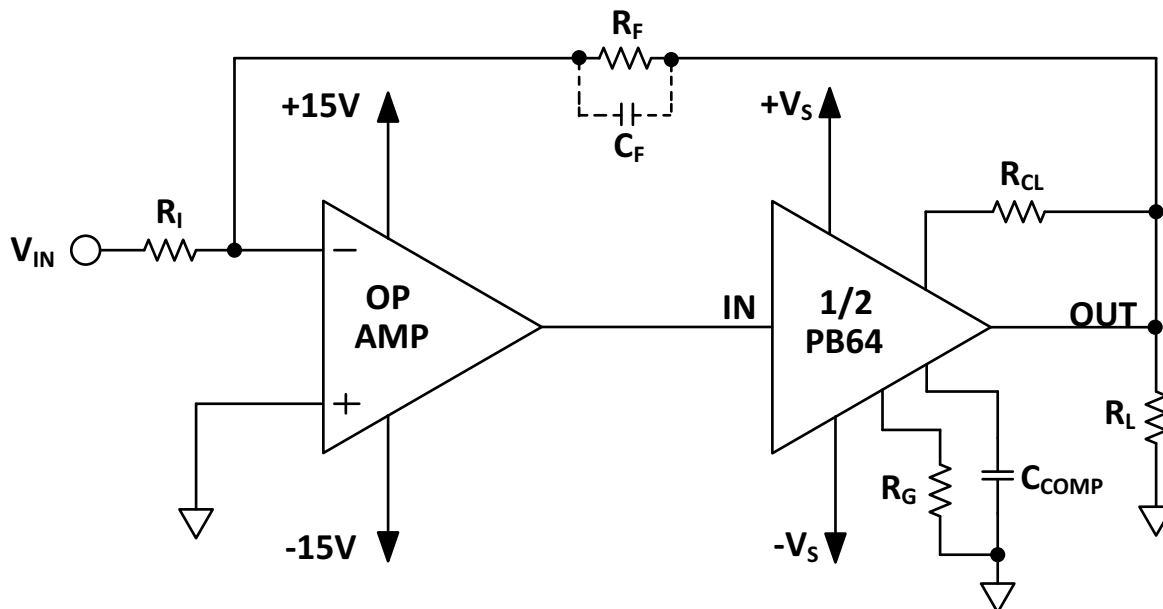

COMPOSITE AMPLIFIER CONSIDERATIONS

Cascading two amplifiers within a feedback loop has many advantages, but also requires careful consideration of several amplifier and system parameters. The most important of these are gain, stability, slew rate, and output swing of the driver.

STABILITY

Stability can be maximized by observing the following guidelines:

1. Keep gain-bandwidth product of the driver lower than the closed loop bandwidth of the booster. Use the lowest possible booster gain.
2. Minimize phase shift within the loop.

A good compromise is to set total (composite) gain at least a factor of 3 times booster gain. Phase shift within the loop is minimized through use of loop compensation capacitor C_F when required. Typical values are 5 pF to 33 pF. Stability is the most difficult to achieve in a configuration where driver effective gain is unity (i.e.; total gain = booster gain).

BOOSTER GAIN

The gain of each section may be set independently by selecting a value for the gain setting resistor R_G according to the relation:

$$GAIN = 1 + \frac{2000\Omega}{R_G}$$

where R_G is in ohms. Recommended gain range is $A_V = 3$ V/V to $A_V = 25$ V/V.

SLEW RATE

The slew rate of the composite amplifier is equal to the slew rate of the driver times the booster gain, with a maximum value equal to the booster slew rate.

OUTPUT SWING

The maximum output voltage swing required from the driver op amp is equal to the maximum output swing from the booster divided by the booster gain. The offset voltage of the booster over temperature must be taken into account. Note also that effects of booster gain accuracy should be considered when calculating maximum available driver swing.

POWER SUPPLY BYPASSING

Bypass capacitors to power supply terminals $+V_S$ and $-V_S$ must be connected physically close to the pins to prevent local parasitic oscillation in the output stage of the PB64. Use capacitors of at least 10 μ F for each supply. Bypass the large capacitors with high quality ceramic capacitors (X7R) of 0.1 μ F or greater.

CURRENT LIMIT

For proper operation, the current limit resistor (R_{LIM}) must be connected as shown in the typical connection diagram. For optimum reliability the resistor value should be set as high as possible. The value is calculated as follows; with the maximum practical value of 30 ohms. The current limit function can be disabled by shorting the CL pin to the OUT pin.

$$R_{LIM}(\Omega) = \frac{0.7V}{I_{LIM}(A)}$$

POWER SUPPLY PROTECTION

Unidirectional zener diode transient suppressors are recommended as protection on the supply pins. The zeners clamp transients to voltages within the power supply rating and also clamp power supply reversals to ground. Whether the zeners are used or not, the system power supply should be evaluated for transient performance including power-on overshoot and power-off polarity reversal as well as line regulation. Conditions which can cause open circuits or polarity reversals on either power supply rail should be avoided or protected against. Reversals or opens on the negative supply rail is known to induce input stage failure. Unidirectional transzorbors prevent this, and it is desirable that they be both electrically and physically as close to the amplifier as possible.

PACKAGE OPTIONS

Part Number	Apex Package Style	Description
PB64DP	DP	12-pin Power Sip
PB64DPA	DP	12-pin Power Sip

PACKAGE STYLE DP

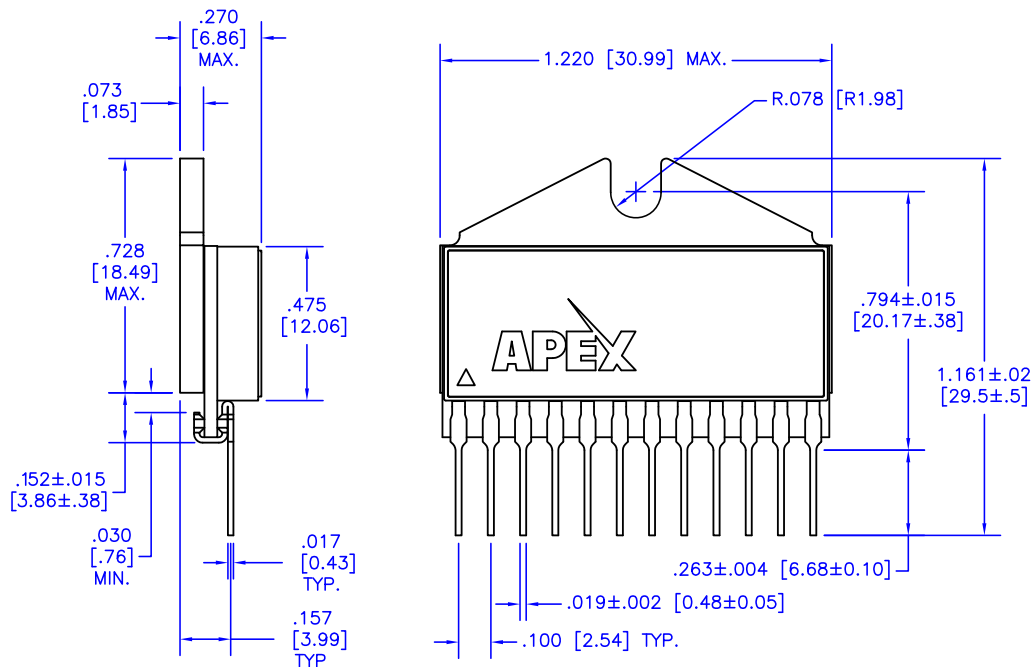
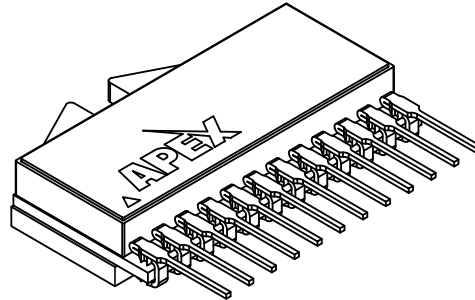

NOTES:

1. Dimensions are inches & [mm].
2. Triangle on lid denotes pin 1.
3. Pins: Alloy 510 phosphor bronze plated with matte tin (150 – 300 μ) over nickel (50 μ max.) underplate.
4. Package: Vectra liquid crystal polymer, black
5. Epoxy-sealed & ultrasonically welded non-hermetic package.
6. Package weight: .367 oz. [11.41 g]