

PCA8546

4 x 44 automotive LCD driver

Rev. 2 — 29 September 2021

Product data sheet

1 General description

The PCA8546 is a peripheral device which generates the drive signals for any multiplexed LCD containing up to four backplanes, and up to 176 elements. The PCA8546 is compatible with most microcontrollers and communicates via the two-line bidirectional I²C-bus (PCA8546A) or a three line unidirectional SPI-bus (PCA8546B). Communication overheads are minimized using a display RAM with auto-incremented addressing.

For a selection of NXP LCD segment drivers, see [Table 37](#).

2 Features and benefits

- AEC-Q100 grade 3 compliant for automotive applications
- Single-chip 176 elements LCD controller and driver
- Wide range for digital power supply: from 1.8 V to 5.5 V
- LCD supply range from 2.5 V up to 9 V
- LCD and logic supplies may be separated
- Low power consumption
- Four backplanes and selectable display bias configuration
- On-chip RAM for display data storage
- 400 kHz I²C-bus interface (PCA8546A)
- 5 MHz SPI-bus interface (PCA8546B)
- Programmable frame frequency in the range of 60 Hz to 300 Hz in steps of about 10 Hz; factory calibrated
- 176 segments driven allowing:
 - up to 22 7-segment alphanumeric characters
 - up to 11 14-segment alphanumeric characters
 - any graphics of up to 176 elements
- Manufactured in silicon gate CMOS process
- Extended operating temperature range up to 95 °C

3 Applications

- Climate control
- Car radio
- Dashboard display



4 Ordering information

Table 1. Ordering information

Type number	Interface type	Topside mark	Package		Version
			Name	Description	
PCA8546ATT/A	I ² C-bus	PCA8546ATT	TSSOP56	plastic thin shrink small outline package; 56 leads; body width 6.1 mm	SOT364-1
PCA8546BTT/A	SPI-bus	PCA8546BTT	TSSOP56	plastic thin shrink small outline package; 56 leads; body width 6.1 mm	SOT364-1

4.1 Ordering options

Table 2. Ordering options

Type number	Orderable part number	Package	Packing method ^[1]	Minimum order quantity	Temperature
PCA8546ATT/A	PCA8546ATT/AJ ^[2]	TSSOP56	reel 13 inch q1 non dry pack	2000	T _{amb} = -40 °C to +95 °C
	PCA8546ATT/AY	TSSOP56	reel 13 inch q1 dry pack	2000	T _{amb} = -40 °C to +95 °C
PCA8546BTT/A	PCA8546BTT/AJ ^[3]	TSSOP56	reel 13 inch q1 non dry pack	2000	T _{amb} = -40 °C to +95 °C
	PCA8546BTT/AY	TSSOP56	reel 13 inch q1 dry pack	2000	T _{amb} = -40 °C to +95 °C

[1] Standard packing quantities and other packaging data are available at www.nxp.com/packages/.

[2] Discontinuation Notice 202107021DN - drop in replacement is PCA8546ATT/AY - this is documented in PCN202102010F01.

[3] Discontinuation Notice 202107021DN - drop in replacement is PCA8546BTT/AY - this is documented in PCN202102010F01.

5 Block diagram

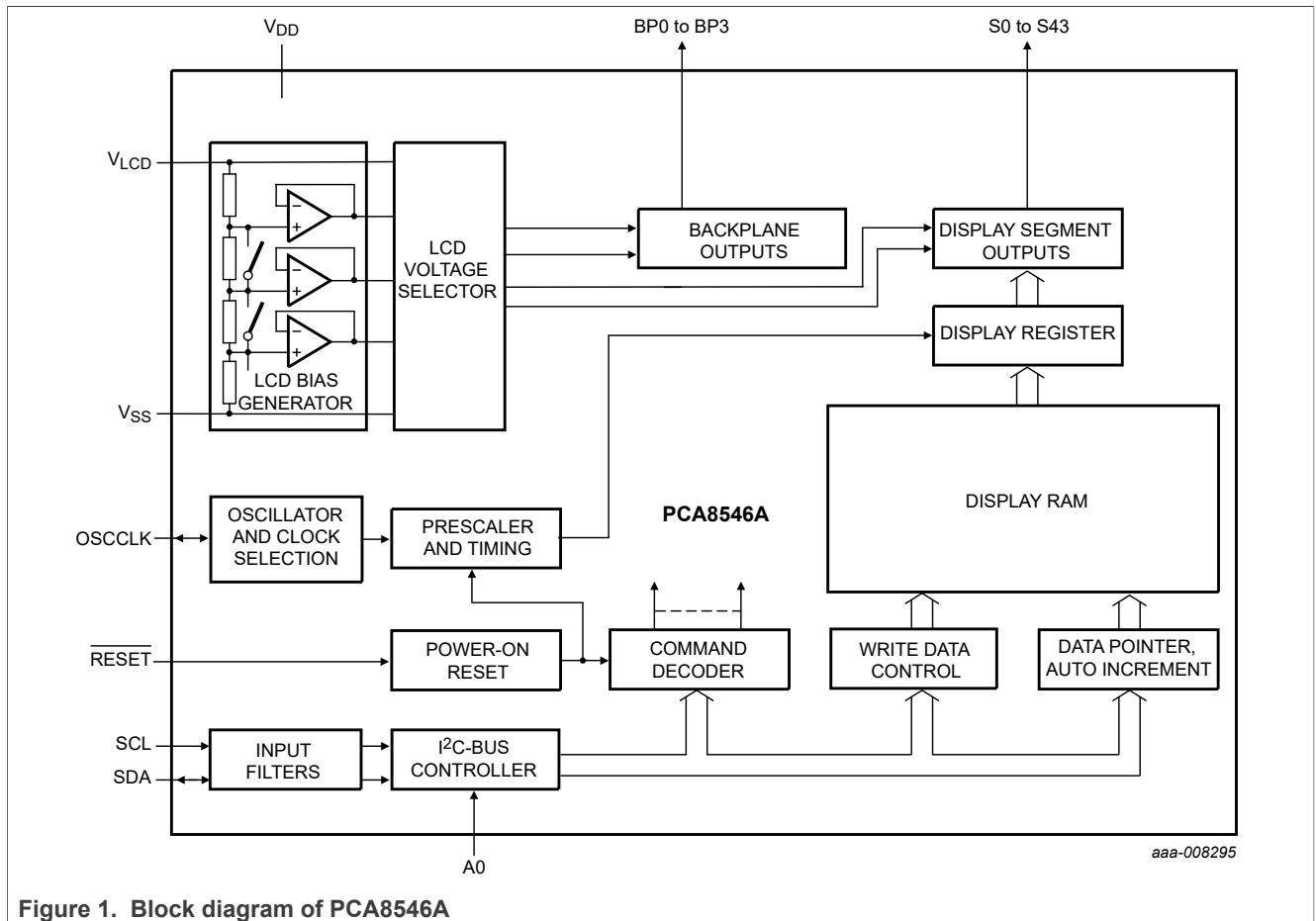

Figure 1. Block diagram of PCA8546A

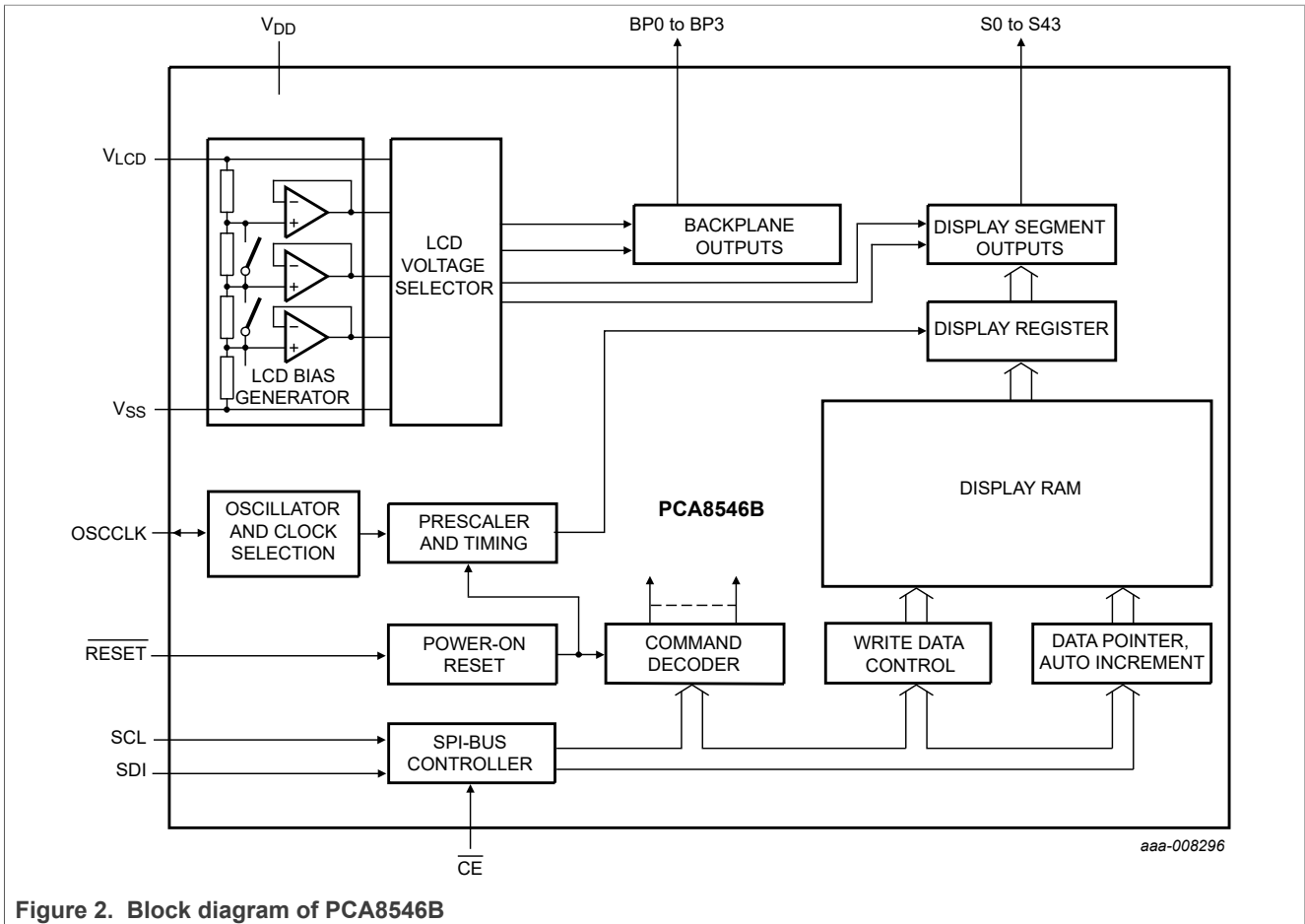
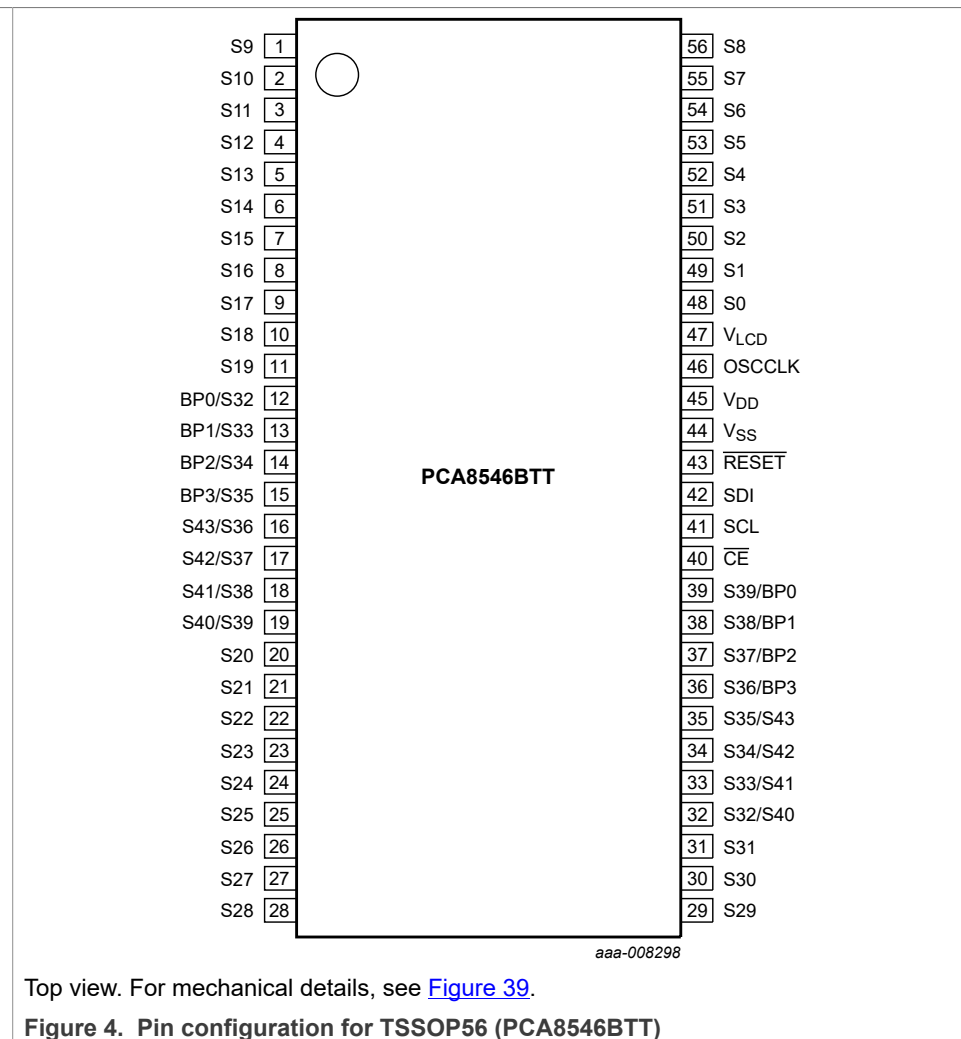
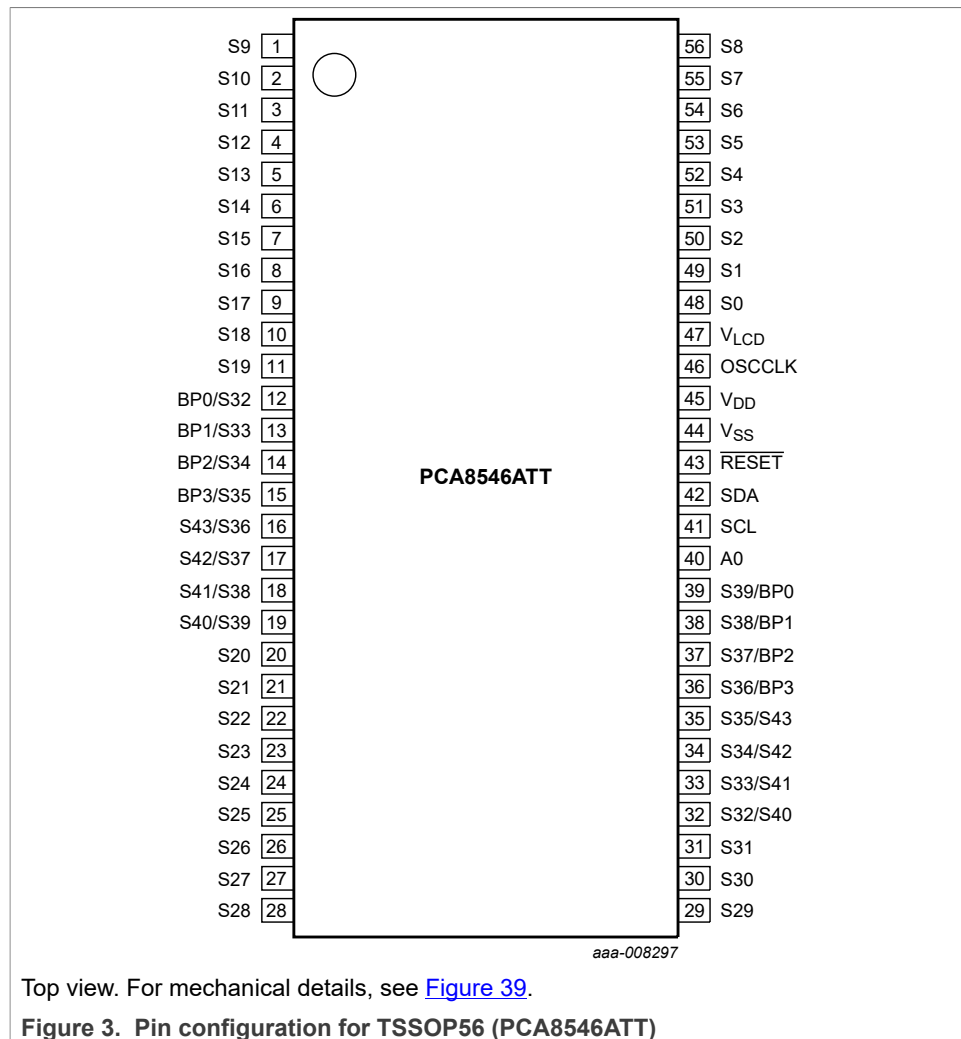

Figure 2. Block diagram of PCA8546B

6 Pinning information

6.1 Pinning



6.2 Pin description

Table 3. Pin description of PCA8546ATT and PCA8546BTT

Input or input/output pins must always be at a defined level (V_{SS} or V_{DD}) unless otherwise specified.

Pin	Symbol	Type	Description	
1 to 11	S9 to S19	output	LCD segment	
20 to 31	S20 to S31	output	LCD segment	
43	RESET	input	active LOW reset input	
44	V_{SS}	supply	ground supply voltage	
45	V_{DD}	supply	supply voltage	
46	OSCCLK	input/output	external clock input/internal oscillator output	
47	$V_{LCD}^{[1]}$	supply	LCD supply voltage	
48 to 56	S0 to S8	output	LCD segment	
Pin layout depending on backplane swap configuration^[2]				
	BPS = 0^[3]	BPS = 1		
12	BP0	S32	output LCD backplane/LCD segment	
13	BP1	S33		
14	BP2	S34		
15	BP3	S35		
16	S43	S36		
17	S42	S37		
18	S41	S38		
19	S40	S39		
32	S32	S40		
33	S33	S41		
34	S34	S42		
35	S35	S43		
36	S36	BP3		
37	S37	BP2		
38	S38	BP1		
39	S39	BP0		
Pin layout depending on product and bus type				
	PCA8546ATT	PCA8546BTT		
40	A0		input I^2C -bus target address selection	
		\overline{CE}	input SPI-bus chip enable - active LOW	
41	SCL		input I^2C -bus serial clock	
		SCL	input SPI-bus serial clock	

Table 3. Pin description of PCA8546ATT and PCA8546BTT...continued
 Input or input/output pins must always be at a defined level (V_{SS} or V_{DD}) unless otherwise specified.

Pin	Symbol	Type	Description
42	SDA	input/output	I ² C-bus serial data
	SDI	input	SPI-bus data input

- [1] V_{LCD} must be equal to or greater than V_{DD} .
 [2] Effect of backplane swapping is illustrated in [Figure 5](#).
 [3] Bit BPS is explained in [Section 7.1.3](#).

7 Functional description

The PCA8546 is a versatile peripheral device designed to interface any microcontroller to a wide variety of LCDs. It can directly drive any multiplexed LCD containing four backplanes and up to 44 segments.

7.1 Commands of PCA8546

The PCA8546 is controlled by 8 commands, which are defined in [Table 4](#). Any other combinations of operation code bits that are not mentioned in this document may lead to undesired operation modes of PCA8546.

Table 4. Commands of PCA8546

Command name	Register selection RS[1:0] ^[1]		Bits								Reference	
			7	6	5	4	3	2	1	0		
initialize												Section 7.1.1
initialize-MSB	0	0	0	0	0	1	0	1	1	0		
initialize-LSB	0	0	0	0	0	0	0	0	1	1		
OTP-refresh	0	0	1	1	1	1	0	0	0	0		Section 7.1.2
mode-settings	0	0	0	1	0	1	BPS	INV	PD	E		Section 7.1.3
oscillator-control	0	0	0	0	0	1	1	EFR	COE	OSC		Section 7.1.4
set-bias-mode	0	0	0	0	0	0	0	1	B[1:0]			Section 7.1.5
frame-frequency	0	0	0	0	1	FD[4:0]						Section 7.1.6
load-data-pointer	0	0	1	0	DP[5:0]							Section 7.1.7
write-RAM-data	0	1	D[7:0]									Section 7.1.8

[1] Information about control byte and register selection see [Section 8.1](#).

7.1.1 Command: initialize

This command generates a chip-wide reset. It consists of two bytes which have to be sent both to the device.

Table 5. Initialize - initialize command bit description

Bit	Symbol	Value	Description
Initialize-MSB			

Table 5. Initialize - initialize command bit description...continued

Bit	Symbol	Value	Description
7 to 0	-	0001 0110	fixed value
Initialize-LSB			
7 to 0	-	0000 0011	fixed value

7.1.2 Command: OTP-refresh

During production of the device, each IC is calibrated to achieve the specified accuracy of the frame frequency. This calibration is performed on EPROM cells called One Time Programmable (OTP) cells. The device reads these cells every time the OTP-refresh command is sent. The OTP-refresh command has to be sent after a reset has been made and before the display is enabled.

This command will be completed after a maximum of 30 ms and requires either the internal or external clock to run. If the internal oscillator is not used, then a clock must be supplied to the OSCCLK pin. If the OTP-refresh instruction is sent and no clock is present, then the request is stored until a clock is available.

Remark: It is recommended not to enter power-down mode during the OTP refresh cycle.

Table 6. OTP-refresh - OTP-refresh command bit description

Bit	Symbol	Value	Description
7 to 0	-	1111 0000	fixed value

7.1.3 Command: mode-settings

Table 7. Mode-settings - mode settings command bit description

Bit	Symbol	Value	Description
7 to 4	-	0101	fixed value
3	BPS		backplane swapping
		0 ^[1]	backplane configuration 0
		1	backplane configuration 1
2	INV		set inversion mode
		0 ^{[1][2]}	Driving scheme A: LCD line inversion mode
		1	Driving scheme B: LCD frame inversion mode
1	PD		set power mode
		1	power-down mode; backplane and segment outputs are connected to V _{SS} and the internal oscillator is switched off
		0 ^[1]	power-up mode
0	E		display switch
		0 ^[1]	display disabled; backplane and segment outputs are connected to V _{SS}
		1	display enabled

[1] Default value.
 [2] See [Section 7.1.3.2](#).

7.1.3.1 Backplane swapping

Backplane swapping can be configured with the BPS bit (see [Table 7](#)). It moves the location of the backplane and the associated segment outputs from one side of the PCA8546 to the other. Backplane swapping is sometimes desirable to aid with the routing of PCBs that do not use multiple layers.

The BPS bit has to be set to the required value before enabling the display. Failure to do so does not damage the PCA8546 or the display, however unexpected display content may appear.

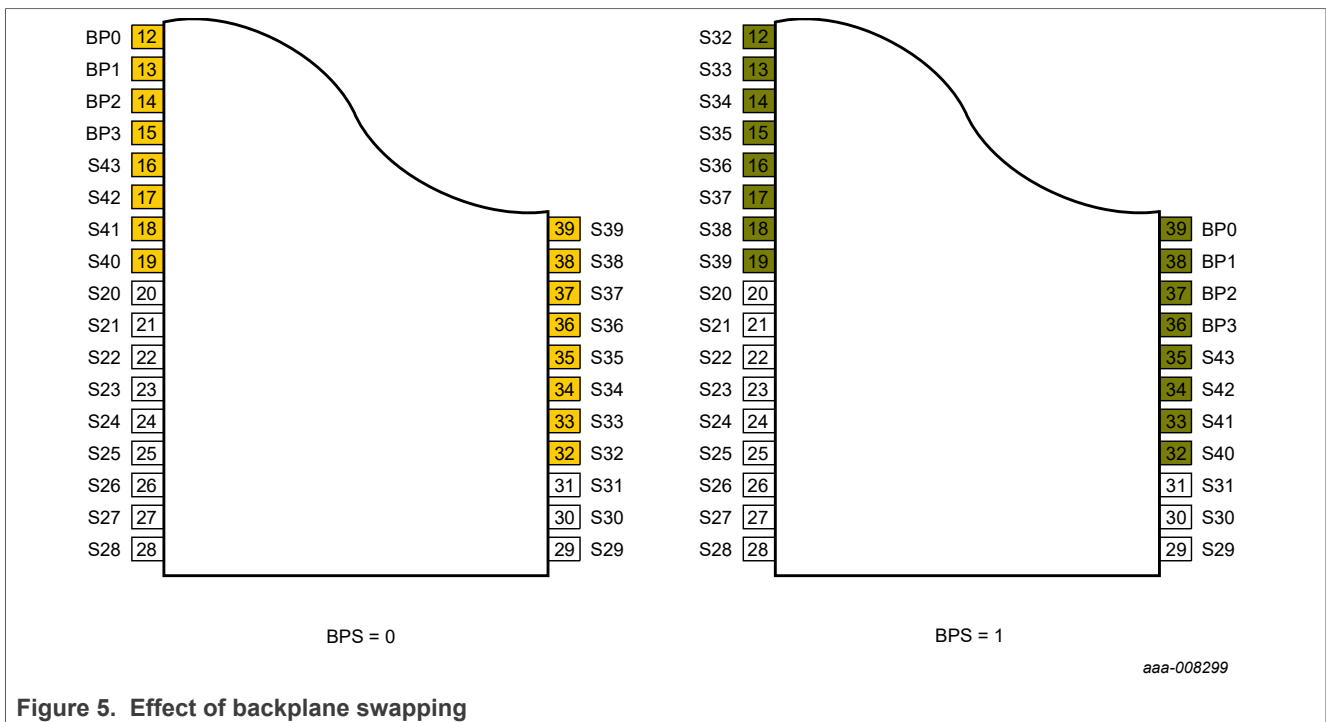

Figure 5. Effect of backplane swapping

7.1.3.2 Line inversion (driving scheme A) and frame inversion (driving scheme B)

The DC offset of the voltage across the LCD is compensated over a certain period: line-wise in line inversion mode (driving scheme A) or frame-wise in frame inversion mode (driving scheme B). With the INV bit (see [Table 7](#)), the compensation mode can be switched.

In frame inversion mode, the DC value is compensated across two frames and not within one frame. Changing the inversion mode to frame inversion reduces the power consumption; therefore it is useful when power consumption is a key point in the application.

Frame inversion may not be suitable for all applications. The RMS voltage across a segment is better defined; however, since the switching frequency is reduced, there is possibility for flicker to occur.

The waveforms of [Figure 14](#) shows the line inversion mode. [Figure 15](#) shows the frame inversion mode.

7.1.3.3 Power-down mode

The power-down bit (PD) allows the PCA8546 to be put in a minimum power configuration. To avoid display artifacts, enter power-down only after the display has been switched off by setting bit E to logic 0. During power-down, the internal oscillator is switched off.

Table 8. Effect of the power-down bit (PD)

Effect on function	Mode settings	Effect of setting PD	
		0	1
backplane output	E = 1	normal function	V _{SS}
segment output	E = 1	normal function	V _{SS}
internal oscillator	OSC = 0, COE = 1	on	off
OSCCLK pin	OSC = 0, COE = 1	output of internal oscillator frequency	V _{DD}
OSCCLK pin	OSC = 1	input clock	clock input, can be logic 0, logic 1, or left floating

With the following sequence, the PCA8546 can be set to a state of minimum power consumption, called power-down mode.

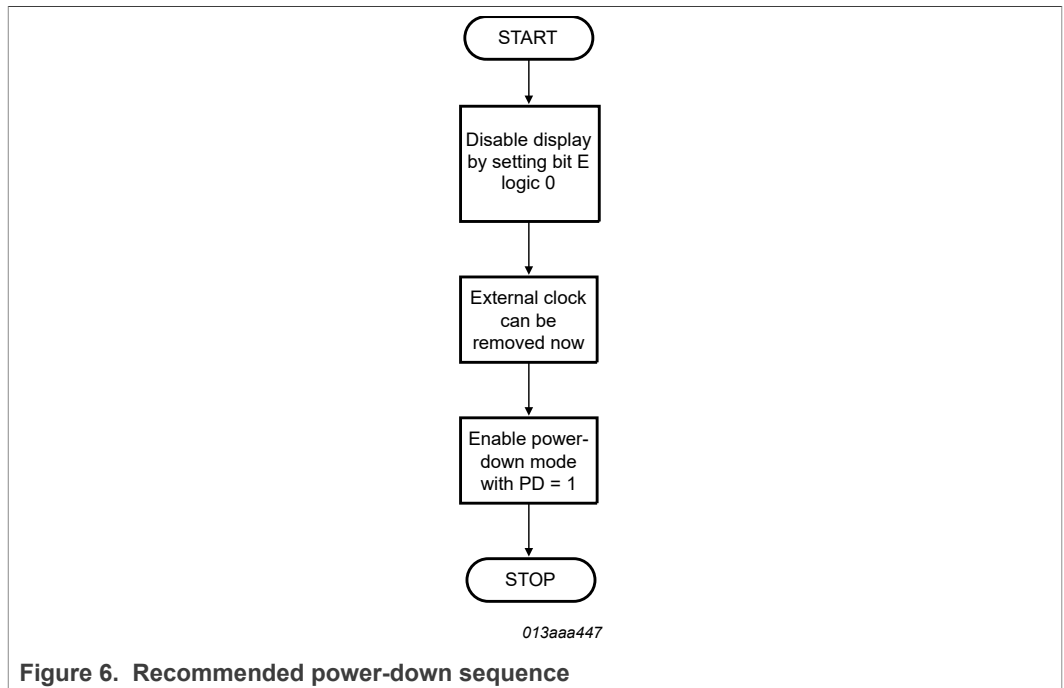

Figure 6. Recommended power-down sequence

Remarks:

- It is necessary to run the power-down sequence before removing the supplies. Depending on the application, care must be taken that no other signals are present at the chip input or output pins when removing the supplies (see Section 9). Otherwise it may cause unwanted display artifacts. If an uncontrolled removal of the supply happens, the PCA8546 does not get damaged.

- Static voltages across the liquid crystal display can build up when the external LCD supply voltage (V_{LCD}) is on while the IC supply voltage is off, or the other way around. This may cause unwanted display artifacts. To avoid such artifacts, V_{LCD} and V_{DD} must be applied or removed together.
- A clock signal must always be supplied to the device when the display is active. Removing the clock may freeze the LCD in a DC state, which is not suitable for the liquid crystal. First disable the display and afterwards remove the clock signal.

7.1.3.4 Display enable

The display enable bit (E) is used to enable and disable the display. When the display is disabled, all LCD outputs go to V_{SS} . This function is implemented to ensure that no voltage can be induced on the LCD outputs as it may lead to unwanted displays of segments.

Recommended start-up sequences are found in [Section 7.2.3](#)

Remark: Display enable is not synchronized to an LCD frame boundary. Therefore using this function to flash a display for prolonged periods is not recommended due to the possible build-up of DC voltages on the display.

7.1.4 Command: oscillator-control

The oscillator-control command switches between internal and external oscillator and enables or disables the pin OSCCLK. It is also defines the external frequency.

Table 9. Oscillator-control - oscillator control command bit description

Bit	Symbol	Value	Description
7 to 3	-	0001 1	fixed value
2	EFR		external clock frequency applied on pin OSCCLK
		0 ^[1]	9.6 kHz
		1	230 kHz
1	COE		clock output enable for pin OSCCLK
		0 ^[1]	clock signal not available on pin OSCCLK; pin OSCCLK is in 3-state
		1	clock signal available on pin OSCCLK
0	OSC		oscillator source
		0 ^[1]	internal oscillator running
		1	external oscillator used; pin OSCCLK becomes an input; used in combination with EFR to determine input frequency

[1] Default value.

The bits OSC, COE, and EFR control the source and frequency of the clock used to generate the LCD signals (see [Figure 7](#)). Valid combinations are shown in [Table 10](#).

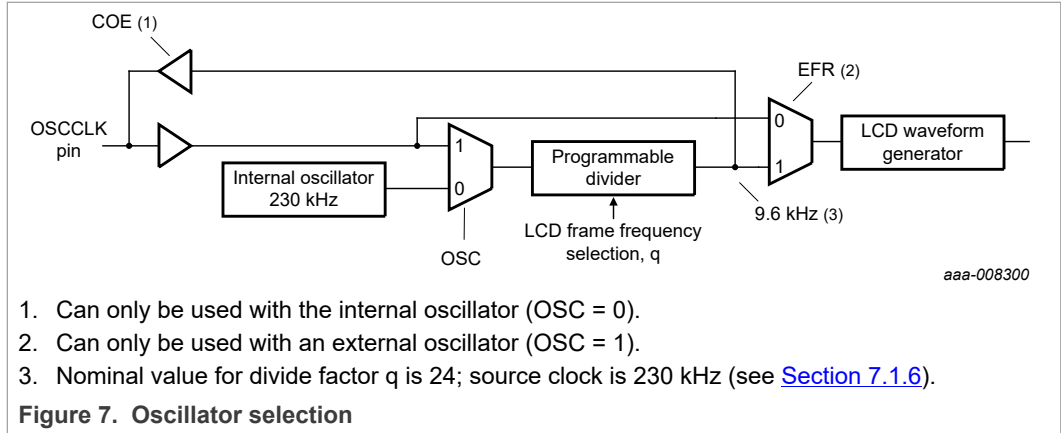

Table 10. Valid combinations of bits OSC, EFR, and COE

OSC	COE	EFR	OSCCLK pin	Clock source
0	0	not used	inactive; may be left floating	internal oscillator used
0	1	not used	output of internal oscillator frequency (prescaler)	internal oscillator used
1	not used	0	9.6 kHz input	OSCCLK pin
1	not used	1	230 kHz input	OSCCLK pin

Table 11. Typical use of bits OSC, EFR, and COE

Usage	OSC	COE	EFR
LCD with internal oscillator	0	0	not used
LCD with external oscillator (230 kHz)	1	not used	1
LCD with external oscillator (9.6 kHz)	1	not used	0

7.1.4.1 Oscillator

The system is designed to operate from a 9.6 kHz or a 230 kHz clock. This clock can be sourced internally or externally. The internal logic and LCD drive signals of the PCA8546 are timed either by the internal oscillator or from the clock externally supplied.

Internal clock

When the internal oscillator is used, all LCD signals are generated from it. The oscillator runs at nominal 230 kHz. The relationship between this frequency and the LCD frame frequency is detailed in [Section 7.1.6](#). Control over the internal oscillator is made with the OSC bit (see [Section 7.1.4](#)).

It is possible to make the internal oscillator signal available on pin OSCCLK by using the oscillator-control command (see [Table 9](#)) and configuring the clock output enable (COE) bit. If not required, the pin OSCCLK should be left open or connected to V_{SS}. At power-on the signal at pin OSCCLK is disabled and pin OSCCLK is in 3-state.

Clock output is only valid when using the internal oscillator. The signal appears on the OSCCLK pin.

An intermediate clock frequency is available at the OSCCLK pin. The duty cycle of this clock varies with the chosen divide ratio.

Table 12. OSCCLK pin state depending on configuration

PD	OSC	COE	EFR	OSCCLK pin ^[1]
power-down	n.a.	off	n.a.	3-state ^[2]
power-down	n.a.	on	n.a.	V _{DD}
power-up	internal oscillator	off	n.a.	3-state
		on	n.a.	9.6 kHz output ^[3]
	external oscillator	n.a.	9.6 kHz	9.6 kHz input
			230 kHz	230 kHz input

[1] When $\overline{\text{RESET}}$ is active, the pin OSCCLK is in 3-state.
 [2] In this state, an external clock may be applied, but it is not a requirement.
 [3] 9.6 kHz is the nominal frequency with q = 24, see [Table 13](#).

External clock

In applications where an external clock must be applied to the PCA8546, bit OSC (see [Table 9](#)) has to be set logic 1. In this case pin OSCCLK becomes an input.

The OSCCLK signal must switch between the V_{SS} and the V_{DD} voltage supplied to the chip.

The EFR bit determines the external clock frequency (230 kHz or 9.6 kHz). The clock frequency (f_{clk(ext)}) in turn determines the LCD frame frequency, see [Table 13](#).

Remark: If an external clock is used, then this clock signal must always be supplied to the device when the display is on. Removing the clock may freeze the LCD in a DC state which damages the LCD material.

7.1.4.2 Timing and frame frequency

The timing of the PCA8546 organizes the internal data flow of the device. This includes the transfer of display data from the display RAM to the display segment outputs. The timing also generates the LCD frame frequency which it derives as an integer division of the clock frequency (see [Table 13](#)). The frame frequency is a fixed division of the internal clock or of the frequency applied to pin OSCCLK when an external clock is used.

Table 13. LCD frame frequencies

Frame frequency	Typical external frequency (Hz)	Nominal frame frequency (Hz)	EFR bit	Value of q ^[1]
$f_{fR(LCD)} = \frac{f_{clk(ext)}}{48}$	9 600	200	0	-
$f_{fR(LCD)} = \frac{f_{clk(ext)}}{48q}$	230 000	200	1	24

[1] Other values of the frame frequency prescaler see [Table 16](#).

When the internal clock is used, or an external clock with EFR = 1, the LCD frame frequency can be programmed by software in steps of approximately 10 Hz in the range of 60 Hz to 300 Hz (see [Table 16](#)). Furthermore the internal oscillator is factory calibrated, see [Table 31](#).

7.1.5 Command: set-bias-mode

The set-bias-mode command allows setting the bias level.

Table 14. Set-bias-mode - set bias mode command bit description

Bit	Symbol	Value	Description
7 to 2	-	0000 01	fixed value
1 to 0	B[1:0]	00 ^[1] . 01	1/4 bias
		11	1/3 bias
		10	1/2 bias

[1] Default value.

7.1.6 Command: frame-frequency

With the frame-frequency command, the frame frequency for the display can be configured. The clock frequency determines the frame frequency.

Table 15. Frame-frequency - frame frequency and output clock frequency command bit description

Bit	Symbol	Value	Description
7 to 5	-	001	fixed value
4 to 0	FD[4:0]	see Table 16	frequency prescaler

When using an **external clock** it can be either a 230 kHz or a 9.6 kHz clock signal. The EFR bit (see [Table 9](#)) has to be set according to the external clock frequency.

When EFR is set to 9.6 kHz, then the LCD frame frequency is calculated with [Equation 1](#):

$$f_{fr(LCD)} = \frac{f_{clk(ext)}}{48} \quad (1)$$

When EFR is set to 230 kHz, then the LCD frame frequency is calculated with [Equation 2](#):

$$f_{fr(LCD)} = \frac{f_{clk(ext)}}{48q} \quad (2)$$

where q is the frequency divide factor (see [Table 16](#)).

Remark: $f_{clk(ext)}$ is the external input clock frequency to pin OSCCLK.

When the **internal oscillator** is used, the intermediate frequency may be output on the OSCCLK pin. Its frequency is given in [Table 16](#).

Table 16. Frame frequency prescaler values for 230 kHz clock operation

FD[4:0]	Nominal LCD frame frequency (Hz) ^[1]	Divide factor, q	Intermediate clock frequency (Hz)
0 0000	59.9	80	2 875

Table 16. Frame frequency prescaler values for 230 kHz clock operation...continued

FD[4:0]	Nominal LCD frame frequency (Hz) ^[1]	Divide factor, q	Intermediate clock frequency (Hz)
0 0001	70.5	68	3 382
0 0010	79.9	60	3 833
0 0011	90.4	53	4 340
0 0100	99.8	48	4 792
0 0101	108.9	44	5 227
0 0110	119.8	40	5 750
0 0111	129.5	37	6 216
0 1000	140.9	34	6 765
0 1001	149.7	32	7 188
0 1010	159.7	30	7 667
0 1011	171.1	28	8 214
0 1100	177.5	27	8 519
0 1101	191.7	25	9 200
0 1110 ^[2]	199.7	24	9 583
0 1111	208.3	23	10 000
1 0000	217.8	22	10 455
1 0001	228.3	21	10 952
1 0010	239.6	20	11 500
1 0011	252.2	19	12 105
1 0100	266.2	18	12 778
1 0101	281.9	17	13 529
1 0110	299.5	16	14 375
1 0111 to 1 1111	not used		

[1] Nominal frame frequency calculated for the default clock frequency of 230 kHz.

[2] Default value.

7.1.7 Command: load-data-pointer

The load-data-pointer command defines the start address of the display RAM, see [Table 17](#). The data pointer is auto incremented after each RAM write.

Table 17. Load-data-pointer - load data pointer command bit description

Bit	Symbol	Value	Description
7 to 6	-	10	fixed value
5 to 0	DP[5:0]	00 0000 ^[1] to 10 1011	6-bit binary value of 0 to 43

[1] Default value.

Remark: Data pointer values outside of the valid range are ignored and no RAM content is transferred until a valid data pointer value is set.

Filling of the display RAM is described in [Section 7.9](#).

7.1.8 Command: write-RAM-data

This command initiates the transfer of data to the display RAM. Data is written into the address defined by the load-data-pointer command. RAM filling is described in [Section 7.9](#).

Table 18. Write-RAM-data - write RAM data command bit description

For this command to be effective bit RS[1:0] of the control byte has to be set logic 01, see [Table 22 on page 29](#).

Bit	Symbol	Value	Description
7 to 0	D[7:0]	0000 0000 to 1111 1111	writing data byte-wise to RAM

7.2 Start-up and shut-down

7.2.1 Reset and Power-On Reset (POR)

After power-on the PCA8546 has to be initialized by sending the two bytes of the initialize command (see [Section 7.1.1](#) and [Table 5](#)).

After a reset and the initialization the starting conditions of the PCA8546 are as follows:

1. The display is disabled.
2. All backplane and segment outputs are set to V_{SS} .
3. The data pointers are cleared (set logic 0).
4. RAM data is not initialized. Its content can be considered to be random.
5. The internal oscillator is running; no clock signal is available on pin OSCCLK; pin OSCCLK is in 3-state.

The state after a reset and the initialization is shown in [Table 19](#).

Table 19. Starting conditions

Associated command	Bits							
	7	6	5	4	3	2	1	0
mode-settings	-	-	-	-	BPS = 0	INV = 0	PD = 0	E = 0
oscillator-control	-	-	-	-	-	EFR = 0	COE = 0	OSC = 0
set-bias-mode	-	-	-	-	-	-	B[1:0] = 00	
frame-frequency	-	-	-	FD[4:0] = 0 1110				
load-data-pointer	-	-	DP[5:0] = 00 0000					

After Power-On Reset (POR) and the initialize command and before enabling the display, the RAM content should be brought to a defined state by writing meaningful content (for example, a graphic) otherwise unwanted display artifacts may appear on the display.

7.2.2 RESET pin function

The $\overline{\text{RESET}}$ pin sets the PCA8546 in a defined mode. The RAM content remains unchanged. After the reset signal is removed, the initialize command (see [Section 7.1.1](#) and [Table 5](#)) has to be sent to the PCA8546. See [Section 7.2.1](#) for details.

7.2.3 Recommended start-up sequences

This chapter describes how to proceed with the initialization of the chip in different application modes.

In general, the sequence should always be:

1. Power-on or reset the device,
2. send the initialize command,
3. set the display and functional modes,
4. fill the display memory and then
5. turn on the display.

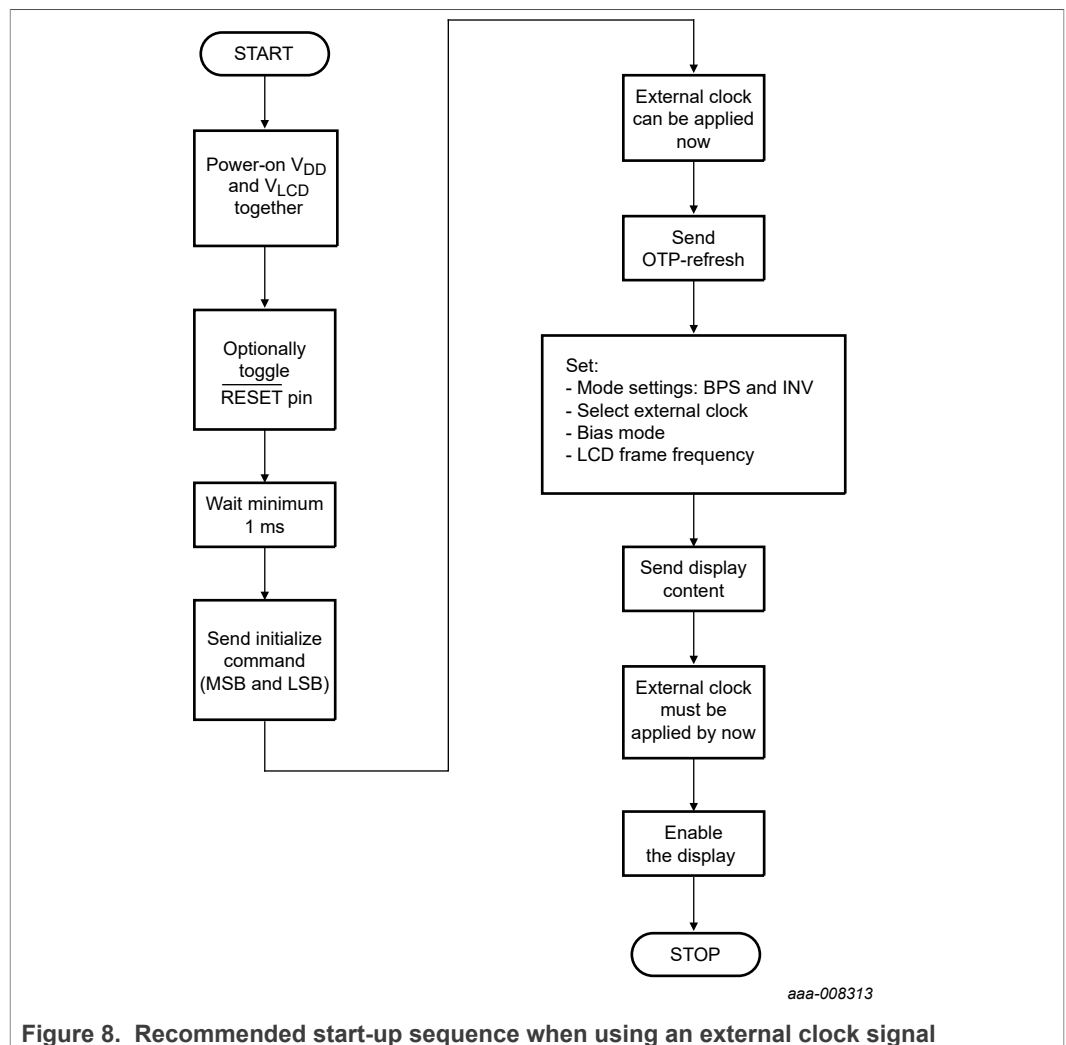
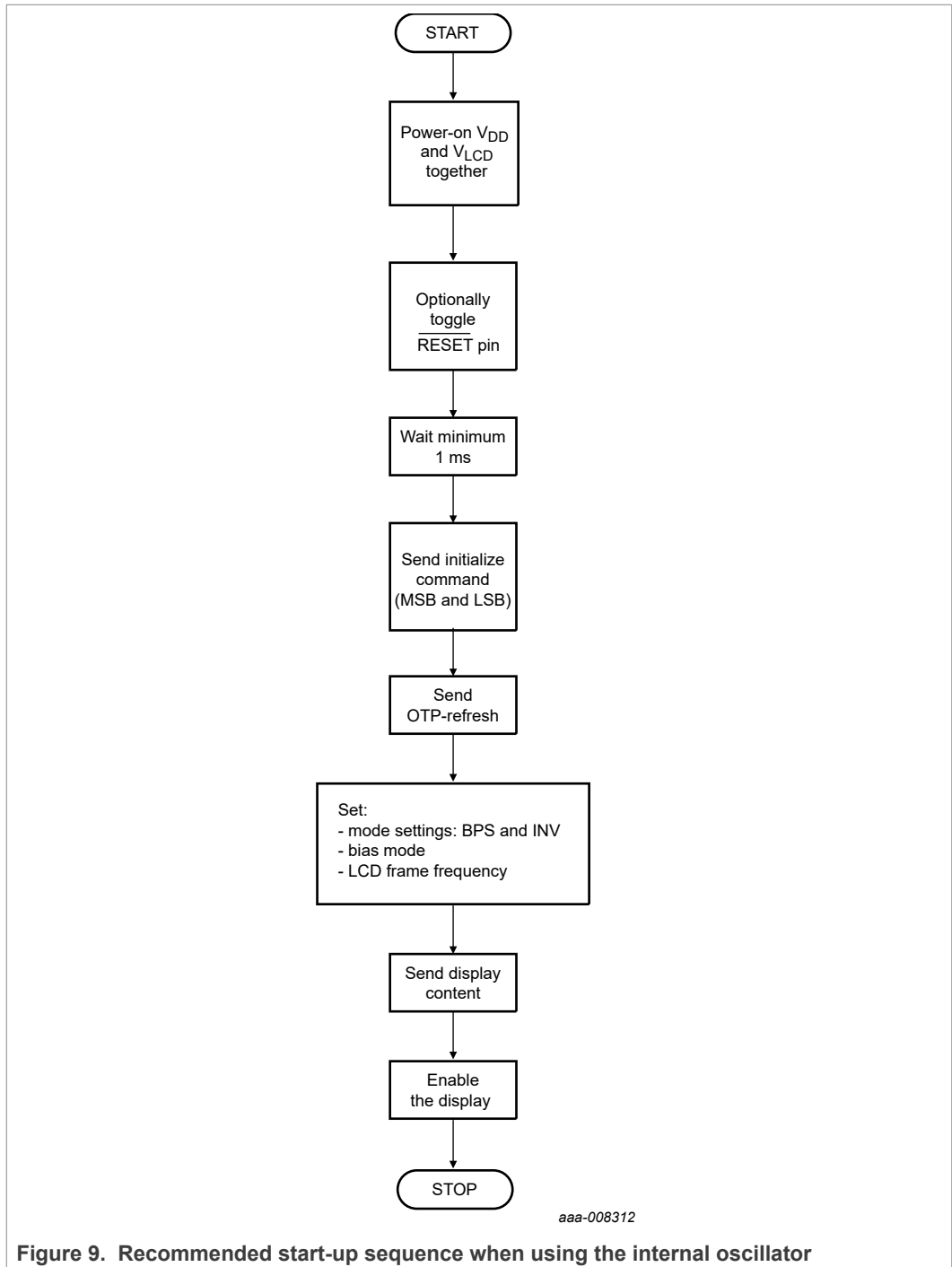

Figure 8. Recommended start-up sequence when using an external clock signal



7.3 Possible display configurations

The PCA8546 is a versatile peripheral device designed to interface between any microcontroller to a wide variety of LCD segment or dot matrix displays (see [Figure 10](#)). It can drive multiplexed LCD with 4 backplanes and up to 44 segments.

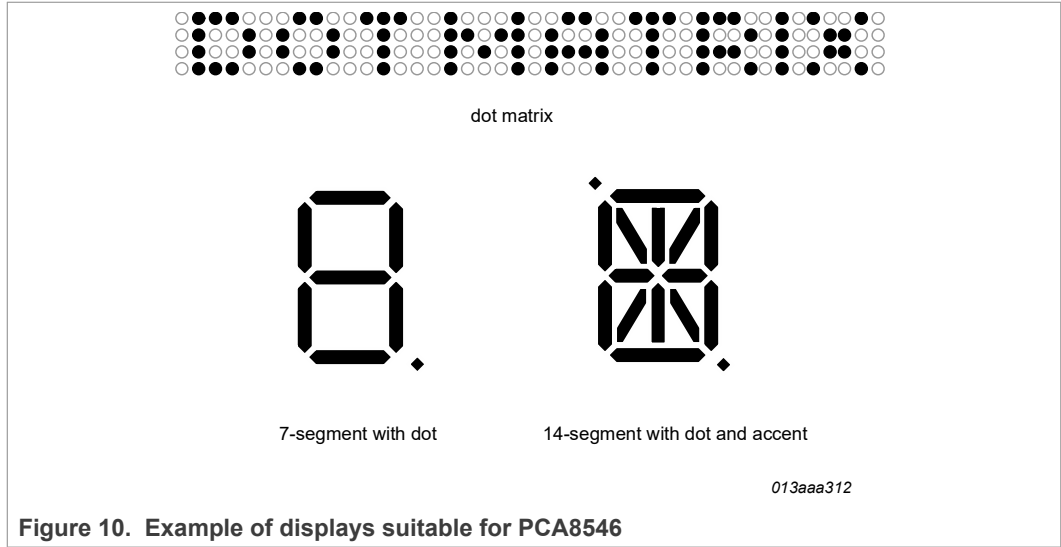

Figure 10. Example of displays suitable for PCA8546

Table 20. Display configuration

Number of			Digits/Characters		Dot matrix/ Elements
Backplanes	Segments	Icons	7 segment ^[1]	14 segment ^[2]	
4	44	176	22	11	176

[1] 7 segment display has 8 elements including the decimal point.

[2] 14 segment display has 16 elements including decimal point and accent dot.

The display configuration in [Table 20](#) can be implemented in the typical systems shown in [Figure 11](#) and [Figure 12](#).

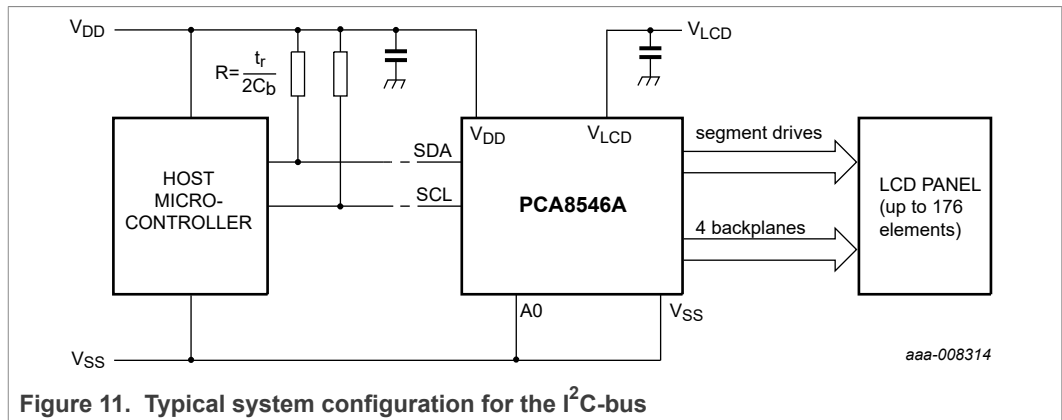
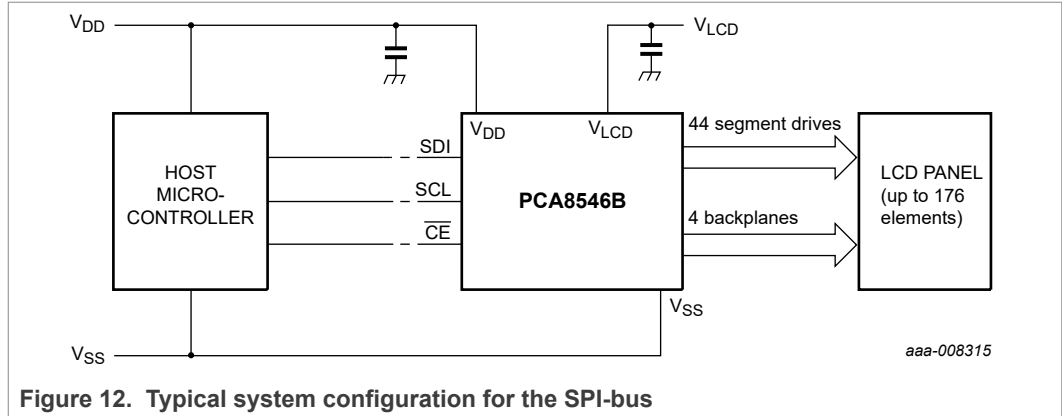

Figure 11. Typical system configuration for the I²C-bus



The host microcontroller maintains the two line I²C-bus or a three line SPI-bus communication channel with the PCA8546. The appropriate biasing voltages for the multiplexed LCD waveforms are generated internally. The only other connections required to complete the system are the power supplies (V_{DD}, V_{SS}, V_{LCD}) and the LCD panel selected for the application.

The minimum recommended values for external capacitors on V_{DD} and V_{LCD} are 100 nF respectively. Decoupling of V_{LCD} helps to reduce display artifacts. The decoupling capacitors should be placed close to the IC with short connections to the respective supply pin and V_{SS}.

7.4 LCD voltage selector

The LCD voltage selector coordinates the multiplexing of the LCD in accordance with the selected LCD drive configuration. The operation of the voltage selector is controlled by the set-bias-mode command (see Table 14).

Fractional LCD biasing voltages are obtained from an internal voltage divider. The biasing configurations, the biasing characteristics as functions of V_{LCD} and the resulting discrimination ratios (D), are given in Table 21.

Discrimination is a term which is defined as the ratio of the on and off RMS voltage across a segment. It can be thought of as a measurement of contrast.

Table 21. Preferred LCD drive modes: summary of characteristics

LCD multiplex drive mode	Number of:		LCD bias configuration	$\frac{V_{off(RMS)}}{V_{LCD}}$	$\frac{V_{on(RMS)}}{V_{LCD}}$	$D = \frac{V_{on(RMS)}}{V_{off(RMS)}}$ [1]	V _{LCD} [2]
	Backplanes	Levels					
1:4 [3]	4	3	1/2	0.433	0.661	1.527	2.309V _{off(RMS)}
1:4	4	4	1/3	0.333	0.577	1.732	3.0V _{off(RMS)}
1:4 [3]	4	5	1/4	0.331	0.545	1.646	3.024V _{off(RMS)}

[1] Determined from Equation 5.

[2] Determined from Equation 4.

[3] In these examples, the discrimination factor and hence the contrast ratios are smaller. The advantage of these LCD drive modes is a reduction of the LCD voltage V_{LCD}.

A practical value for V_{LCD} is determined by equating V_{off(RMS)} with a defined LCD threshold voltage (V_{th(off)}), typically when the LCD exhibits approximately 10 % contrast.

Bias is calculated by $\frac{1}{1+a}$, where the values for a are

- a = 1 for $\frac{1}{2}$ bias
- a = 2 for $\frac{1}{3}$ bias
- a = 3 for $\frac{1}{4}$ bias

The RMS on-state voltage ($V_{on(RMS)}$) for the LCD is calculated with [Equation 3](#)

$$V_{on(RMS)} = \frac{V_{LCD}}{n} \sqrt{\frac{a^2 + 2a + n}{1 + a^2}} \quad (3)$$

where V_{LCD} is the resultant voltage at the LCD segment and where the value for n is

- n = 4 for 1:4 multiplex drive

The RMS off-state voltage ($V_{off(RMS)}$) for the LCD is calculated with [Equation 4](#):

$$V_{off(RMS)} = \frac{V_{LCD}}{n} \sqrt{\frac{a^2 - 2a + n}{1 + a^2}} \quad (4)$$

Discrimination is the ratio of $V_{on(RMS)}$ to $V_{off(RMS)}$ and is determined from [Equation 5](#):

$$D = \frac{V_{on(RMS)}}{V_{off(RMS)}} = \sqrt{\frac{a^2 + 2a + n}{a^2 - 2a + n}} \quad (5)$$

V_{LCD} is sometimes referred to as the LCD operating voltage.

7.4.1 Electro-optical performance

Suitable values for $V_{on(RMS)}$ and $V_{off(RMS)}$ are dependent on the LCD liquid used. The RMS voltage, at which a pixel gets switched on or off, determine the transmissibility of the pixel.

For any given liquid, there are two threshold values defined. One point is at 10 % relative transmission (at $V_{th(off)}$) and the other at 90 % relative transmission (at $V_{th(on)}$), see [Figure 13](#). For a good contrast performance, the following rules should be followed:

$$V_{on(RMS)} \geq V_{th(on)} \quad (6)$$

$$V_{off(RMS)} \leq V_{th(off)} \quad (7)$$

$V_{on(RMS)}$ and $V_{off(RMS)}$ are properties of the display driver and are affected by the selection of a, n (see [Equation 3](#) to [Equation 5](#)) and the V_{LCD} voltage.

$V_{th(off)}$ and $V_{th(on)}$ are properties of the LCD liquid and can be provided by the module manufacturer. $V_{th(off)}$ is sometimes named V_{th} . $V_{th(on)}$ is sometimes named saturation voltage V_{sat} .

It is important to match the module properties to those of the driver in order to achieve optimum performance.

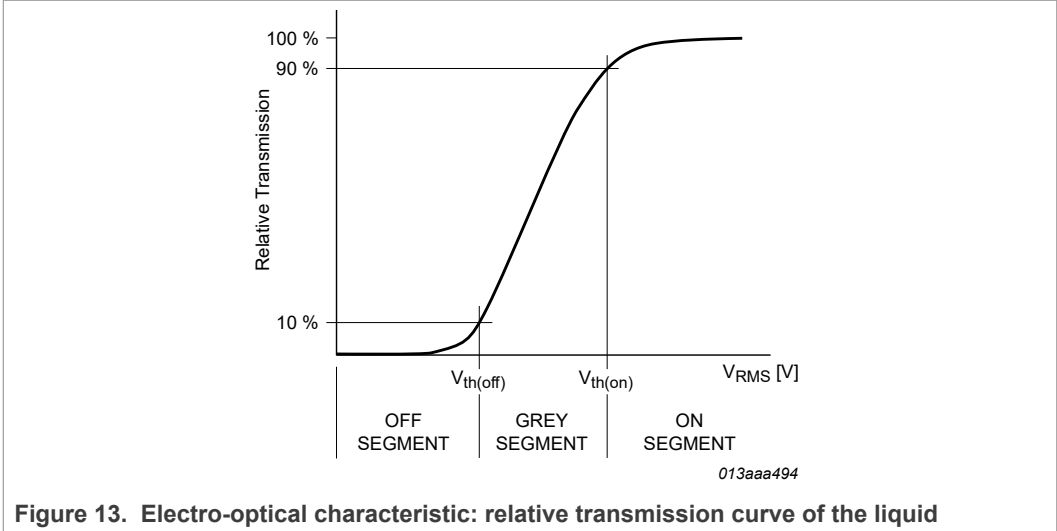

7.5 LCD drive mode waveforms

7.5.1 1/3 bias and line inversion

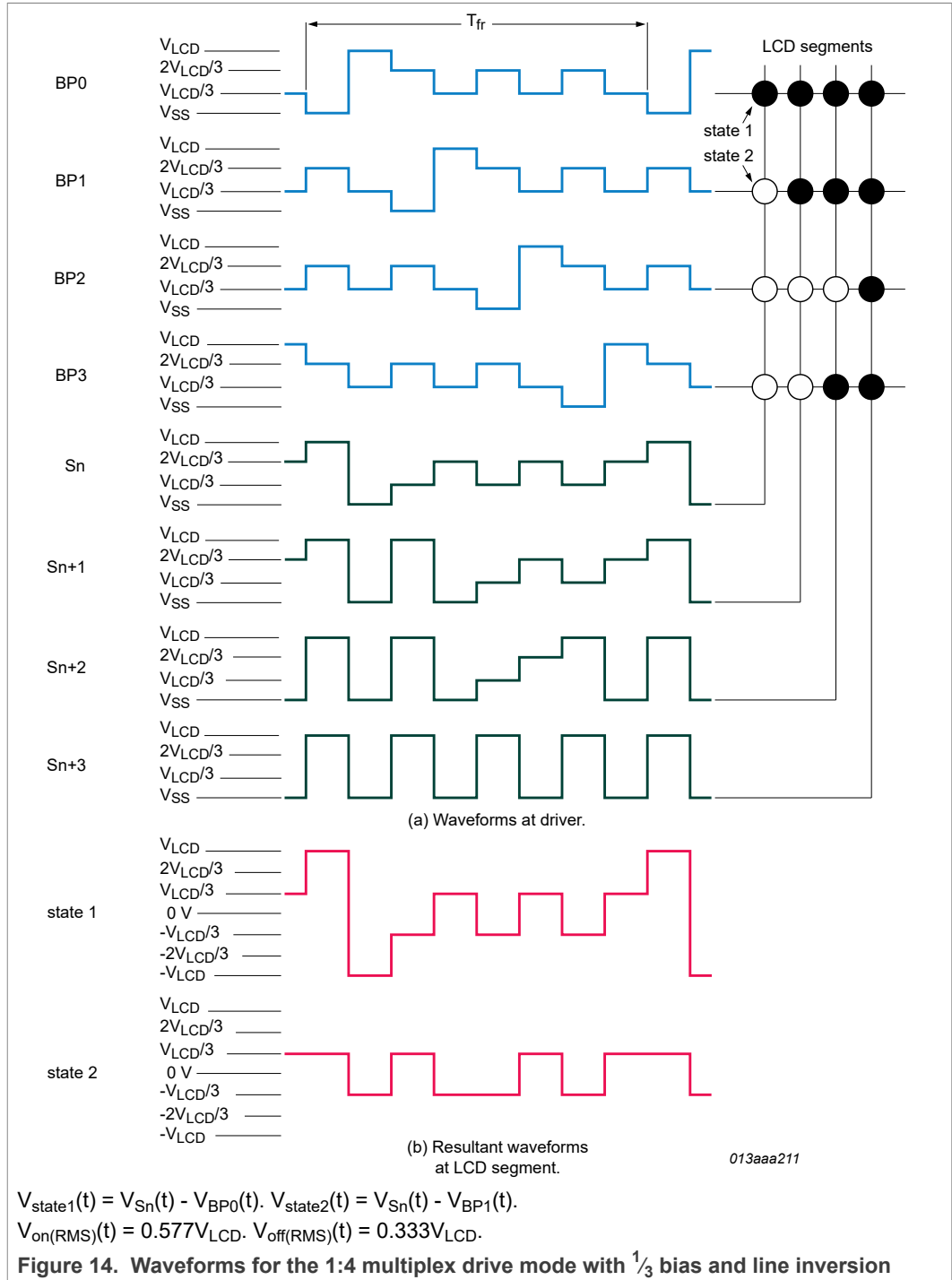

7.5.2 1/3 bias and frame inversion

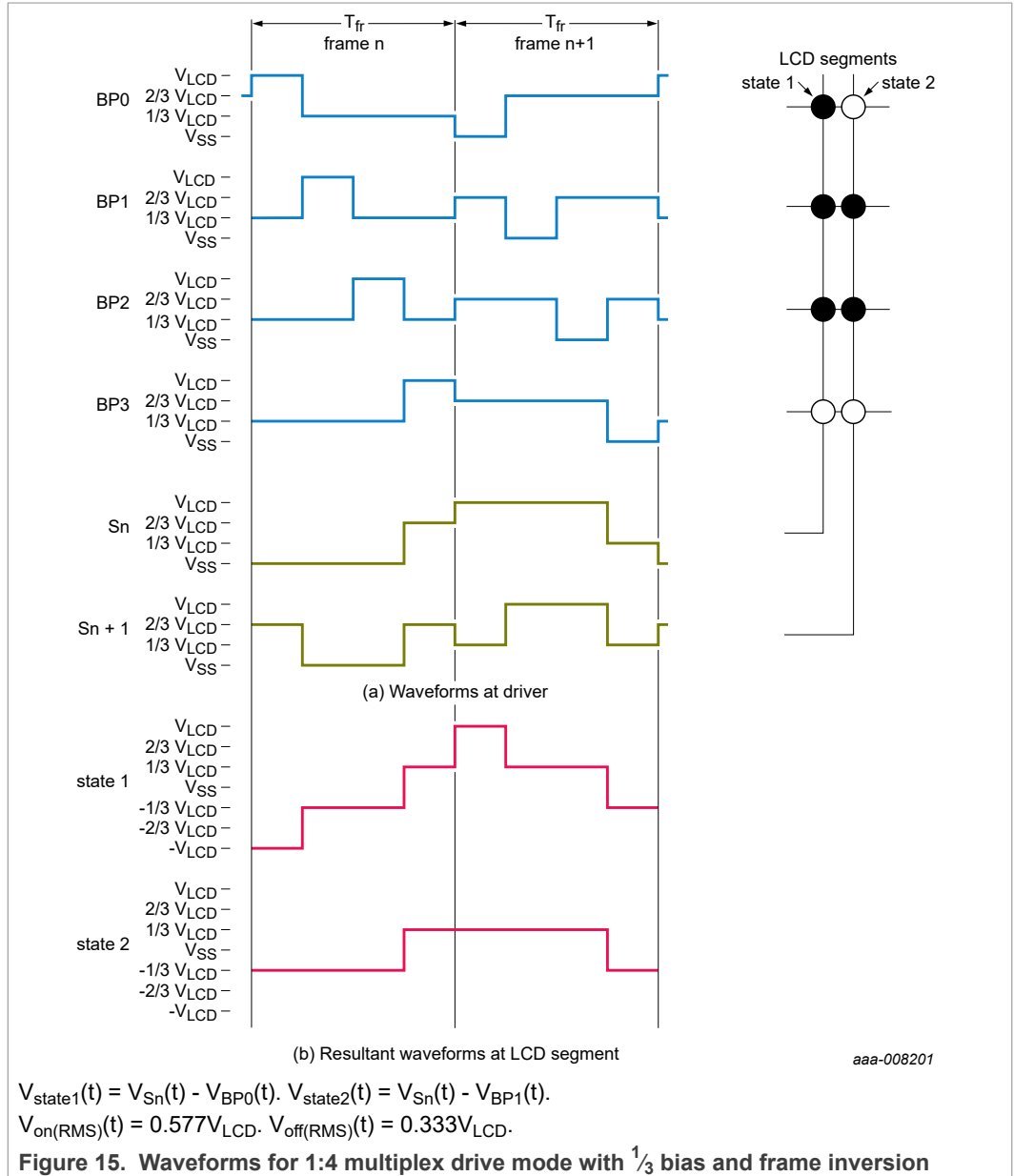

7.6 Display register

The display register holds the display data while the corresponding multiplex signals are generated.

7.7 Backplane outputs

The LCD drive section includes four backplane outputs: BP0 to BP3 which must be connected directly to the LCD.

7.8 Segment outputs

The LCD drive section includes up to 44 segment outputs (S0 to S43) which must be connected directly to the LCD. The segment output signals are generated based on the data resident in the display register. When less segment outputs are required, the unused segment outputs must be left open-circuit.

7.9 Display RAM

The display RAM stores the LCD data. The RAM size is 44 x 4 bit.

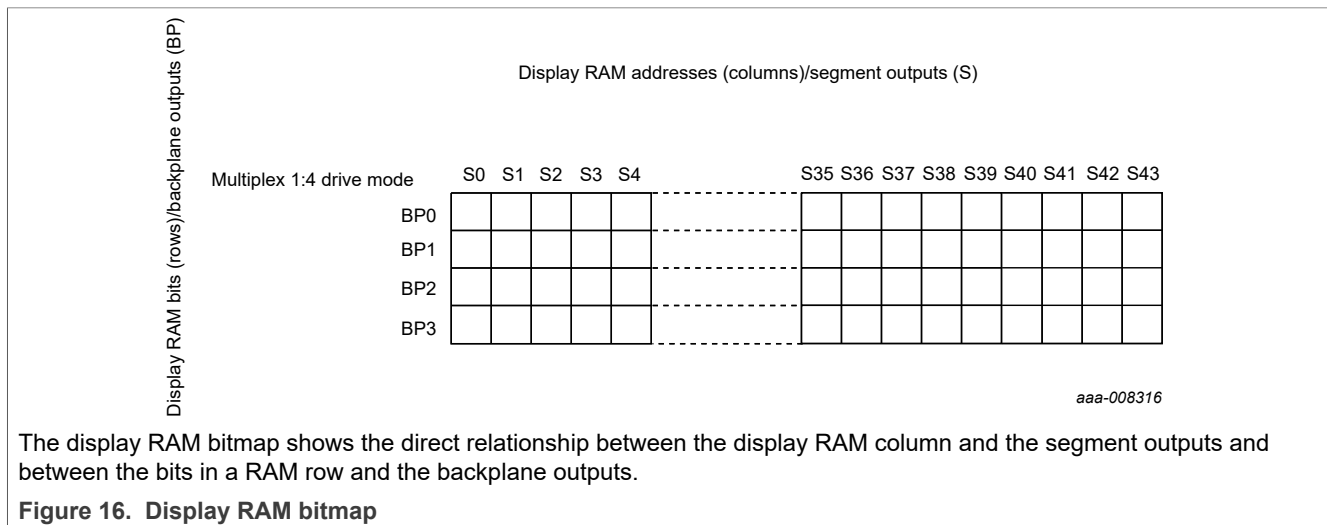

Logic 1 in the RAM bit map indicates the on-state ($V_{on(RMS)}$) of the corresponding LCD element; similarly, logic 0 indicates the off-state ($V_{off(RMS)}$). For more information on $V_{on(RMS)}$ and $V_{off(RMS)}$, see [Section 7.4](#).

There is a one-to-one correspondence between

- the bits in the RAM bitmap and the LCD elements,
- the RAM columns and the segment outputs,
- the RAM rows and the backplane outputs.

The display RAM bit map, [Figure 16](#), shows row 0 to row 3 and column 0 to column 43. Row 0 to row 3 correspond with the backplane outputs BP0 to BP3. Column 0 to column 43 correspond with the segment outputs S0 to S43. In multiplexed LCD applications, the data of each row of the display RAM is time-multiplexed with the corresponding backplane (row 0 with BP0, row 1 with BP1, and so on).

7.9.1 Data pointer

The addressing mechanism for the display RAM is realized using the data pointer. This allows the loading of an individual display data byte, or a series of display data bytes, into any location of the display RAM. The sequence commences with the initialization of the data pointer by the load-data-pointer command (see [Table 17](#)).

Following this command, an arriving data byte is stored starting at the display RAM address indicated by the data pointer.

The data pointer is automatically incremented. That is, after each byte is stored, the contents of the data pointer are incremented by two.

When the address counter reaches the end of the RAM, it stops incrementing after the last byte is transmitted. Redundant bits of the last byte and subsequent bytes transmitted are discarded until the pointer is reset. To send new RAM data, the data pointer must be reset.

If an I²C-bus or SPI-bus data access is terminated early, then the state of the data pointer is unknown. The data pointer must then be rewritten before further RAM accesses.

7.9.2 RAM filling

The RAM is organized in four rows and 44 columns. The eight transmitted data bits are placed in two successive display RAM columns of four rows (see Figure 17). In order to fill the whole four RAM rows, 22 bytes need to be sent to the PCA8546. After the last byte sent, the data pointer must be reset before the next RAM content update. Additional data bytes sent and any data bits that spill over the RAM are discarded.

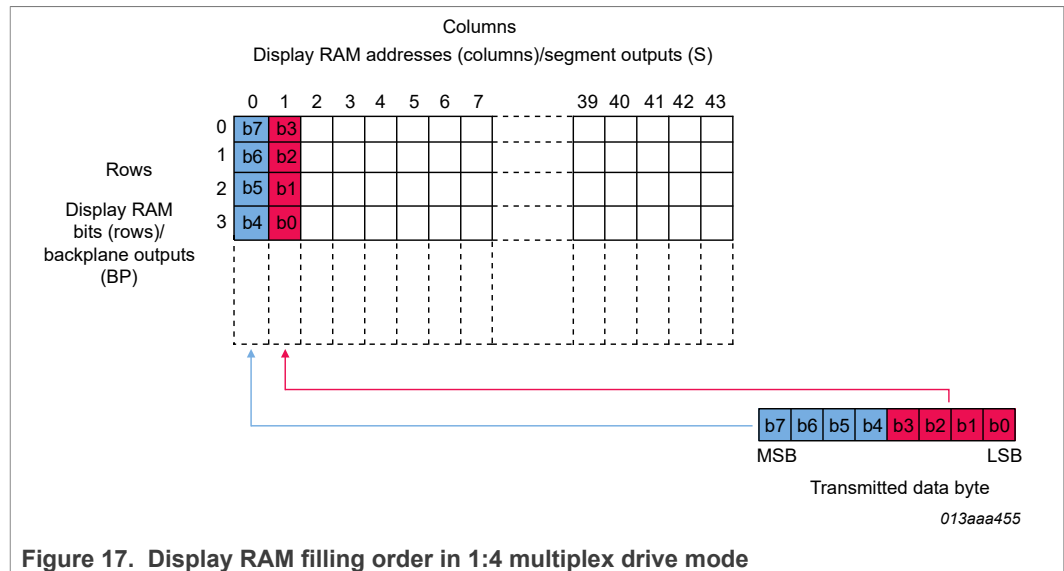
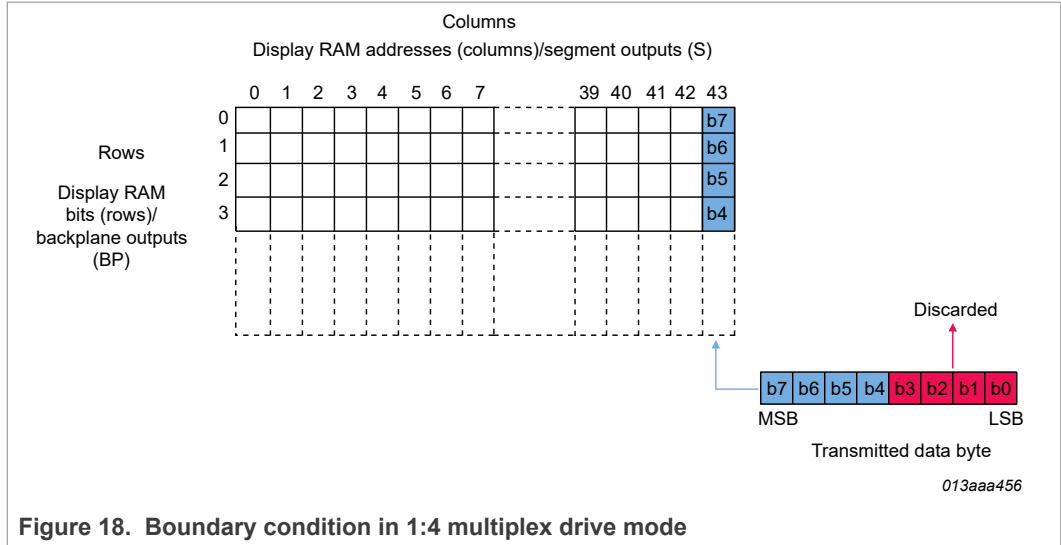

Figure 17. Display RAM filling order in 1:4 multiplex drive mode

Depending on the start address of the data pointer, there is the possibility for a boundary condition. This occurs when more data bits are sent than fit into the remaining RAM. The additional data bits are discarded. See Figure 18.



8 Bus interfaces

8.1 Control byte and register selection

After initiating the communication over the bus and sending the target address (I²C-bus, see [Section 8.2](#)) or subaddress (SPI-bus, see [Section 8.3](#)), a control byte follows. The purpose of this byte is to indicate both, the content for the following data bytes (RAM, or command) and to indicate that more control bytes will follow.

Typical sequences could be:

- target address/subaddress - control byte - command byte - command byte - command byte - end
- target address/subaddress - control byte - RAM byte - RAM byte - RAM byte - end
- target address/subaddress - control byte - command byte - control byte - RAM byte - end

In this way, it is possible to send a mixture of RAM and command data in one access or alternatively, to send just one type of data in one access.

Table 22. Control byte description

Bit	Symbol	Value	Description
7	CO		continue bit
		0	last control byte
		1	control bytes continue
6 to 5	RS[1:0]		register selection
		00	command register
		01	RAM data
		10, 11	unused
4 to 0	-	-	unused

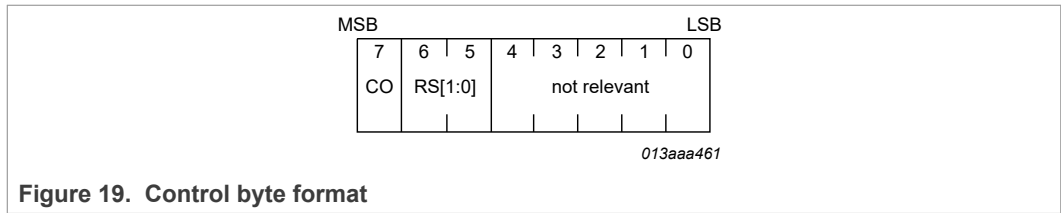

Figure 19. Control byte format

8.2 I²C-bus interface

The I²C-bus is for bidirectional, two-line communication between different ICs or modules. The two lines are a Serial DATA line (SDA) and a Serial CLOCK line (SCL). Both lines must be connected to a positive supply via a pull-up resistor when connected to the output stages of a device. Data transfer may be initiated only when the bus is not busy.

8.2.1 Bit transfer

One data bit is transferred during each clock pulse. The data on the SDA line must remain stable during the HIGH period of the clock pulse as changes in the data line at this time is interpreted as a control signal (see [Figure 20](#)).

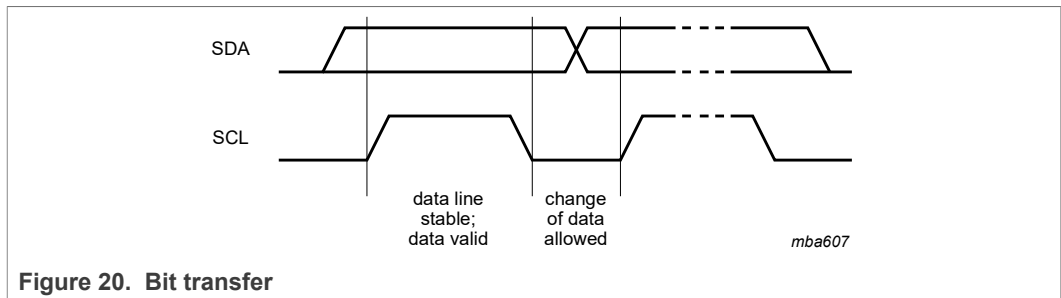

Figure 20. Bit transfer

8.2.2 START and STOP conditions

Both data and clock lines remain HIGH when the bus is not busy.

A HIGH-to-LOW change of the data line, while the clock is HIGH, is defined as the START condition (S).

A LOW-to-HIGH change of the data line, while the clock is HIGH, is defined as the STOP condition (P).

The START and STOP conditions are shown in [Figure 21](#).

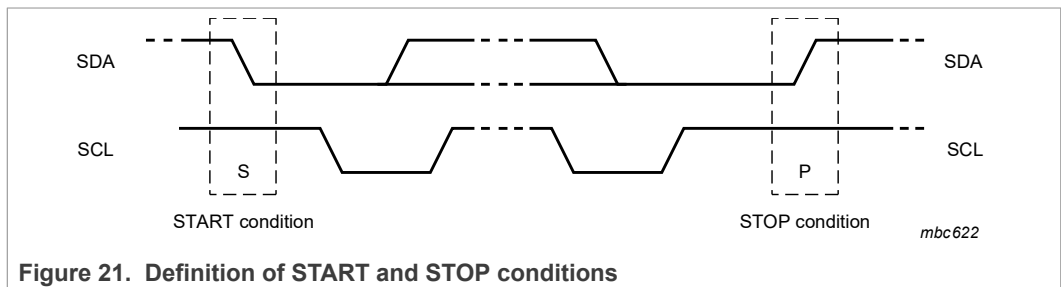
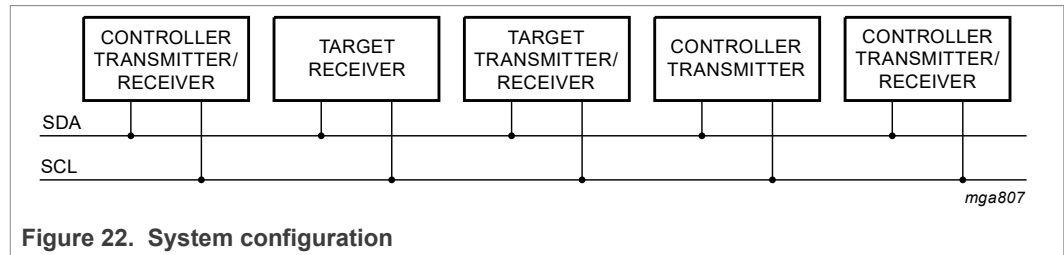

Figure 21. Definition of START and STOP conditions

8.2.3 System configuration

A device generating a message is a transmitter, a device receiving a message is the receiver. The device that controls the message is the controller and the devices which are controlled by the controller are the targets. The system configuration is shown in [Figure 22](#).



8.2.4 Acknowledge

The number of data bytes transferred between the START and STOP conditions from transmitter to receiver is unlimited. Each byte of 8 bits is followed by an acknowledge cycle.

- A target receiver which is addressed must generate an acknowledge after the reception of each byte.
- Also a controller receiver must generate an acknowledge after the reception of each byte that has been clocked out of the target transmitter.
- The device that acknowledges must pull-down the SDA line during the acknowledge clock pulse, so that the SDA line is stable LOW during the HIGH period of the acknowledge related clock pulse (set-up and hold times must be considered).
- A controller receiver must signal an end of data to the transmitter by not generating an acknowledge on the last byte that has been clocked out of the target. In this event, the transmitter must leave the data line HIGH to enable the controller to generate a STOP condition.

Acknowledgement on the I²C-bus is shown in [Figure 23](#).

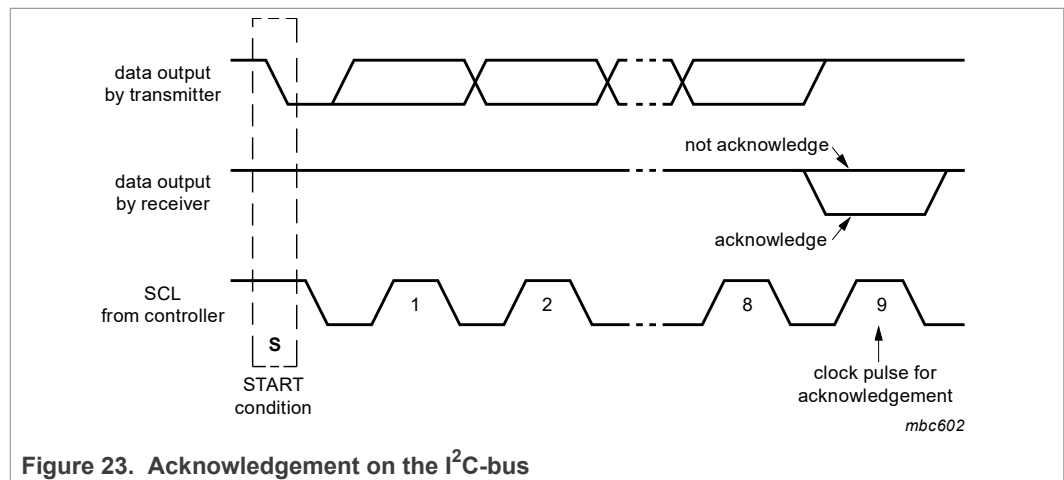

8.2.5 I²C-bus controller

The PCA8546 acts as an I²C-bus target receiver. It does not initiate I²C-bus transfers or transmit data to an I²C-bus controller receiver. Device selection depends on the I²C-bus target address.

8.2.6 Input filters

To enhance noise immunity in electrically adverse environments, RC low-pass filters are provided on the SDA and SCL lines.

8.2.7 I²C-bus target address

Device selection depends on the I²C-bus target address. Two different I²C-bus target addresses can be used to address the PCA8546 (see [Table 23](#)).

Table 23. I²C target address byte

	target address							
Bit	7	6	5	4	3	2	1	0
	MSB							LSB
	0	1	1	1	0	0	A0	R/W

The least significant bit of the target address byte is bit R/W (see [Table 24](#)).

Table 24. R/W-bit description

R/W	Description
0	write data
1	read data

Bit 1 of the target address is defined by connecting the input A0 to either V_{SS} (logic 0) or V_{DD} (logic 1). Therefore, two instances of PCA8546 can be distinguished on the same I²C-bus.

8.2.8 I²C-bus protocol

The I²C-bus protocol is shown in [Figure 24](#). The sequence is initiated with a START condition (S) from the I²C-bus controller which is followed by one of the two PCA8546 target addresses available. All PCA8546 with the corresponding A0 level acknowledge in parallel to the target address. But any PCA8546 with the alternative A0 level ignore the whole I²C-bus transfer.

After acknowledgement, a control byte follows (see [Section 8.1](#)).

The display bytes are stored in the display RAM at the address specified by the RAM data pointer.

The acknowledgement after each byte is made only by the addressed PCA8546. After the last data byte, the I²C-bus controller issues a STOP condition (P). Alternatively a START may be issued to RESTART an I²C-bus access.

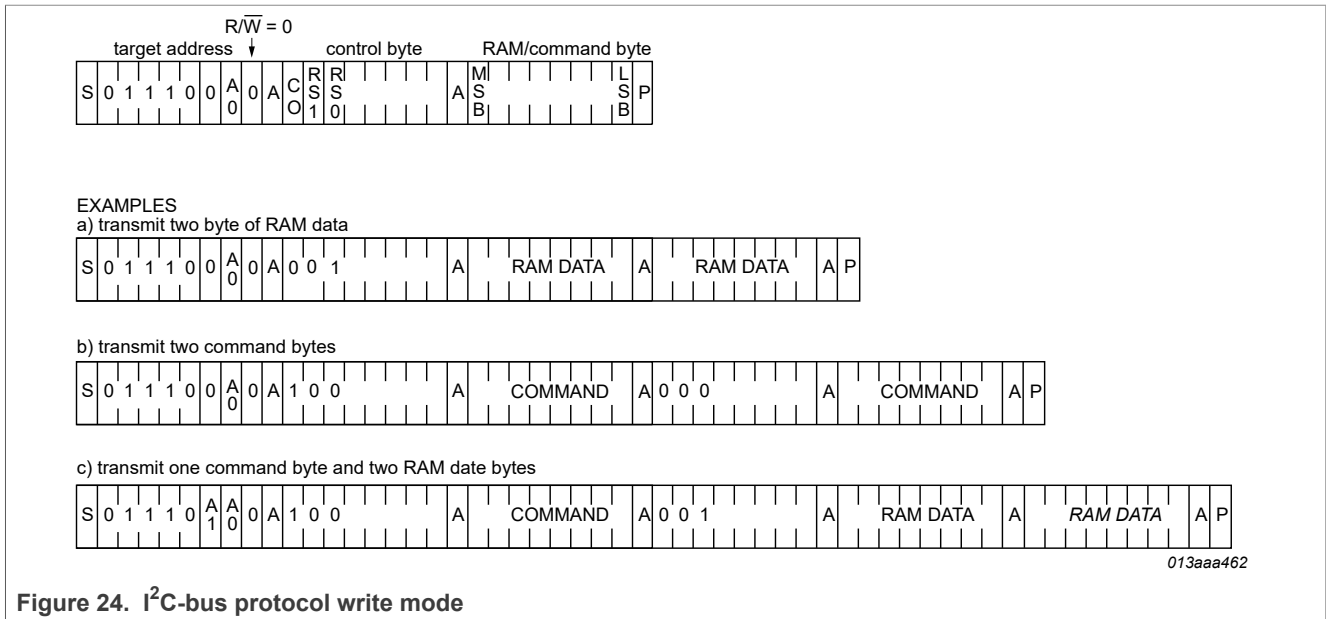

Figure 24. I²C-bus protocol write mode

8.2.8.1 Status read out

Status read out for I²C-bus operation only. This command initiates the read-out of a fixed value plus the target address bit A0 from the PCA8546. The read-out function allows the I²C controller to confirm the existence of the device on the I²C-bus.

Table 25. Status read out value

Bit	Symbol	Value	Description
7 to 1	-	0101 010	fixed value
0	A0	0	read back value is 0101 0100
		1	read back value is 0101 0101

If a readout is made, the R/\bar{W} bit must be logic 1 and then the next data byte following is provided by the PCA8546 as shown in Figure 25.

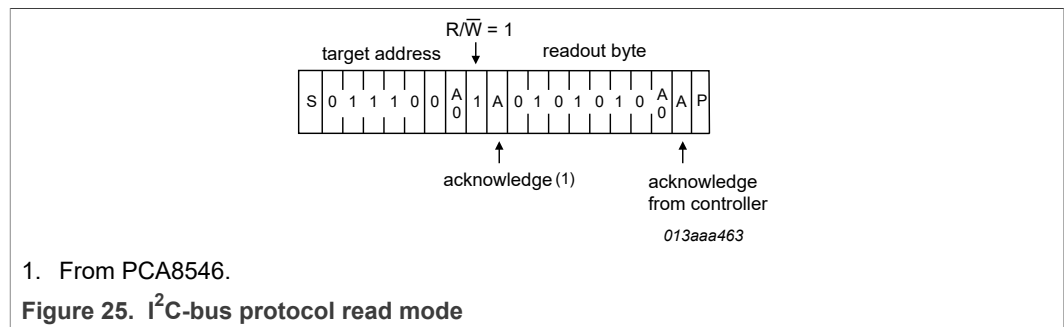

Figure 25. I²C-bus protocol read mode

In the unlikely case that the chip has entered the internal test mode, detection of this state is possible by using the modified status read-out detailed in Table 26. The read out value is modified to indicate that the chip has entered an internal test mode.

Table 26. Modified status read out value

Bit	Symbol	Value	Description
7 to 1	-	1111 000	fixed value
0	A0	0	read back value is 1111 0000
		1	read back value is 1111 0001

EMC detection

The PCA8546 is ruggedized against EMC susceptibility; however it is not possible to cover all cases. To detect if a severe EMC event has occurred, it is possible to check the responsiveness of the device by reading its register.

8.3 SPI-bus interface

Data transfer to the device is made via a 3 line SPI-bus (see Table 27). There is no output data line. The SPI-bus is initialized whenever the chip enable line pin \overline{CE} is inactive.

Table 27. Serial interface

Symbol	Function	Description
\overline{CE}	chip enable input ^[1] ; active LOW	when HIGH, the interface is reset
SCL	serial clock input	input may be higher than V_{DD}
SDI	serial data input	input may be higher than V_{DD} ; input data is sampled on the rising edge of SCL

[1] The chip enable must not be wired permanently LOW.

8.3.1 Data transmission

The chip enable signal is used to identify the transmitted data. Each data transfer is a byte with the Most Significant Bit (MSB) sent first.

The transmission is controlled by the active LOW chip enable signal \overline{CE} . The first byte transmitted is the subaddress byte.

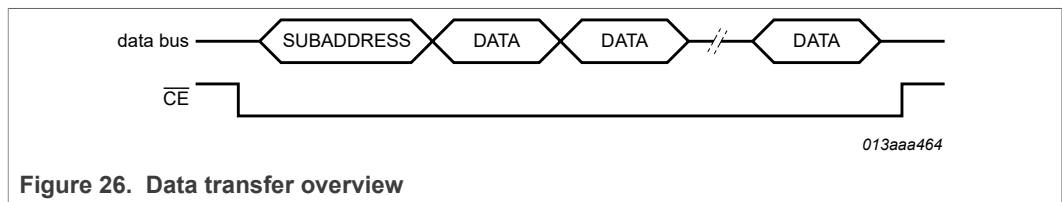

Figure 26. Data transfer overview

The subaddress byte opens the communication with a read/write bit and a subaddress. The subaddress is used to identify multiple devices on one SPI-bus.

Table 28. Subaddress byte definition

Bit	Symbol	Value	Description
7	R/ \overline{W}		data read or write selection
		0	write data
		1	read data

Table 28. Subaddress byte definition...continued

Bit	Symbol	Value	Description
6 to 5	SA[1:0]	01	subaddress ; other codes cause the device to ignore data transfer
4 to 0	-		unused

After the subaddress byte, a control byte follows (see [Section 8.1](#)).

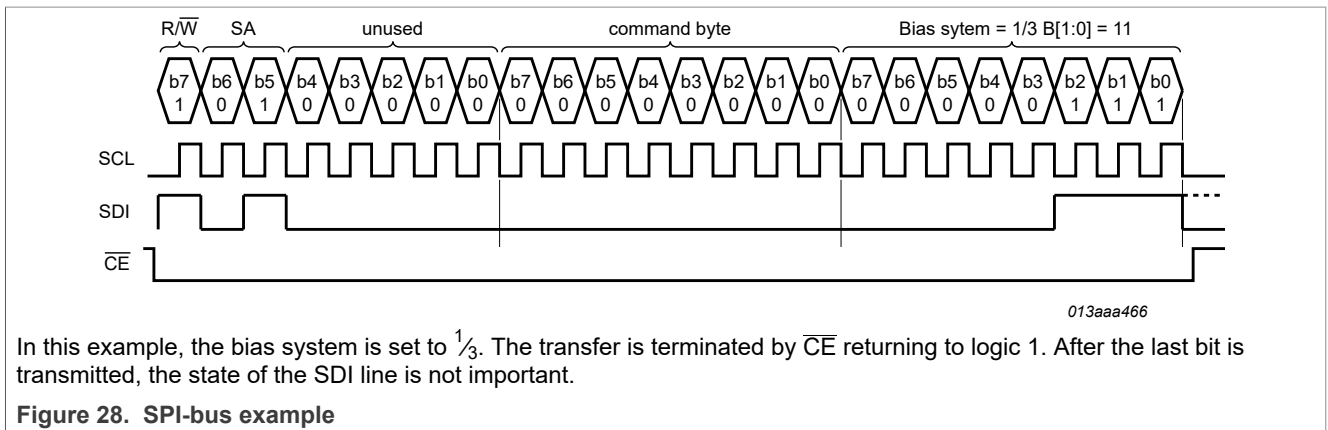
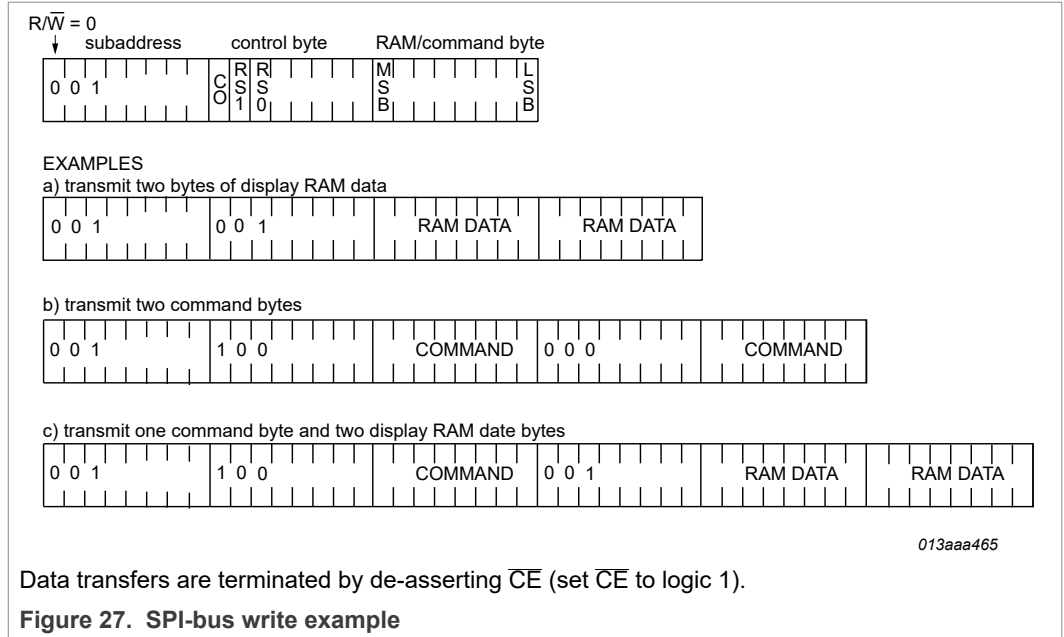

9 Internal circuitry

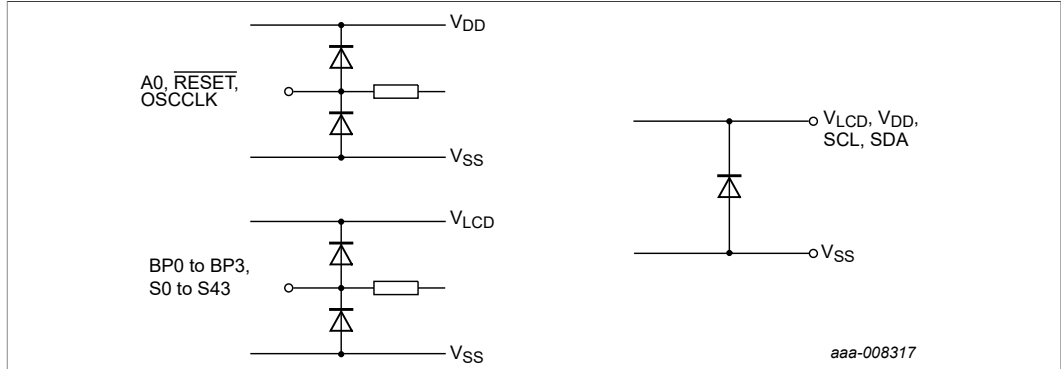

Figure 29. Device protection diagram for PCA8546A

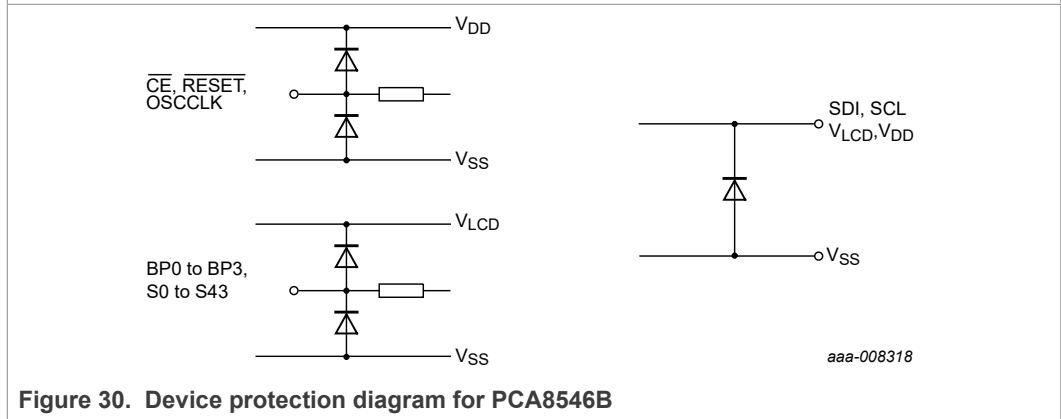



Figure 30. Device protection diagram for PCA8546B

10 Safety notes

CAUTION



This device is sensitive to ElectroStatic Discharge (ESD). Observe precautions for handling electrostatic sensitive devices. Such precautions are described in the *ANSI/ESD S20.20*, *IEC/ST 61340-5*, *JESD625-A* or equivalent standards.

CAUTION



Static voltages across the liquid crystal display can build up when the LCD supply voltage (V_{LCD}) is on while the IC supply voltage (V_{DD}) is off, or vice versa. This may cause unwanted display artifacts. To avoid such artifacts, V_{LCD} and V_{DD} must be applied or removed together.

11 Limiting values

Table 29. Limiting values

In accordance with the Absolute Maximum Rating System (IEC 60134).

Symbol	Parameter	Conditions	Min	Max	Unit
V _{DD}	supply voltage		-0.5	+6.5	V
I _{DD}	supply current		-50	+50	mA
V _{LCD}	LCD supply voltage		-0.5	+10	V
I _{DD(LCD)}	LCD supply current		-50	+50	mA
V _I	input voltage	PCA8546ATT			
		on pins SDA, OSCCLK, SCL, A0, RESET	-0.5	+6.5	V
		PCA8546BTT			
		on pins \overline{CE} , OSCCLK, SCL, SDI, RESET	-0.5	+6.5	V
I _I	input current		-10	+10	mA
V _O	output voltage	on pins S0 to S43, BP0 to BP3	-0.5	+10	V
		on pin SDA	-0.5	+6.5	V
I _O	output current		-10	+10	mA
I _{SS}	ground supply current		-50	+50	mA
P _{tot}	total power dissipation		-	400	mW
P/out	power dissipation per output		-	100	mW
V _{ESD}	electrostatic discharge voltage	HBM	[1] -	±3 500	V
		CDM	[2] -	±1 250	V
I _{Iu}	latch-up current		[3] -	200	mA
T _{stg}	storage temperature		[4] -65	+150	°C
T _{amb}	ambient temperature	operating device	-40	+95	°C

[1] Pass level; Human Body Model (HBM), according to [1].

[2] Pass level; Charge Device Model (CDM), according to [2].

[3] Pass level; latch-up testing according to [3] at maximum ambient temperature (T_{amb(max)}).

[4] According to the store and transport requirements (see [4]) the devices have to be stored at a temperature of +8 °C to +45 °C and a humidity of 25 % to 75 %.

12 Static characteristics

Table 30. Static characteristics

V_{DD} = 1.8 V to 5.5 V; V_{SS} = 0 V; V_{LCD} = 2.5 V to 9 V; T_{amb} = -40 °C to +95 °C; unless otherwise specified.

Symbol	Parameter	Conditions	Min	Typ	Max	Unit
Supplies						
V _{DD}	supply voltage		1.8	-	5.5	V

Table 30. Static characteristics...continued

$V_{DD} = 1.8 \text{ V to } 5.5 \text{ V}$; $V_{SS} = 0 \text{ V}$; $V_{LCD} = 2.5 \text{ V to } 9 \text{ V}$; $T_{amb} = -40 \text{ }^\circ\text{C to } +95 \text{ }^\circ\text{C}$; unless otherwise specified.

Symbol	Parameter	Conditions	Min	Typ	Max	Unit
V_{LCD}	LCD supply voltage	$V_{LCD} \geq V_{DD}$	2.5	-	9	V
$I_{DD(pd)}$	power-down mode supply current		[1] -	0.5	2	μA
I_{DD}	supply current	see Figure 31				
		external 9.6 kHz clock	[2] -	10	25	μA
		internal oscillator	[2] -	30	60	μA
$I_{DD(LCD)}$	LCD supply current	power-down, see Figure 32	[1][3] -	7	15	μA
		display active, see Figure 33	[4] -	55	140	μA
Logic						
V_I	input voltage		$V_{SS} - 0.5$	-	$V_{DD} + 0.5$	V
V_{IL}	LOW-level input voltage	on pins OSCCLK, A0 and RESET	-	-	$0.3V_{DD}$	V
V_{IH}	HIGH-level input voltage	on pins OSCCLK, A0 and RESET	$0.7V_{DD}$	-	-	V
V_O	output voltage		-0.5	-	$V_{DD} + 0.5$	V
V_{OH}	HIGH-level output voltage	driving load of 50 μA on pins OSCCLK	$0.8V_{DD}$	-	-	V
V_{OL}	LOW-level output voltage	driving load of 50 μA on pins OSCCLK	-	-	$0.2V_{DD}$	V
I_{OH}	HIGH-level output current	output source current; $V_{OH} = V_{DD} - 0.4 \text{ V}$				
		on pin OSCCLK				
		$V_{DD} = 1.8 \text{ V}$	0.7	1.6	-	mA
	$V_{DD} \geq 3.3 \text{ V}$	1.5	4.0	-	mA	
I_{OL}	LOW-level output current	output sink current; $V_{OL} = 0.4 \text{ V}$				
		on pin OSCCLK				
		$V_{DD} = 1.8 \text{ V}$	3	4	-	mA
	$V_{DD} \geq 3.3 \text{ V}$	5	10	-	mA	
I_L	leakage current	$V_i = V_{DD}$ or V_{SS} ; on pin OSCCLK	-1	-	+1	μA
I²C-bus^[5]						
On pins SCL and SDA						
V_I	input voltage		$V_{SS} - 0.5$	-	5.5	V
V_{IL}	LOW-level input voltage		-	-	$0.3V_{DD}$	V
V_{IH}	HIGH-level input voltage		$0.7V_{DD}$	-	-	V
V_O	output voltage		-0.5	-	+5.5	V

Table 30. Static characteristics...continued

$V_{DD} = 1.8\text{ V to }5.5\text{ V}$; $V_{SS} = 0\text{ V}$; $V_{LCD} = 2.5\text{ V to }9\text{ V}$; $T_{amb} = -40\text{ }^{\circ}\text{C to }+95\text{ }^{\circ}\text{C}$; unless otherwise specified.

Symbol	Parameter	Conditions	Min	Typ	Max	Unit	
I_L	leakage current	$V_I = V_{DD}$ or V_{SS}	-1	-	+1	μA	
On pin SDA							
I_{OL}	LOW-level output current	output sink current					
		$V_{DD} = 1.8\text{ V}$	3	5.5	-	mA	
		$V_{DD} = 3.3\text{ V}$	5	9	-	mA	
SPI-bus							
V_I	input voltage	on pin SCL	$V_{SS} - 0.5$	-	5.5	V	
		on pins $\overline{\text{CE}}$ and SDI	$V_{SS} - 0.5$	-	$V_{DD} + 0.5$	V	
On pins SCL, $\overline{\text{CE}}$ and SDI							
V_{IL}	LOW-level input voltage		-	-	$0.3V_{DD}$	V	
V_{IH}	HIGH-level input voltage		$0.7V_{DD}$	-	-	V	
I_L	leakage current	$V_I = V_{DD}$ or V_{SS}	-1	-	+1	μA	
LCD outputs							
ΔV_O	output voltage variation	on pins BP0 to BP3	[6]	-	2.5	+10	mV
		on pins S0 to S43	[7]	-	2.5	+10	mV
R_O	output resistance	$V_{LCD} = 7\text{ V}$; on pins BP0 to BP3	[8]	-	0.9	5.0	$\text{k}\Omega$
		$V_{LCD} = 7\text{ V}$; on pins S0 to S43	[8]	-	1.5	6.0	$\text{k}\Omega$

[1] Power-down mode is enabled; I²C-bus or SPI-bus inactive.

[2] 1/4 bias; display enabled; LCD outputs are open circuit; RAM is all written with logic 1; inputs at V_{SS} or V_{DD} ; default display prescale factor; I²C-bus or SPI-bus inactive.

[3] Strongly linked to V_{LCD} voltage. See Figure 32.

[4] 1/4 bias; display enabled; LCD outputs are open circuit; RAM is all written with logic 1; default display prescale factor.

[5] The I²C-bus interface of PCA8546 is 5 V tolerant.

[6] Variation between any two backplanes on a given voltage level; static measured.

[7] Variation between any two segments on a given voltage level; static measured.

[8] Outputs measured one at a time.

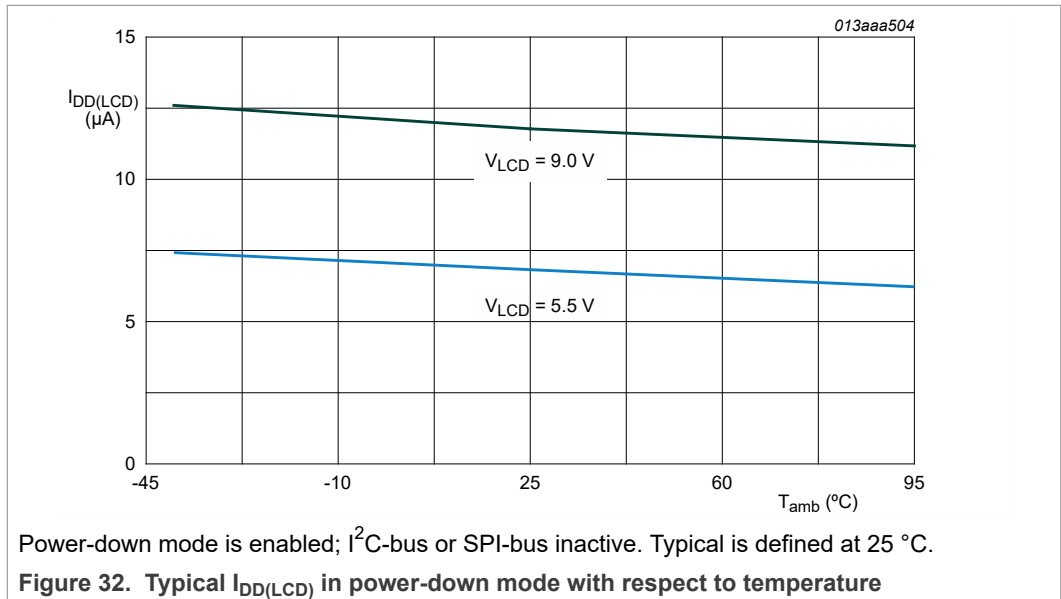
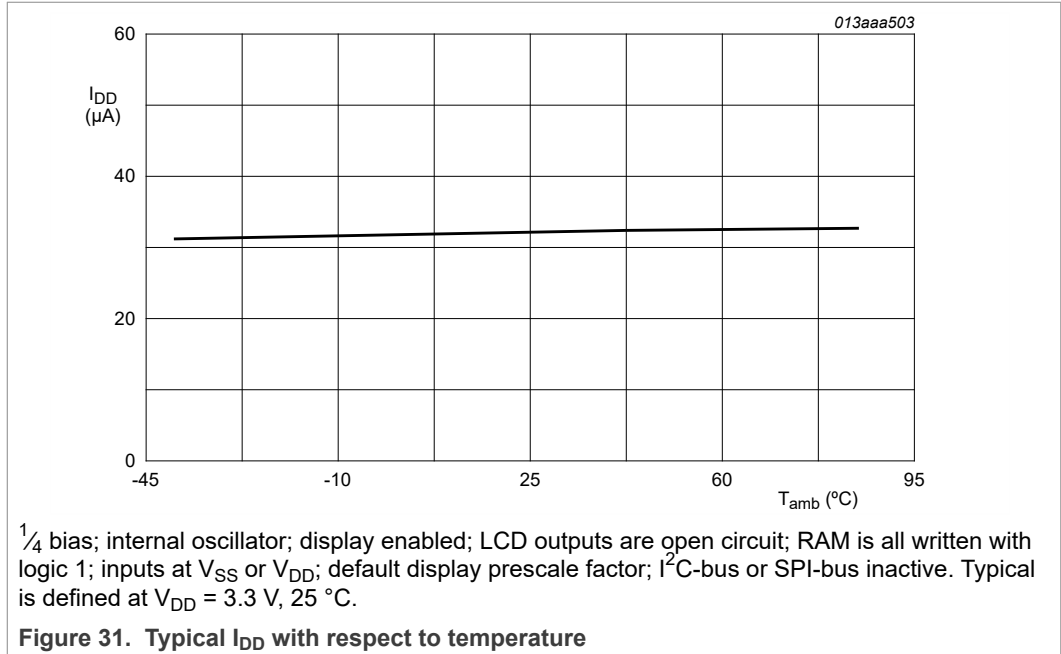

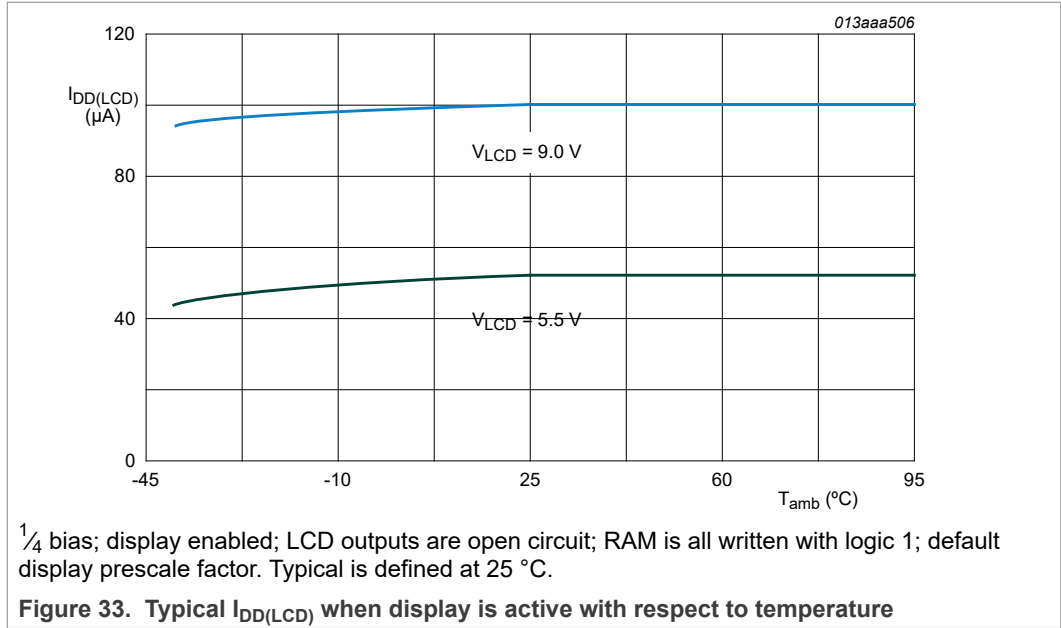

13 Dynamic characteristics

Table 31. Dynamic characteristics

$V_{DD} = 1.8\text{ V to }5.5\text{ V}$; $V_{SS} = 0\text{ V}$; $V_{LCD} = 2.5\text{ V to }9\text{ V}$; $T_{amb} = -40\text{ °C to }+95\text{ °C}$; unless otherwise specified.

Symbol	Parameter	Conditions	Min	Typ	Max	Unit
f_{clk}	clock frequency	output on pin OSCCLK; $V_{DD} = 3.3\text{ V}$	[1] 7 800	9 600	11 040	Hz
$f_{clk(ext)}$	external clock frequency	EFR = 0	-	-	250 000	Hz
$t_{(RESET_N)}$	RESET_N pulse width	LOW time	400	-	-	ns
External clock source used on pin OSCCLK						
$t_{clk(H)}$	clock HIGH time		33	-	-	µs
$t_{clk(L)}$	clock LOW time		33	-	-	µs

[1] Frequency present on OSCCLK with default display frequency division factor.

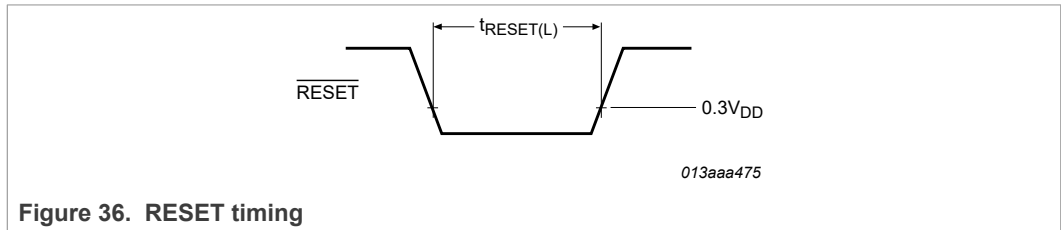
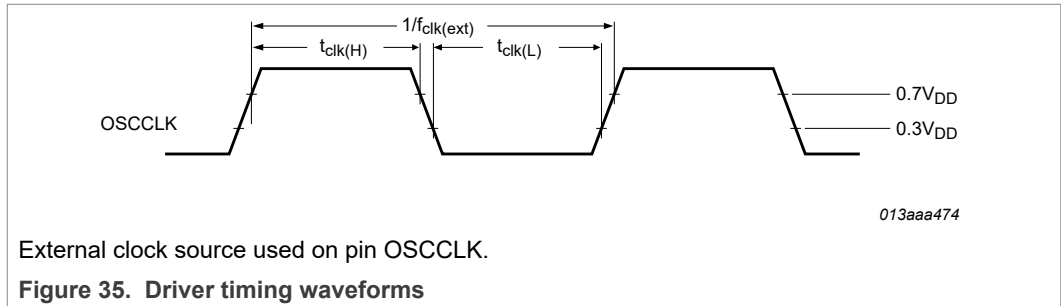
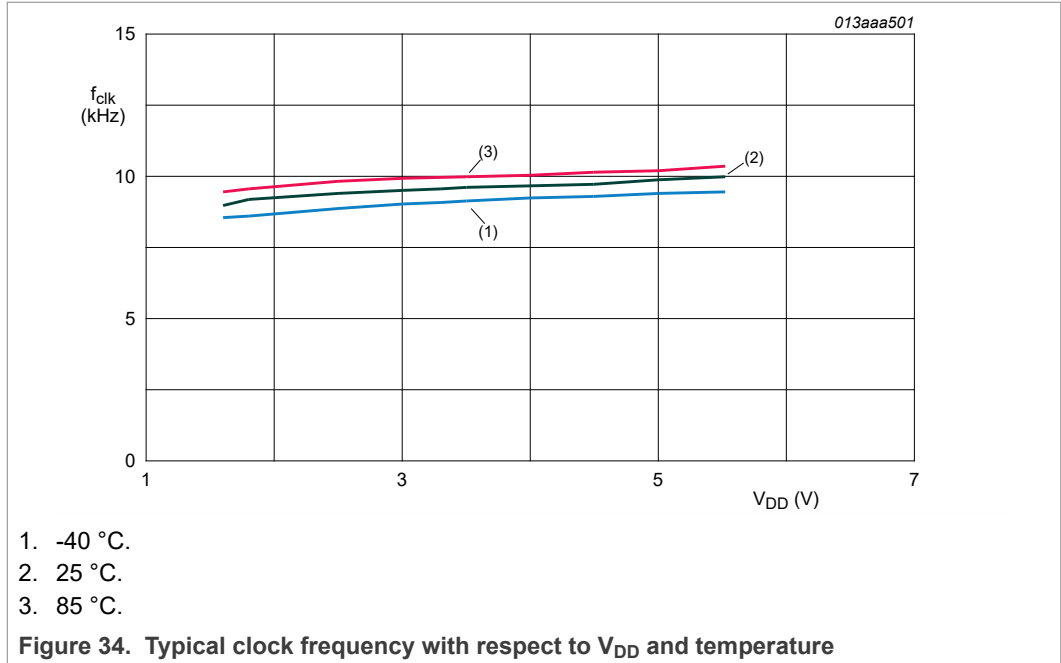

Table 32. Timing characteristics: I²C-bus

$V_{DD} = 1.8\text{ V to }5.5\text{ V}$; $V_{SS} = 0\text{ V}$; $T_{amb} = -40\text{ °C to }+95\text{ °C}$; unless otherwise specified. All timing values are valid within the operating supply voltage and temperature range and referenced to V_{IL} and V_{IH} with an input voltage swing of V_{SS} to V_{DD} . Timing waveforms see [Figure 37](#).

Symbol	Parameter	Conditions	Min	Typ	Max	Unit
Pin SCL						
f_{SCL}	SCL clock frequency		[1] -	-	400	kHz

Table 32. Timing characteristics: I²C-bus...continued

$V_{DD} = 1.8\text{ V to }5.5\text{ V}$; $V_{SS} = 0\text{ V}$; $T_{amb} = -40\text{ }^{\circ}\text{C to }+95\text{ }^{\circ}\text{C}$; unless otherwise specified. All timing values are valid within the operating supply voltage and temperature range and referenced to V_{IL} and V_{IH} with an input voltage swing of V_{SS} to V_{DD} . Timing waveforms see [Figure 37](#).

Symbol	Parameter	Conditions	Min	Typ	Max	Unit
t_{LOW}	LOW period of the SCL clock		1.3	-	-	μs
t_{HIGH}	HIGH period of the SCL clock		0.6	-	-	μs
Pin SDA						
$t_{SU,DAT}$	data set-up time		100	-	-	ns
$t_{HD,DAT}$	data hold time		0	-	-	ns
Pins SCL and SDA						
t_{BUF}	bus free time between a STOP and START condition		1.3	-	-	μs
$t_{SU,STO}$	set-up time for STOP condition		0.6	-	-	μs
$t_{HD,STA}$	hold time (repeated) START condition		0.6	-	-	μs
$t_{SU,STA}$	set-up time for a repeated START condition		0.6	-	-	μs
t_r	rise time of both SDA and SCL signals	$f_{SCL} = 400\text{ kHz}$	-	-	0.3	μs
		$f_{SCL} = 100\text{ kHz}$	-	-	1.0	μs
t_f	fall time of both SDA and SCL signals		-	-	0.3	μs
$t_{VD,ACK}$	data valid acknowledge time		[2] 0.6	-	-	μs
$t_{VD,DAT}$	data valid time		[3] 0.6	-	-	μs
C_b	capacitive load for each bus line		-	-	400	pF
t_{SP}	pulse width of spikes that must be suppressed by the input filter		[4] -	-	50	ns

[1] The minimum SCL clock frequency is limited by the bus time-out feature, which resets the serial bus interface if either the SDA or SCL is held LOW for a minimum of 25 ms. The bus time-out feature must be disabled for DC operation.

[2] $t_{VD,ACK}$ = time for acknowledgement signal from SCL LOW to SDA output LOW.

[3] $t_{VD,DAT}$ = minimum time for valid SDA output following SCL LOW.

[4] Input filters on the SDA and SCL inputs suppress noise spikes of less than 50 ns.

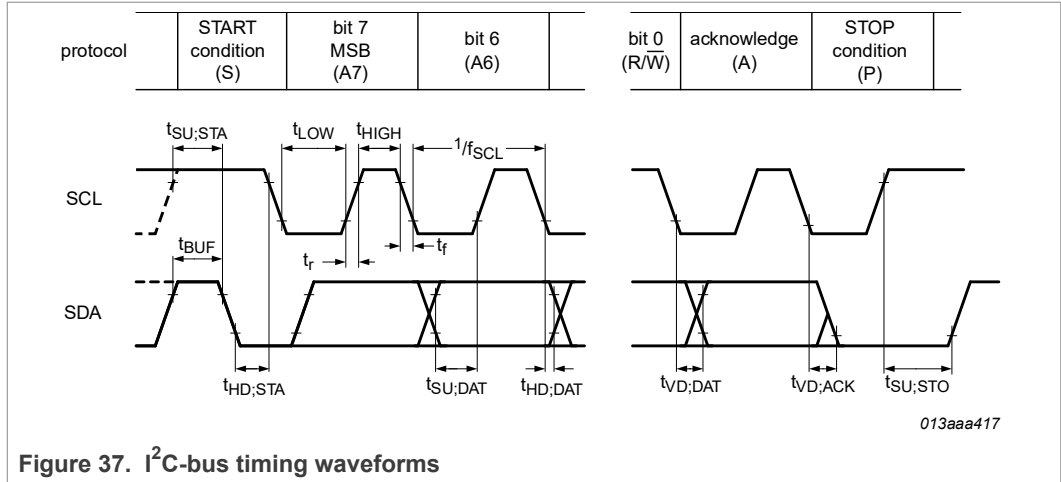

Figure 37. I²C-bus timing waveforms

Table 33. Timing characteristics: SPI-bus

$V_{DD} = 1.8\text{ V to }5.5\text{ V}$; $V_{SS} = 0\text{ V}$; $T_{amb} = -40\text{ }^{\circ}\text{C to }+95\text{ }^{\circ}\text{C}$. All timing values are valid within the operating supply voltage and temperature range and referenced to V_{IL} and V_{IH} with an input voltage swing of V_{SS} to V_{DD} . Timing waveforms see Figure 38.

Symbol	Parameter	Conditions	$V_{DD} < 2.7\text{ V}$		$V_{DD} \geq 2.7\text{ V}$		Unit
			Min	Max	Min	Max	
$f_{clk(SCL)}$	SCL clock frequency		-	2	-	5	MHz
t_{SCL}	SCL time		500	-	200	-	ns
$t_{clk(H)}$	clock HIGH time		200	-	80	-	ns
$t_{clk(L)}$	clock LOW time		200	-	80	-	ns
t_r	rise time	for SCL signal	-	100	-	100	ns
t_f	fall time	for SCL signal	-	100	-	100	ns
$t_{su(CE_N)}$	CE_N set-up time		150	-	80	-	ns
$t_h(CE_N)$	CE_N hold time		0	-	0	-	ns
$t_{rec(CE_N)}$	CE_N recovery time		100	-	100	-	ns
t_{su}	set-up time	set-up time for SDI data	10	-	5	-	ns
t_h	hold time	hold time for SDI data	25	-	10	-	ns

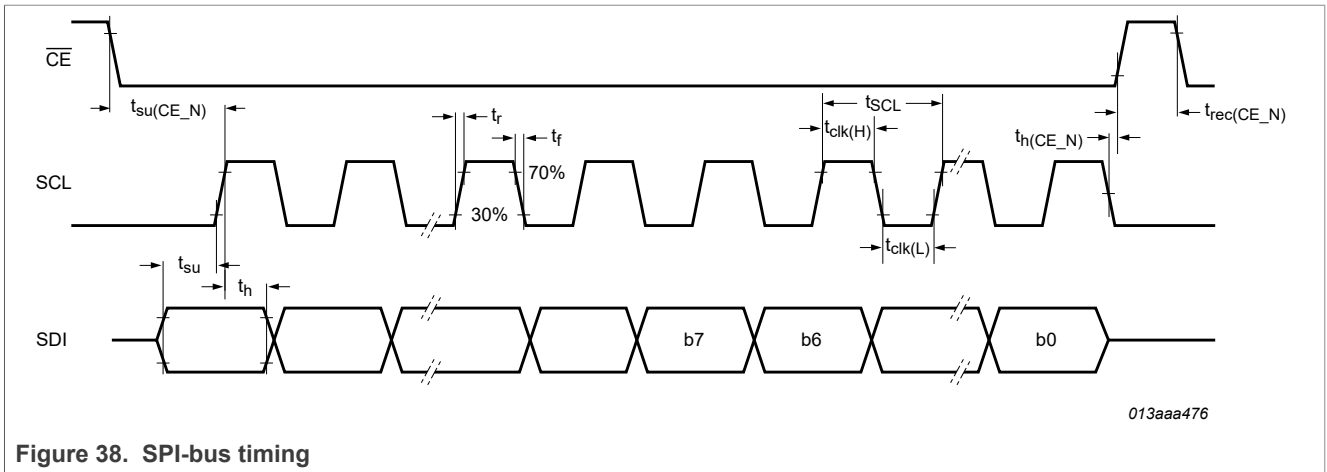
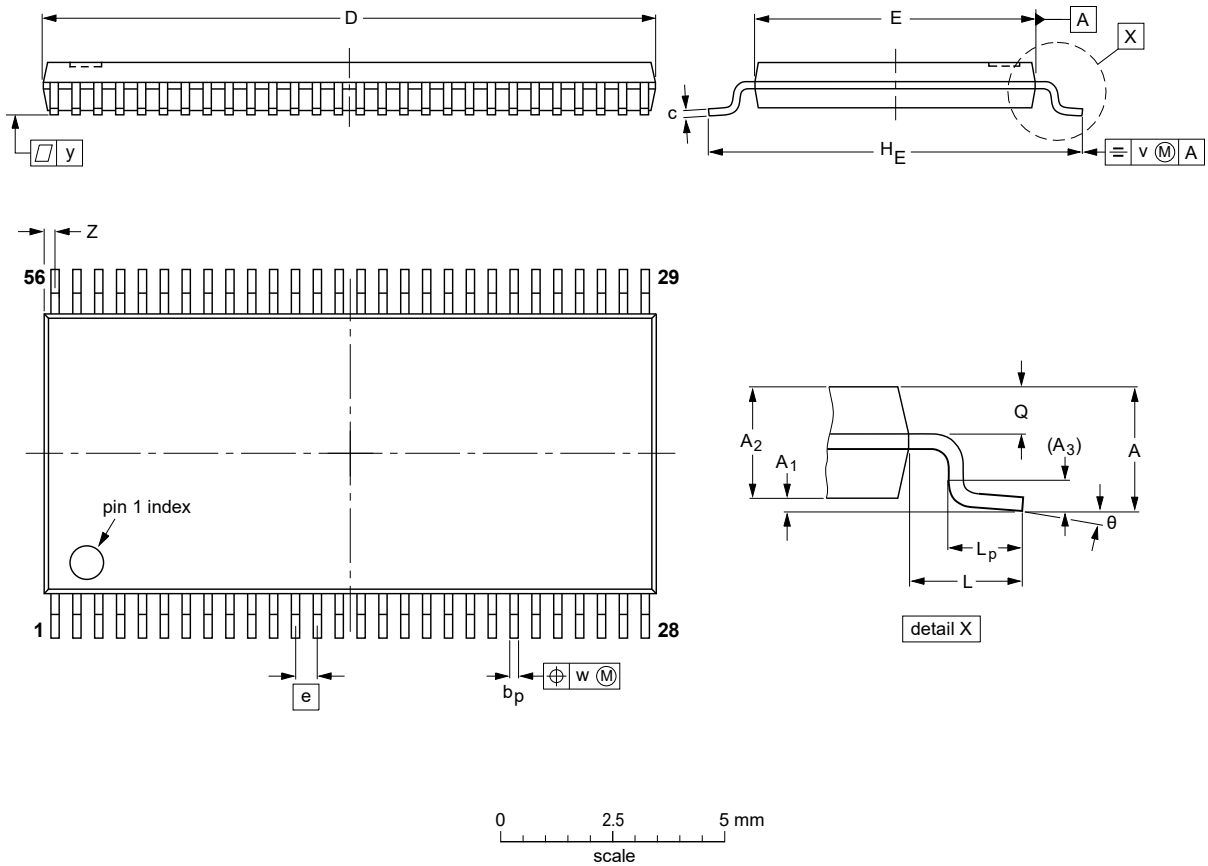

Figure 38. SPI-bus timing

14 Package outline

TSSOP56: plastic thin shrink small outline package; 56 leads; body width 6.1 mm

SOT364-1



DIMENSIONS (mm are the original dimensions).

UNIT	A max.	A ₁	A ₂	A ₃	b _p	c	D ⁽¹⁾	E ⁽²⁾	e	H _E	L	L _p	Q	v	w	y	Z	θ
mm	1.2	0.15 0.05	1.05 0.85	0.25	0.28 0.17	0.2 0.1	14.1 13.9	6.2 6.0	0.5	8.3 7.9	1	0.8 0.4	0.50 0.35	0.25	0.08	0.1	0.5 0.1	8° 0°

Notes

1. Plastic or metal protrusions of 0.15 mm maximum per side are not included.
2. Plastic interlead protrusions of 0.25 mm maximum per side are not included.

OUTLINE VERSION	REFERENCES				EUROPEAN PROJECTION	ISSUE DATE
	IEC	JEDEC	JEITA			
SOT364-1		MO-153				99-12-27 03-02-19

Figure 39. Package outline SOT364-1 (TSSOP56)

15 Handling information

All input and output pins are protected against ElectroStatic Discharge (ESD) under normal handling. When handling Metal-Oxide Semiconductor (MOS) devices ensure that all normal precautions are taken as described in *JESD625-A*, *IEC 61340-5* or equivalent standards.

16 Packing information

16.1 Tape and reel information

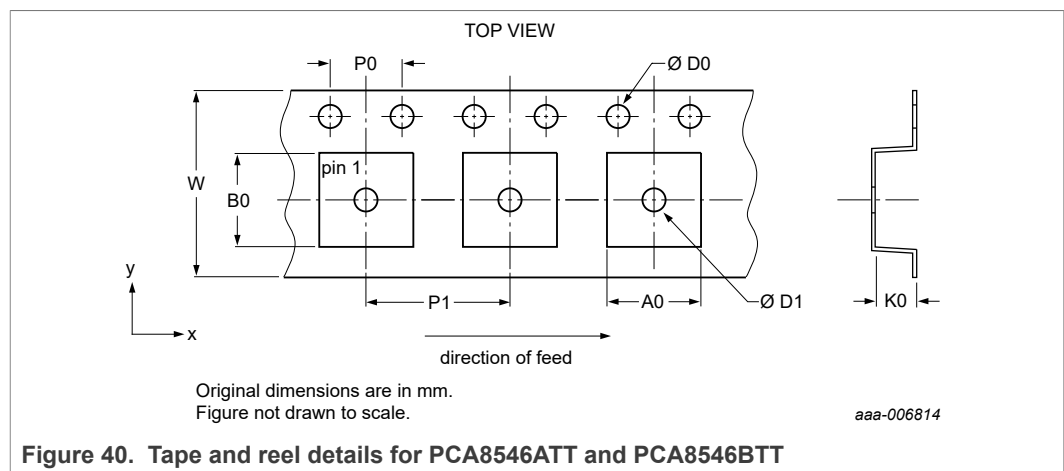

Table 34. Carrier tape dimensions of PCA8546ATT and PCA8546BTT

Symbol	Description	Value	Unit
Compartments			
A0	pocket width in x direction	8.65 to 8.9	mm
B0	pocket width in y direction	14.4 to 15.8	mm
K0	pocket depth	1.5 to 1.8	mm
P1	pocket hole pitch	12	mm
D1	pocket hole diameter	1.5 to 2.05	mm
Overall dimensions			
W	tape width	24	mm
D0	sprocket hole diameter	1.5 to 1.55	mm
P0	sprocket hole pitch	4	mm

17 Soldering of SMD packages

This text provides a very brief insight into a complex technology. A more in-depth account of soldering ICs can be found in Application Note AN10365 “Surface mount reflow soldering description”.

17.1 Introduction to soldering

Soldering is one of the most common methods through which packages are attached to Printed Circuit Boards (PCBs), to form electrical circuits. The soldered joint provides both the mechanical and the electrical connection. There is no single soldering method that is ideal for all IC packages. Wave soldering is often preferred when through-hole and Surface Mount Devices (SMDs) are mixed on one printed wiring board; however, it is not suitable for fine pitch SMDs. Reflow soldering is ideal for the small pitches and high densities that come with increased miniaturization.

17.2 Wave and reflow soldering

Wave soldering is a joining technology in which the joints are made by solder coming from a standing wave of liquid solder. The wave soldering process is suitable for the following:

- Through-hole components
- Leaded or leadless SMDs, which are glued to the surface of the printed circuit board

Not all SMDs can be wave soldered. Packages with solder balls, and some leadless packages which have solder lands underneath the body, cannot be wave soldered. Also, leaded SMDs with leads having a pitch smaller than ~0.6 mm cannot be wave soldered, due to an increased probability of bridging.

The reflow soldering process involves applying solder paste to a board, followed by component placement and exposure to a temperature profile. Leaded packages, packages with solder balls, and leadless packages are all reflow solderable.

Key characteristics in both wave and reflow soldering are:

- Board specifications, including the board finish, solder masks and vias
- Package footprints, including solder thieves and orientation
- The moisture sensitivity level of the packages
- Package placement
- Inspection and repair
- Lead-free soldering versus SnPb soldering

17.3 Wave soldering

Key characteristics in wave soldering are:

- Process issues, such as application of adhesive and flux, clinching of leads, board transport, the solder wave parameters, and the time during which components are exposed to the wave
- Solder bath specifications, including temperature and impurities

17.4 Reflow soldering

Key characteristics in reflow soldering are:

- Lead-free versus SnPb soldering; note that a lead-free reflow process usually leads to higher minimum peak temperatures (see [Figure 41](#)) than a SnPb process, thus reducing the process window
- Solder paste printing issues including smearing, release, and adjusting the process window for a mix of large and small components on one board

- Reflow temperature profile; this profile includes preheat, reflow (in which the board is heated to the peak temperature) and cooling down. It is imperative that the peak temperature is high enough for the solder to make reliable solder joints (a solder paste characteristic). In addition, the peak temperature must be low enough that the packages and/or boards are not damaged. The peak temperature of the package depends on package thickness and volume and is classified in accordance with [Table 35](#) and [Table 36](#)

Table 35. SnPb eutectic process (from J-STD-020D)

Package thickness (mm)	Package reflow temperature (°C)	
	Volume (mm ³)	
	< 350	≥ 350
< 2.5	235	220
≥ 2.5	220	220

Table 36. Lead-free process (from J-STD-020D)

Package thickness (mm)	Package reflow temperature (°C)		
	Volume (mm ³)		
	< 350	350 to 2000	> 2000
< 1.6	260	260	260
1.6 to 2.5	260	250	245
> 2.5	250	245	245

Moisture sensitivity precautions, as indicated on the packing, must be respected at all times.

Studies have shown that small packages reach higher temperatures during reflow soldering, see [Figure 41](#).

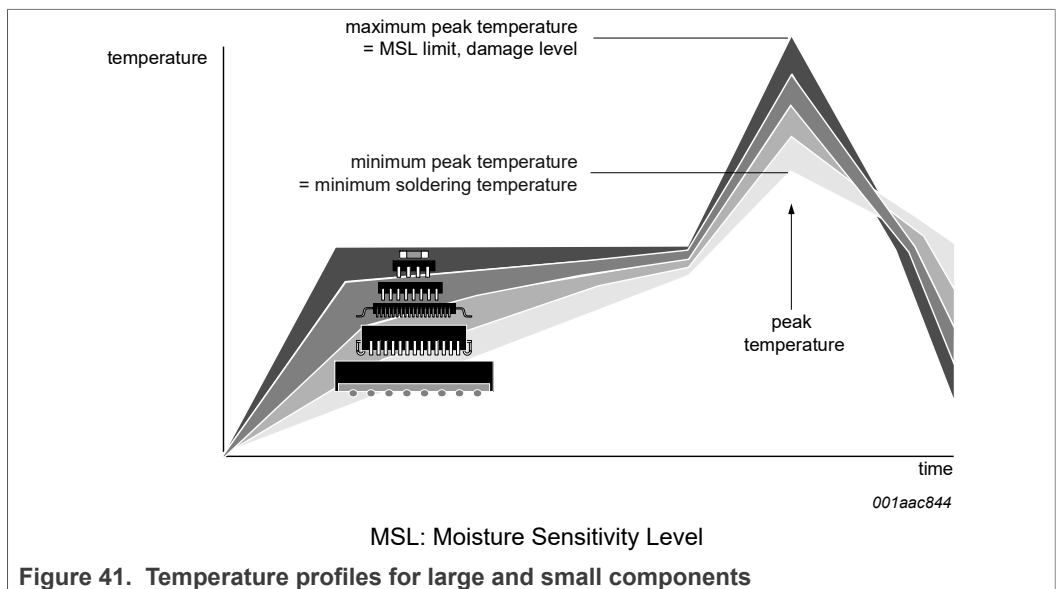

Figure 41. Temperature profiles for large and small components

For further information on temperature profiles, refer to Application Note *AN10365*
“Surface mount reflow soldering description”.

18 Footprint information for reflow soldering

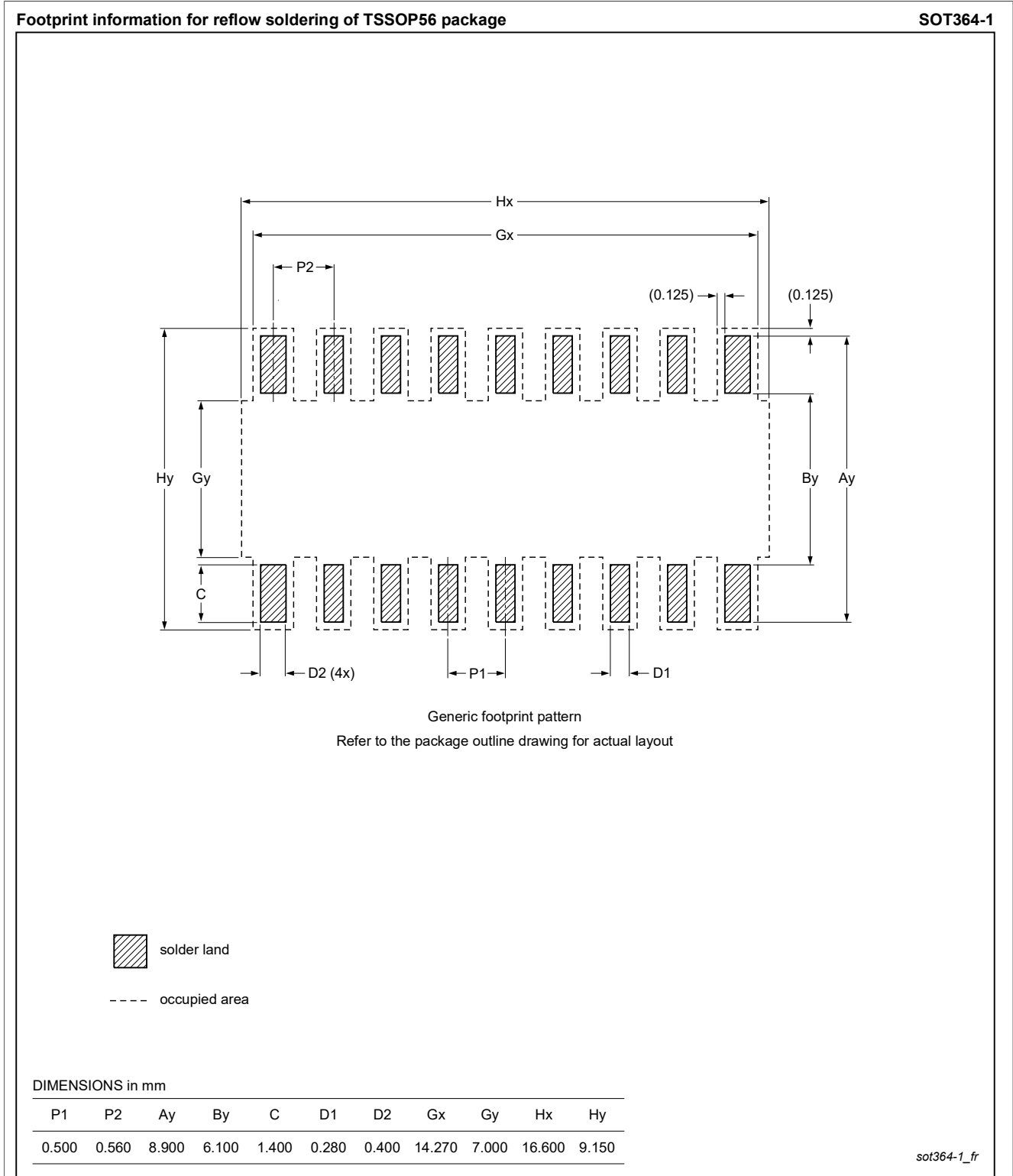

Figure 42. Footprint information for reflow soldering of SOT364-1 (TSSOP56) package

19 Appendix

19.1 LCD segment driver selection

Table 37. Selection of LCD segment drivers

Type name	Number of elements at MUX							V _{DD} (V)	V _{LCD} (V)	f _{fr} (Hz)	V _{LCD} (V) charge pump	V _{LCD} (V) temperature compensat.	T _{amb} (°C)	Interface	Package	AEC- Q100
	1:1	1:2	1:3	1:4	1:6	1:8	1:9									
PCA8561AHN ^[1]	18	36	54	72	-	-	-	1.8 to 5.5	1.8 to 5.5	32 to 256 ^[2]	N	N	-40 to 105	I ² C	HVQFN32	Y
PCA8561BHN ^[1]	18	36	54	72	-	-	-	1.8 to 5.5	1.8 to 5.5	32 to 256 ^[2]	N	N	-40 to 105	SPI	HVQFN32	Y
PCF8566TS	24	48	72	96	-	-	-	2.5 to 6	2.5 to 6	69	N	N	-40 to 85	I ² C	VSO40	N
PCF85162T	32	64	96	128	-	-	-	1.8 to 5.5	2.5 to 6.5	82	N	N	-40 to 85	I ² C	TSSOP48	N
PCA85162T	32	64	96	128	-	-	-	1.8 to 5.5	2.5 to 8	110	N	N	-40 to 95	I ² C	TSSOP48	Y
PCA85262ATT	32	64	96	128	-	-	-	1.8 to 5.5	2.5 to 8	200	N	N	-40 to 105	I ² C	TSSOP48	Y
PCF8551ATT ^[1]	36	72	108	144	-	-	-	1.8 to 5.5	1.8 to 5.5	32 to 128 ^[2]	N	N	-40 to 85	I ² C	TSSOP48	N
PCF8551BTT ^[1]	36	72	108	144	-	-	-	1.8 to 5.5	1.8 to 5.5	32 to 128 ^[2]	N	N	-40 to 85	SPI	TSSOP48	N
PCA8551ATT ^[1]	36	72	108	144	-	-	-	1.8 to 5.5	1.8 to 5.5	32 to 256 ^[2]	N	N	-40 to 105	I ² C	TSSOP48	Y
PCA8551BTT ^[1]	36	72	108	144	-	-	-	1.8 to 5.5	1.8 to 5.5	32 to 256 ^[2]	N	N	-40 to 105	SPI	TSSOP48	Y
PCF85176T	40	80	120	160	-	-	-	1.8 to 5.5	2.5 to 6.5	82	N	N	-40 to 85	I ² C	TSSOP56	N
PCA85176T	40	80	120	160	-	-	-	1.8 to 5.5	2.5 to 8	110	N	N	-40 to 95	I ² C	TSSOP56	Y
PCA85276ATT	40	80	120	160	-	-	-	1.8 to 5.5	2.5 to 8	200	N	N	-40 to 105	I ² C	TSSOP56	Y
PCF85176H	40	80	120	160	-	-	-	1.8 to 5.5	2.5 to 6.5	82	N	N	-40 to 85	I ² C	TQFP64	N
PCA85176H	40	80	120	160	-	-	-	1.8 to 5.5	2.5 to 8	82	N	N	-40 to 95	I ² C	TQFP64	Y
PCF8553ATT ^[1]	40	80	120	160	-	-	-	1.8 to 5.5	1.8 to 5.5	32 to 128 ^[2]	N	N	-40 to 85	I ² C	TSSOP56	N
PCF8553BTT ^[1]	40	80	120	160	-	-	-	1.8 to 5.5	1.8 to 5.5	32 to 128 ^[2]	N	N	-40 to 85	SPI	TSSOP56	N
PCA8553ATT ^[1]	40	80	120	160	-	-	-	1.8 to 5.5	1.8 to 5.5	32 to 256 ^[2]	N	N	-40 to 105	I ² C	TSSOP56	Y
PCA8553BTT ^[1]	40	80	120	160	-	-	-	1.8 to 5.5	1.8 to 5.5	32 to 256 ^[2]	N	N	-40 to 105	SPI	TSSOP56	Y
PCA8546ATT ^[1]	-	-	-	176	-	-	-	1.8 to 5.5	2.5 to 9	60 to 300 ^[2]	N	N	-40 to 95	I ² C	TSSOP56	Y
PCA8546BTT ^[1]	-	-	-	176	-	-	-	1.8 to 5.5	2.5 to 9	60 to 300 ^[2]	N	N	-40 to 95	SPI	TSSOP56	Y
PCA8547AHT ^[1]	44	88	-	176	-	-	-	1.8 to 5.5	2.5 to 9	60 to 300 ^[2]	Y	Y ^[3]	-40 to 95	I ² C	TQFP64	Y
PCA8547BHT ^[1]	44	88	-	176	-	-	-	1.8 to 5.5	2.5 to 9	60 to 300 ^[2]	Y	Y ^[3]	-40 to 95	SPI	TQFP64	Y
PCF85134HL	60	120	180	240	-	-	-	1.8 to 5.5	2.5 to 6.5	82	N	N	-40 to 85	I ² C	LQFP80	N

Table 37. Selection of LCD segment drivers...continued

Type name	Number of elements at MUX							V _{DD} (V)	V _{LCD} (V)	f _{fr} (Hz)	V _{LCD} (V) charge pump	V _{LCD} (V) temperature compensat.	T _{amb} (°C)	Interface	Package	AEC- Q100
	1:1	1:2	1:3	1:4	1:6	1:8	1:9									
PCA85134H	60	120	180	240	-	-	-	1.8 to 5.5	2.5 to 8	82	N	N	-40 to 95	I ² C	LQFP80	Y
PCA8543AHL	60	120	-	240	-	-	-	2.5 to 5.5	2.5 to 9	60 to 300 ^[2]	Y	Y	-40 to 105	I ² C	LQFP80	Y
PCF8545ATT ^[1]	-	-	-	176	252	320	-	1.8 to 5.5	2.5 to 5.5	60 to 300 ^[2]	N	N	-40 to 85	I ² C	TSSOP56	N
PCF8545BTT ^[1]	-	-	-	176	252	320	-	1.8 to 5.5	2.5 to 5.5	60 to 300 ^[2]	N	N	-40 to 85	SPI	TSSOP56	N
PCF8536AT ^[4]	-	-	-	176	252	320	-	1.8 to 5.5	2.5 to 9	60 to 300 ^[2]	N	N	-40 to 85	I ² C	TSSOP56	N
PCF8536BT ^[4]	-	-	-	176	252	320	-	1.8 to 5.5	2.5 to 9	60 to 300 ^[2]	N	N	-40 to 85	SPI	TSSOP56	N
PCA8536AT ^[4]	-	-	-	176	252	320	-	1.8 to 5.5	2.5 to 9	60 to 300 ^[2]	N	N	-40 to 95	I ² C	TSSOP56	Y
PCA8536BT ^[4]	-	-	-	176	252	320	-	1.8 to 5.5	2.5 to 9	60 to 300 ^[2]	N	N	-40 to 95	SPI	TSSOP56	Y
PCF8537AH	44	88	-	176	276	352	-	1.8 to 5.5	2.5 to 9	60 to 300 ^[2]	Y	Y ^[3]	-40 to 85	I ² C	TQFP64	N
PCF8537BH	44	88	-	176	276	352	-	1.8 to 5.5	2.5 to 9	60 to 300 ^[2]	Y	Y ^[3]	-40 to 85	SPI	TQFP64	N
PCA8537AH	44	88	-	176	276	352	-	1.8 to 5.5	2.5 to 9	60 to 300 ^[2]	Y	Y ^[3]	-40 to 95	I ² C	TQFP64	Y
PCA8537BH	44	88	-	176	276	352	-	1.8 to 5.5	2.5 to 9	60 to 300 ^[2]	Y	Y ^[3]	-40 to 95	SPI	TQFP64	Y
PCA9620H	60	120	-	240	320	480	-	2.5 to 5.5	2.5 to 9	60 to 300 ^[2]	Y	Y ^[3]	-40 to 105	I ² C	LQFP80	Y
PCA9620U	60	120	-	240	320	480	-	2.5 to 5.5	2.5 to 9	60 to 300 ^[2]	Y	Y ^[3]	-40 to 105	I ² C	bare die	Y
PCF8552DUG ^[1]	36	72	108	144	-	-	-	1.8 to 5.5	1.8 to 5.5	32 to 128 ^[2]	N	N	-40 to 85	I ² C, SPI	bare die	N
PCA8552DUG ^[1]	36	72	108	144	-	-	-	1.8 to 5.5	1.8 to 5.5	32 to 256 ^[2]	N	N	-40 to 105	I ² C, SPI	bare die	Y
PCF8576DU	40	80	120	160	-	-	-	1.8 to 5.5	2.5 to 6.5	77	N	N	-40 to 85	I ² C	bare die	N
PCF8576EUG	40	80	120	160	-	-	-	1.8 to 5.5	2.5 to 6.5	77	N	N	-40 to 85	I ² C	bare die	N
PCA8576FUG ^[1]	40	80	120	160	-	-	-	1.8 to 5.5	2.5 to 8	200	N	N	-40 to 105	I ² C	bare die	Y
PCF85133U	80	160	240	320	-	-	-	1.8 to 5.5	2.5 to 6.5	82, 110 ^[5]	N	N	-40 to 85	I ² C	bare die	N
PCA85133U	80	160	240	320	-	-	-	1.8 to 5.5	2.5 to 8	82, 110 ^[5]	N	N	-40 to 95	I ² C	bare die	Y
PCA85233U	80	160	240	320	-	-	-	1.8 to 5.5	2.5 to 8	150, 220 ^[5]	N	N	-40 to 105	I ² C	bare die	Y
PCA8530DUG ^[1]	102	204	-	408	-	-	-	2.5 to 5.5	4 to 12	45 to 300 ^[2]	Y	Y ^[3]	-40 to 105	I ² C, SPI	bare die	Y
PCF85132U	160	320	480	640	-	-	-	1.8 to 5.5	1.8 to 8	60 to 90 ^[2]	N	N	-40 to 85	I ² C	bare die	N

Table 37. Selection of LCD segment drivers...continued

Type name	Number of elements at MUX							V _{DD} (V)	V _{LCD} (V)	f _{fr} (Hz)	V _{LCD} (V) charge pump	V _{LCD} (V) temperature compensat.	T _{amb} (°C)	Interface	Package	AEC- Q100
	1:1	1:2	1:3	1:4	1:6	1:8	1:9									
PCA85132U	160	320	480	640	-	-	-	1.8 to 5.5	1.8 to 8	60 to 90 ^[2]	N	N	-40 to 95	I ² C	bare die	Y
PCA85232U	160	320	480	640	-	-	-	1.8 to 5.5	1.8 to 8	117 to 176 ^[2]	N	N	-40 to 95	I ² C	bare die	Y
PCF8538UG ^[1]	102	204	-	408	612	816	918	2.5 to 5.5	4 to 12	45 to 300 ^[2]	Y	Y ^[3]	-40 to 85	I ² C, SPI ^[5]	bare die	N
PCA8538UG	102	204	-	408	612	816	918	2.5 to 5.5	4 to 12	45 to 300 ^[2]	Y	Y ^[3]	-40 to 105	I ² C, SPI ^[5]	bare die	Y

[1] In development.

[2] Can be selected by command.

[3] Extra feature: Temperature sensor.

[4] Extra feature: 6 PWM channels.

[5] Can be selected by pin configuration.

20 Abbreviations

Table 38. Abbreviations

Acronym	Description
CDM	Charged-Device Model
CMOS	Complementary Metal-Oxide Semiconductor
DC	Direct Current
EMC	ElectroMagnetic Compatibility
EPROM	Erasable Programmable Read-Only Memory
ESD	ElectroStatic Discharge
HBM	Human Body Model
I ² C	Inter-Integrated Circuit bus
IC	Integrated Circuit
LCD	Liquid Crystal Display
LSB	Least Significant Bit
MSB	Most Significant Bit
MSL	Moisture Sensitivity Level
MUX	Multiplexer
OTP	One Time Programmable
PCB	Printed-Circuit Board
POR	Power-On Reset
RC	Resistance-Capacitance
RAM	Random Access Memory
RGB	Red Green Blue
RMS	Root Mean Square
SCL	Serial CLock line
SDA	Serial DAta line
SPI	Serial Peripheral Interface

21 References

- [1] JESD22-A114 Electrostatic Discharge (ESD) Sensitivity Testing Human Body Model (HBM)
- [2] JESD22-C101 Field-Induced Charged-Device Model Test Method for Electrostatic-Discharge-Withstand Thresholds of Microelectronic Components
- [3] JESD78 IC Latch-Up Test
- [4] UM10569 Store and transport requirements

22 Revision history

Table 39. Revision history

Document ID	Release date	Data sheet status	Change notice	Supersedes
PCA8546 v.2	20210929	Product data sheet	PCN202102010F01	PCA8546 v.1
Modifications:	<ul style="list-style-type: none">• Updated Ordering information. See Change notice column.• Removed Marking information (formerly Section 5).• The terms "master" and "slave" changed to "controller" and "target" to comply with NXP inclusive language policy.			
PCA8546 v.1	20131113	Product data sheet	-	-

23 Legal information

23.1 Data sheet status

Document status ^{[1][2]}	Product status ^[3]	Definition
Objective [short] data sheet	Development	This document contains data from the objective specification for product development.
Preliminary [short] data sheet	Qualification	This document contains data from the preliminary specification.
Product [short] data sheet	Production	This document contains the product specification.

[1] Please consult the most recently issued document before initiating or completing a design.

[2] The term 'short data sheet' is explained in section "Definitions".

[3] The product status of device(s) described in this document may have changed since this document was published and may differ in case of multiple devices. The latest product status information is available on the Internet at URL <http://www.nxp.com>.

23.2 Definitions

Draft — A draft status on a document indicates that the content is still under internal review and subject to formal approval, which may result in modifications or additions. NXP Semiconductors does not give any representations or warranties as to the accuracy or completeness of information included in a draft version of a document and shall have no liability for the consequences of use of such information.

Short data sheet — A short data sheet is an extract from a full data sheet with the same product type number(s) and title. A short data sheet is intended for quick reference only and should not be relied upon to contain detailed and full information. For detailed and full information see the relevant full data sheet, which is available on request via the local NXP Semiconductors sales office. In case of any inconsistency or conflict with the short data sheet, the full data sheet shall prevail.

Product specification — The information and data provided in a Product data sheet shall define the specification of the product as agreed between NXP Semiconductors and its customer, unless NXP Semiconductors and customer have explicitly agreed otherwise in writing. In no event however, shall an agreement be valid in which the NXP Semiconductors product is deemed to offer functions and qualities beyond those described in the Product data sheet.

23.3 Disclaimers

Limited warranty and liability — Information in this document is believed to be accurate and reliable. However, NXP Semiconductors does not give any representations or warranties, expressed or implied, as to the accuracy or completeness of such information and shall have no liability for the consequences of use of such information. NXP Semiconductors takes no responsibility for the content in this document if provided by an information source outside of NXP Semiconductors. In no event shall NXP Semiconductors be liable for any indirect, incidental, punitive, special or consequential damages (including - without limitation - lost profits, lost savings, business interruption, costs related to the removal or replacement of any products or rework charges) whether or not such damages are based on tort (including negligence), warranty, breach of contract or any other legal theory. Notwithstanding any damages that customer might incur for any reason whatsoever, NXP Semiconductors' aggregate and cumulative liability towards customer for the products described herein shall be limited in accordance with the Terms and conditions of commercial sale of NXP Semiconductors.

Right to make changes — NXP Semiconductors reserves the right to make changes to information published in this document, including without limitation specifications and product descriptions, at any time and without

notice. This document supersedes and replaces all information supplied prior to the publication hereof.

Applications — Applications that are described herein for any of these products are for illustrative purposes only. NXP Semiconductors makes no representation or warranty that such applications will be suitable for the specified use without further testing or modification. Customers are responsible for the design and operation of their applications and products using NXP Semiconductors products, and NXP Semiconductors accepts no liability for any assistance with applications or customer product design. It is customer's sole responsibility to determine whether the NXP Semiconductors product is suitable and fit for the customer's applications and products planned, as well as for the planned application and use of customer's third party customer(s). Customers should provide appropriate design and operating safeguards to minimize the risks associated with their applications and products. NXP Semiconductors does not accept any liability related to any default, damage, costs or problem which is based on any weakness or default in the customer's applications or products, or the application or use by customer's third party customer(s). Customer is responsible for doing all necessary testing for the customer's applications and products using NXP Semiconductors products in order to avoid a default of the applications and the products or of the application or use by customer's third party customer(s). NXP does not accept any liability in this respect.

Limiting values — Stress above one or more limiting values (as defined in the Absolute Maximum Ratings System of IEC 60134) will cause permanent damage to the device. Limiting values are stress ratings only and (proper) operation of the device at these or any other conditions above those given in the Recommended operating conditions section (if present) or the Characteristics sections of this document is not warranted. Constant or repeated exposure to limiting values will permanently and irreversibly affect the quality and reliability of the device.

Terms and conditions of commercial sale — NXP Semiconductors products are sold subject to the general terms and conditions of commercial sale, as published at <http://www.nxp.com/profile/terms>, unless otherwise agreed in a valid written individual agreement. In case an individual agreement is concluded only the terms and conditions of the respective agreement shall apply. NXP Semiconductors hereby expressly objects to applying the customer's general terms and conditions with regard to the purchase of NXP Semiconductors products by customer.

No offer to sell or license — Nothing in this document may be interpreted or construed as an offer to sell products that is open for acceptance or the grant, conveyance or implication of any license under any copyrights, patents or other industrial or intellectual property rights.

Suitability for use in automotive applications — This NXP product has been qualified for use in automotive applications. If this product is used by customer in the development of, or for incorporation into, products or services (a) used in safety critical applications or (b) in which failure could lead to death, personal injury, or severe physical or environmental damage (such products and services hereinafter referred to as "Critical Applications"),

then customer makes the ultimate design decisions regarding its products and is solely responsible for compliance with all legal, regulatory, safety, and security related requirements concerning its products, regardless of any information or support that may be provided by NXP. As such, customer assumes all risk related to use of any products in Critical Applications and NXP and its suppliers shall not be liable for any such use by customer. Accordingly, customer will indemnify and hold NXP harmless from any claims, liabilities, damages and associated costs and expenses (including attorneys' fees) that NXP may incur related to customer's incorporation of any product in a Critical Application.

Export control — This document as well as the item(s) described herein may be subject to export control regulations. Export might require a prior authorization from competent authorities.

Translations — A non-English (translated) version of a document is for reference only. The English version shall prevail in case of any discrepancy between the translated and English versions.

23.4 Trademarks

Notice: All referenced brands, product names, service names and trademarks are the property of their respective owners.

I²C-bus — logo is a trademark of NXP B.V.

NXP — wordmark and logo are trademarks of NXP B.V.

Tables

Tab. 1.	Ordering information	2	Tab. 17.	Load-data-pointer - load data pointer command bit description	15
Tab. 2.	Ordering options	2	Tab. 18.	Write-RAM-data - write RAM data command bit description	16
Tab. 3.	Pin description of PCA8546ATT and PCA8546BTT	6	Tab. 19.	Starting conditions	16
Tab. 4.	Commands of PCA8546	7	Tab. 20.	Display configuration	19
Tab. 5.	Initialize - initialize command bit description	7	Tab. 21.	Preferred LCD drive modes: summary of characteristics	20
Tab. 6.	OTP-refresh - OTP-refresh command bit description	8	Tab. 22.	Control byte description	27
Tab. 7.	Mode-settings - mode settings command bit description	8	Tab. 23.	I2C target address byte	30
Tab. 8.	Effect of the power-down bit (PD)	10	Tab. 24.	R/W-bit description	30
Tab. 9.	Oscillator-control - oscillator control command bit description	11	Tab. 25.	Status read out value	31
Tab. 10.	Valid combinations of bits OSC, EFR, and COE	12	Tab. 26.	Modified status read out value	32
Tab. 11.	Typical use of bits OSC, EFR, and COE	12	Tab. 27.	Serial interface	32
Tab. 12.	OSCCLK pin state depending on configuration	13	Tab. 28.	Subaddress byte definition	32
Tab. 13.	LCD frame frequencies	13	Tab. 29.	Limiting values	35
Tab. 14.	Set-bias-mode - set bias mode command bit description	14	Tab. 30.	Static characteristics	35
Tab. 15.	Frame-frequency - frame frequency and output clock frequency command bit description	14	Tab. 31.	Dynamic characteristics	39
Tab. 16.	Frame frequency prescaler values for 230 kHz clock operation	14	Tab. 32.	Timing characteristics: I2C-bus	40
			Tab. 33.	Timing characteristics: SPI-bus	42
			Tab. 34.	Carrier tape dimensions of PCA8546ATT and PCA8546BTT	45
			Tab. 35.	SnPb eutectic process (from J-STD-020D)	47
			Tab. 36.	Lead-free process (from J-STD-020D)	47
			Tab. 37.	Selection of LCD segment drivers	51
			Tab. 38.	Abbreviations	54
			Tab. 39.	Revision history	55

Figures

Fig. 1.	Block diagram of PCA8546A	3	Fig. 17.	Display RAM filling order in 1:4 multiplex drive mode	26
Fig. 2.	Block diagram of PCA8546B	4	Fig. 18.	Boundary condition in 1:4 multiplex drive mode	27
Fig. 3.	Pin configuration for TSSOP56 (PCA8546ATT)	5	Fig. 19.	Control byte format	28
Fig. 4.	Pin configuration for TSSOP56 (PCA8546BTT)	5	Fig. 20.	Bit transfer	28
Fig. 5.	Effect of backplane swapping	9	Fig. 21.	Definition of START and STOP conditions	28
Fig. 6.	Recommended power-down sequence	10	Fig. 22.	System configuration	29
Fig. 7.	Oscillator selection	12	Fig. 23.	Acknowledgement on the I2C-bus	29
Fig. 8.	Recommended start-up sequence when using an external clock signal	17	Fig. 24.	I2C-bus protocol write mode	31
Fig. 9.	Recommended start-up sequence when using the internal oscillator	18	Fig. 25.	I2C-bus protocol read mode	31
Fig. 10.	Example of displays suitable for PCA8546	19	Fig. 26.	Data transfer overview	32
Fig. 11.	Typical system configuration for the I2C-bus	19	Fig. 27.	SPI-bus write example	33
Fig. 12.	Typical system configuration for the SPI-bus	20	Fig. 28.	SPI-bus example	33
Fig. 13.	Electro-optical characteristic: relative transmission curve of the liquid	22	Fig. 29.	Device protection diagram for PCA8546A	34
Fig. 14.	Waveforms for the 1:4 multiplex drive mode with 1/3 bias and line inversion	23	Fig. 30.	Device protection diagram for PCA8546B	34
Fig. 15.	Waveforms for 1:4 multiplex drive mode with 1/3 bias and frame inversion	24	Fig. 31.	Typical IDD with respect to temperature	38
Fig. 16.	Display RAM bitmap	25	Fig. 32.	Typical IDD(LCD) in power-down mode with respect to temperature	38
			Fig. 33.	Typical IDD(LCD) when display is active with respect to temperature	39
			Fig. 34.	Typical clock frequency with respect to VDD and temperature	40
			Fig. 35.	Driver timing waveforms	40
			Fig. 36.	RESET timing	40

Fig. 37.	I2C-bus timing waveforms	42	Fig. 41.	Temperature profiles for large and small components	47
Fig. 38.	SPI-bus timing	43	Fig. 42.	Footprint information for reflow soldering of SOT364-1 (TSSOP56) package	49
Fig. 39.	Package outline SOT364-1 (TSSOP56)	44			
Fig. 40.	Tape and reel details for PCA8546ATT and PCA8546BTT	45			