

UM11556

PCA9450 evaluation board user manual

Rev. 1.0 — 12 January 2021

User manual

Document information

Information	Content
Keywords	PCA9450, Evaluation Board, PMIC
Abstract	User manual for PCA9450 family PMIC evaluation board



Revision history

Rev	Date	Description
v.1.0	20210112	Initial version

1 Introduction

The PCA9450 is a single chip Power Management IC (PMIC) specifically designed to support the i.MX 8M family processors in both 1 cell Li-Ion and Li-polymer battery portable application and 5 V adapter non-portable applications.

The device provides six high efficiency step-down regulators, five LDOs, one 400 mA load switch, 2-channel level translator and 32.768 kHz crystal oscillator driver. Three buck regulators support Dynamic Voltage Scaling (DVS) feature along with programmable ramping up and down time, and those buck regulators support remote sense to compensate IR drop to load. This device is characterized across -40 °C to 105 °C ambient temperature range.

Six step-down regulators are designed to provide power for the i.MX 8M application processor and DRAM memory. Two LDOs, LDO1 and LDO2, feature very low quiescent current to provide power for Secure Non-Volatile Storage (SNVS) since these LDOs are always ON when input voltage is valid.

PCA9450 integrates a 2-bit logic translator and dual supply translating transceiver with auto direction sensing. It enables bidirectional voltage level translation and can be used as an I²C level translator. 400 mA load switch is to supply 3.3 V power supply to SD card, which has internal discharge resistor.

PCA9450 has three versions: PCA9450AA is companion PMIC for i.MX 8M Mini, PCA9450B is companion PMIC for i.MX 8M Nano and PCA9450C is companion PMIC for i.MX 8M Plus.

The PCA9450 is offered in 56-pin HVQFN package, 7 mm x 7 mm, 0.4 mm pitch.

2 Key Features

- Six high efficiency step-down regulators
 - Three 3 A Buck regulators with DVS feature and remote sense
 - PCA9450AA – Three 3 A buck regulators
 - PCA9450B – Two 3 A buck regulators
 - PCA9450C – 6 A dual-phase buck regulator and 3 A buck regulator
 - One 3 A buck regulator
 - Two 2 A buck regulators
- Five linear regulators
 - Two 10 mA LDOs
 - One 150 mA LDO
 - One 200 mA LDO
 - One 300 mA LDO
- Support various memory types: DDR4/LPDDR4/DDR3L via system UBOOT configuration, no hardware change required
- 400 mA load switch with active discharge
- 32.768 kHz crystal oscillator buffer output
- 2-channel level translator
- Power control IOs
 - Power ON/OFF control
 - Standby/run mode control
- Fm+ 1 MHz I²C-bus interface

- ESD protection
 - Human Body Model (HBM) : +/- 2000 V
 - Charged Device Model (CDM) : +/-500 V
- 7 mm x 7 mm, 56 pin HVQFN with 0.4 mm pitch

3 Applications

- IoT Devices
- Tablet
- Electronic Point of Sale (ePOS)
- Industrial application

4 Evaluation kit components

There are three evaluation boards for the PCA9450 family device: PCA9450AA-EVK, PCA9450B-EVK and PCA9450C-EVK. When evaluating the device, the kits below are required:

- 1x PCA9450 evaluation board, which allows easy evaluation on function and features
- 1x Interface ([FTDI C232HM-EDHSL-0](#)) cable, serves as a USB to I²C-bus interface between the computer and the PCA9450 evaluation board
- A Windows based Graphic User Interface (GUI) provides a user friendly interface to program on-chip I²C registers to exercise the feature on PCA9450

5 PCA9450 GUI software

- Unzip the provided PCA9450 Evaluation Kit GUI file into selected folder. No need to install. If password is asked during unzip, type "NXP".
- Install the FTDI cable driver from website <https://www.ftdichip.com/Drivers/D2XX.htm>.
- Run the file PCA9450.exe. The interface is shown in [Figure 1](#).

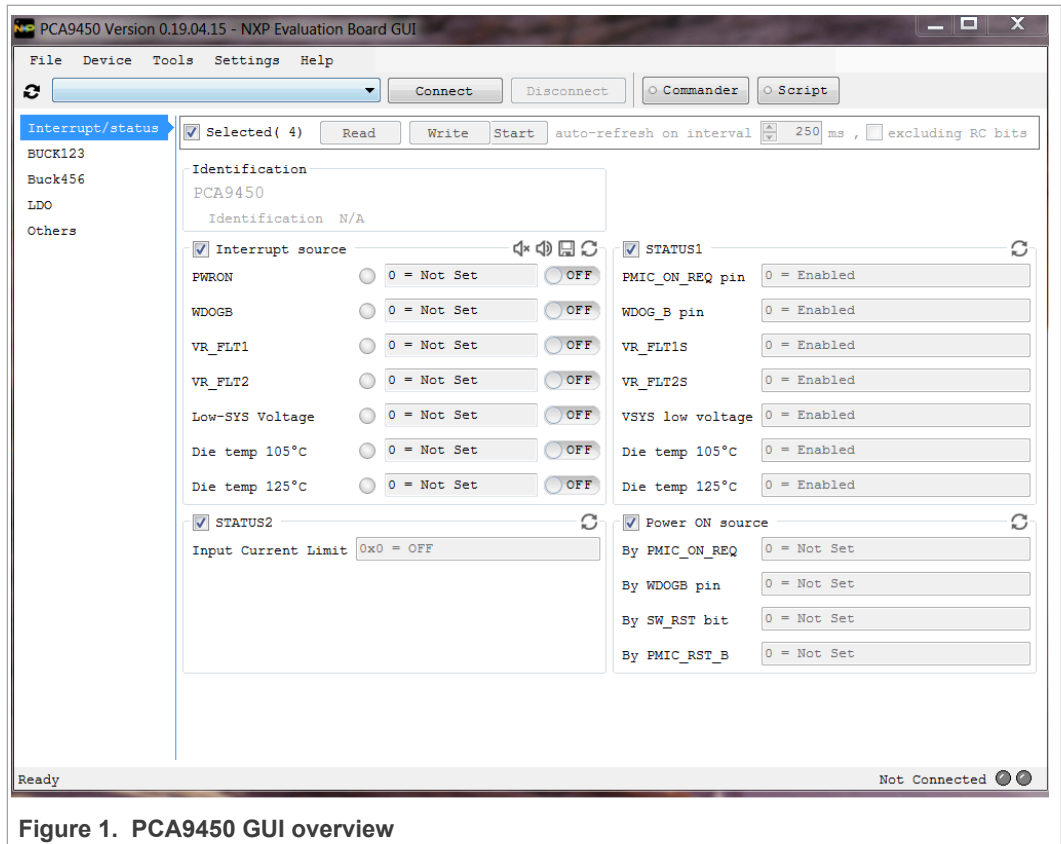

Figure 1. PCA9450 GUI overview

6 Test setup and evaluation board connections

6.1 Test equipment

- PC/laptop with Windows 7/Windows 10 OS
- Power supply (5 V typical)
- Electronic load
- Oscilloscope/multimeter
- FTDI cable C232HM-DDHSL-0

6.2 Test setup

[Figure 2](#) shows test setup block diagram.

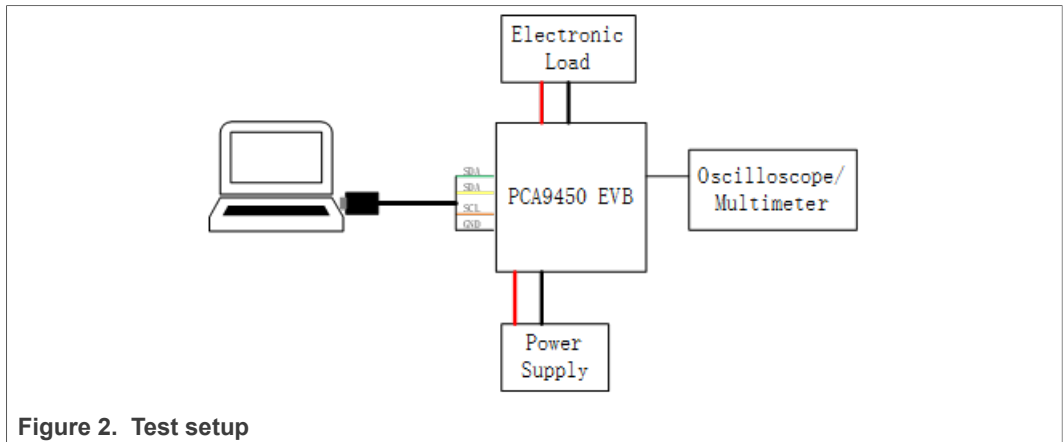

Figure 2. Test setup

6.3 Evaluation board connection

Figure 3 shows the evaluation board test pin assignment.

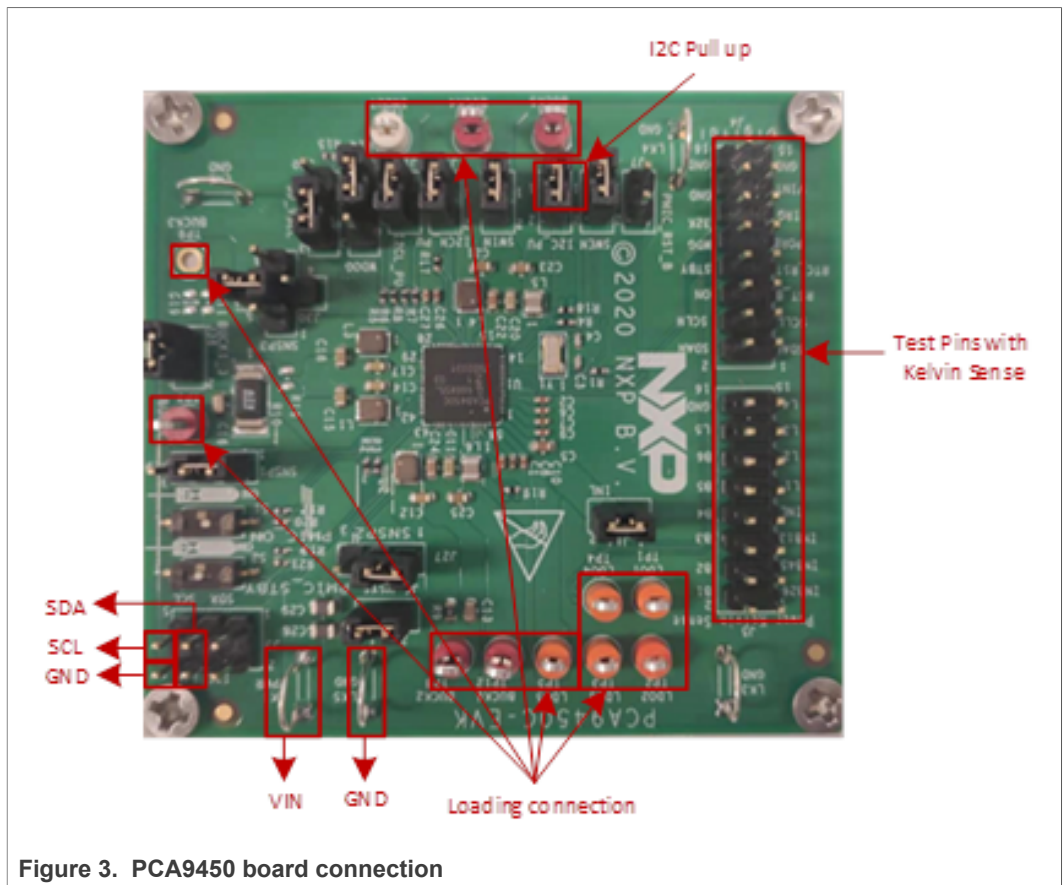

Figure 3. PCA9450 board connection

Below is evaluation board jumper/switch settings.

Table 1. Jumper/switch settings

Jumpers/ Switch	Settings	Description
S1	ON (default)	PMIC_ON_REQ =High

Table 1. Jumper/switch settings...continued

Jumpers/ Switch	Settings	Description
S2	OFF (default)	PMIC_STBY_REQ =Low
J6	1-2 (default)	VSYS Enablement
J7	No connection (default)	PMIC_RST_B
J10	1-2 (default)	Pull up of WDOG_B
J11	1-2 (default)	Pull up of SDA,SCL, IRQ_B
J12	1-2 (default)	Pull up of SCLL,SDAL
J13	1-2 (default)	Pull up of SCLH,SDAH
J14	1-2 (default)	INL1 Enablement
J20	2-3 (default)	SD_VSEL = Low
J27	1-2 (default)	BUCK2 Feedback connection: R_SNSP2
J29	1-2 (default)	BUCK1 Feedback connection: R_SNSP1
J30	PCA9450AA-EVK: 2-3 (default) PCA9450B-EVK: 2-4 (default) PCA9450C-EVK: 2-5 (default)	BUCK3 Feedback connection: R_SNSP3
J33	1-2 (default)	SWIN Connect to BUCK4
J34	1-2 (default)	SW_EN connect to BUCK4
J36	PCA9450AA-EVK: No connection (default) PCA9450B-EVK: No connection (default) PCA9450C-EVK: 1-2 (default)	BUCK1&BUCK3 Single/Dual Phase

6.4 Connection

Connect wires on the following pins as shown in [Figure 3](#) and make sure the power supply is turned off during the wiring stage:

- VIN and GND – Connect to external power supply.
- SDA/SCL and GND – Connect to FTDI USB to I²C cable. See [Figure 4](#).
- It can use either external power or buck 5 output for I²C pull up.
- Each power rail output can be connected to e-load for testing.
- Use the test pin to measure the voltage signal by oscilloscope/multimeter.

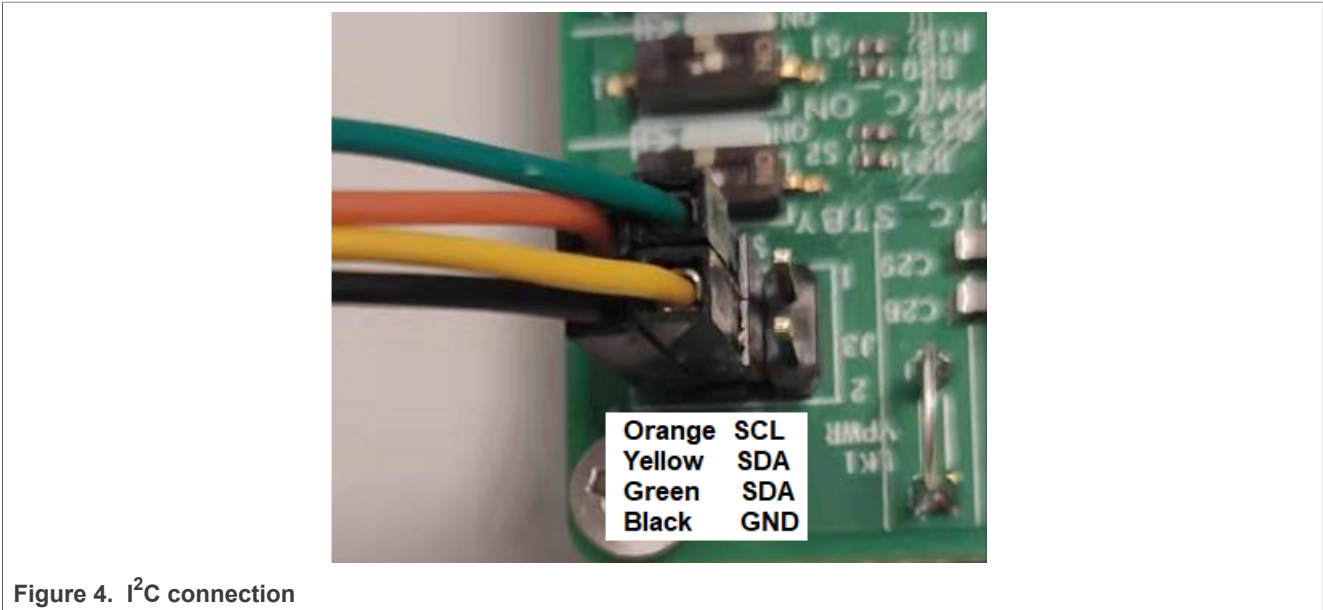

Figure 4. I²C connection

7 PCA9450 GUI quick guide

As shown in [Figure 5](#), the GUI is a user friendly tool to access the on-chip registers to perform write/read commands manually or automatically (depending on different setting chosen from the GUI). Below is a quick guide of the key blocks that the GUI provides.

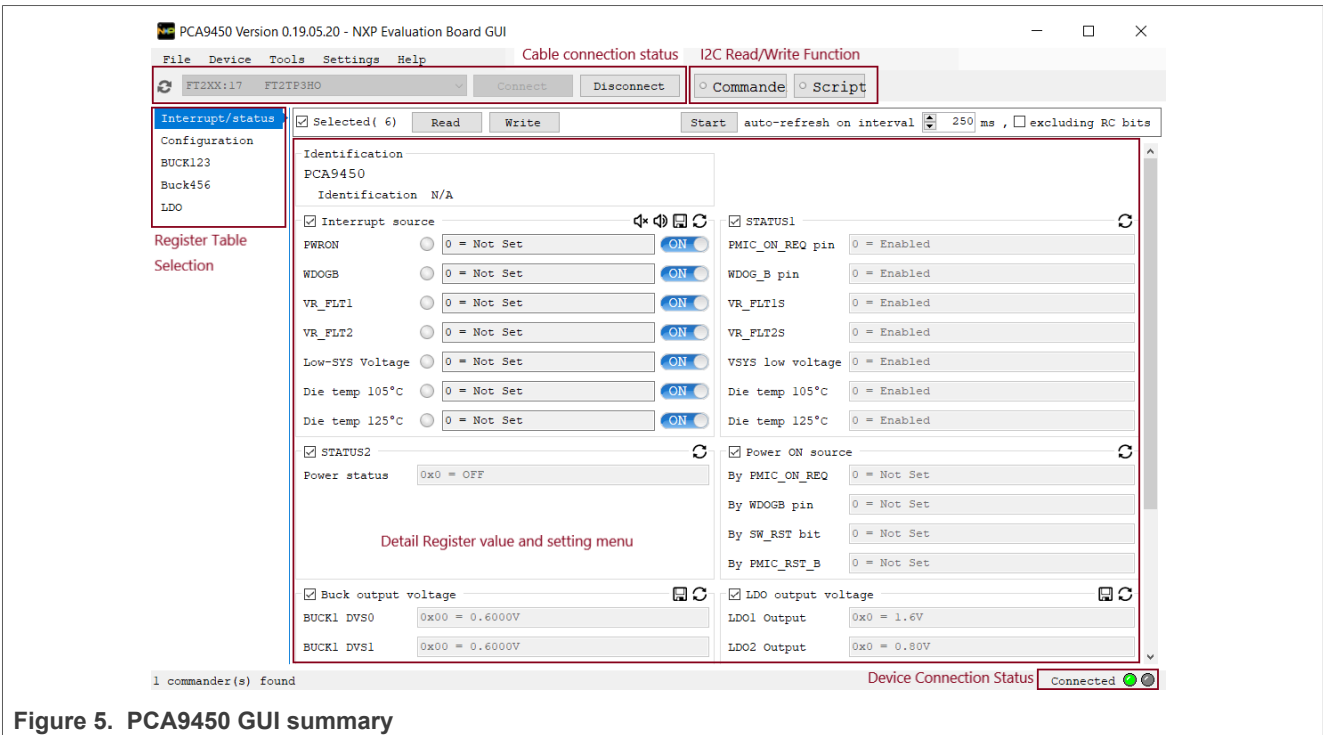

Figure 5. PCA9450 GUI summary

7.1 Connection

After plugging in FTDI cable, GUI will detect cable automatically. Select the cable type (FT2TP3HO) from drop-down menu, and then click “Connect” button. Turn on the input power supply; it will show “connected” with green light in the right bottom, “Device connection status”.



7.2 Register table selection

The registers are categorized for easy use.

- Interrupt/Status – Interrupt, buck/LDO output voltage, fault information, power on source.
- Configuration – Reset behavior, debounce time, UVLO threshold and buck/LDO output status.
- Buck123 – Buck1, 2, 3 configuration.
- Buck456 – Buck4, 5, 6 configuration.
- LDO – LDOs and load switch configuration.

7.3 I²C read and write

PCA9450 GUI provides three ways to read and write:

- On register table, click the “read” “write” button for the whole table, or click “” for write and “” for read.
- Command: Read or write the Hex value to specific register.
- Script: Run the script to read or write a series of registers. User guide can be found in help menu.

8 PCA9450 evaluation steps

1. Connect the 3.3 V power to I²C pull up if using external pull up.
2. Connect the jumper as default which is marked with green in schematic.
3. Connect the board to power and PC accordingly.
4. Turn on power supply (5 V) on Vin.
5. Turn on the loading.

9 Evaluation board schematic

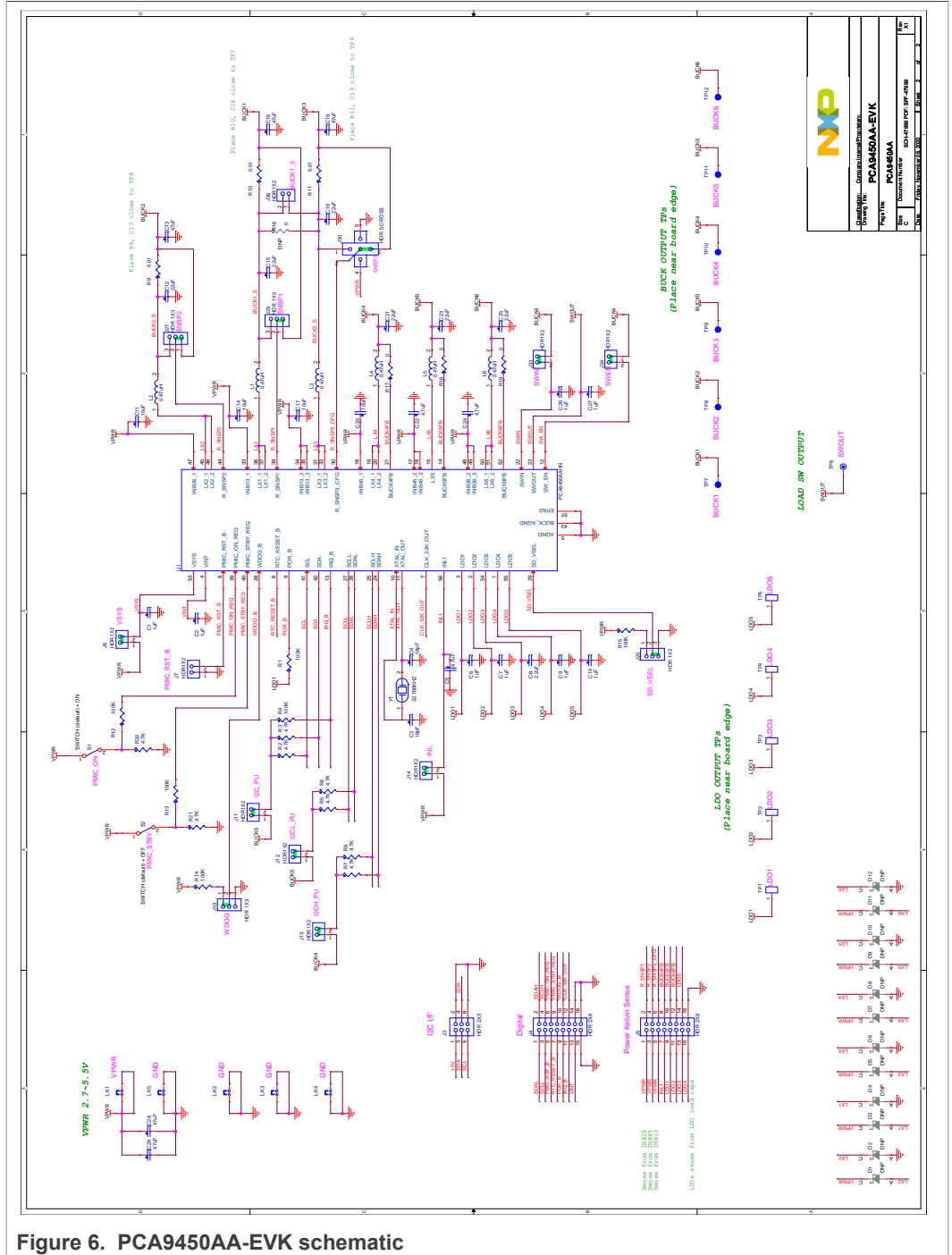

Figure 6. PCA9450AA-EVK schematic

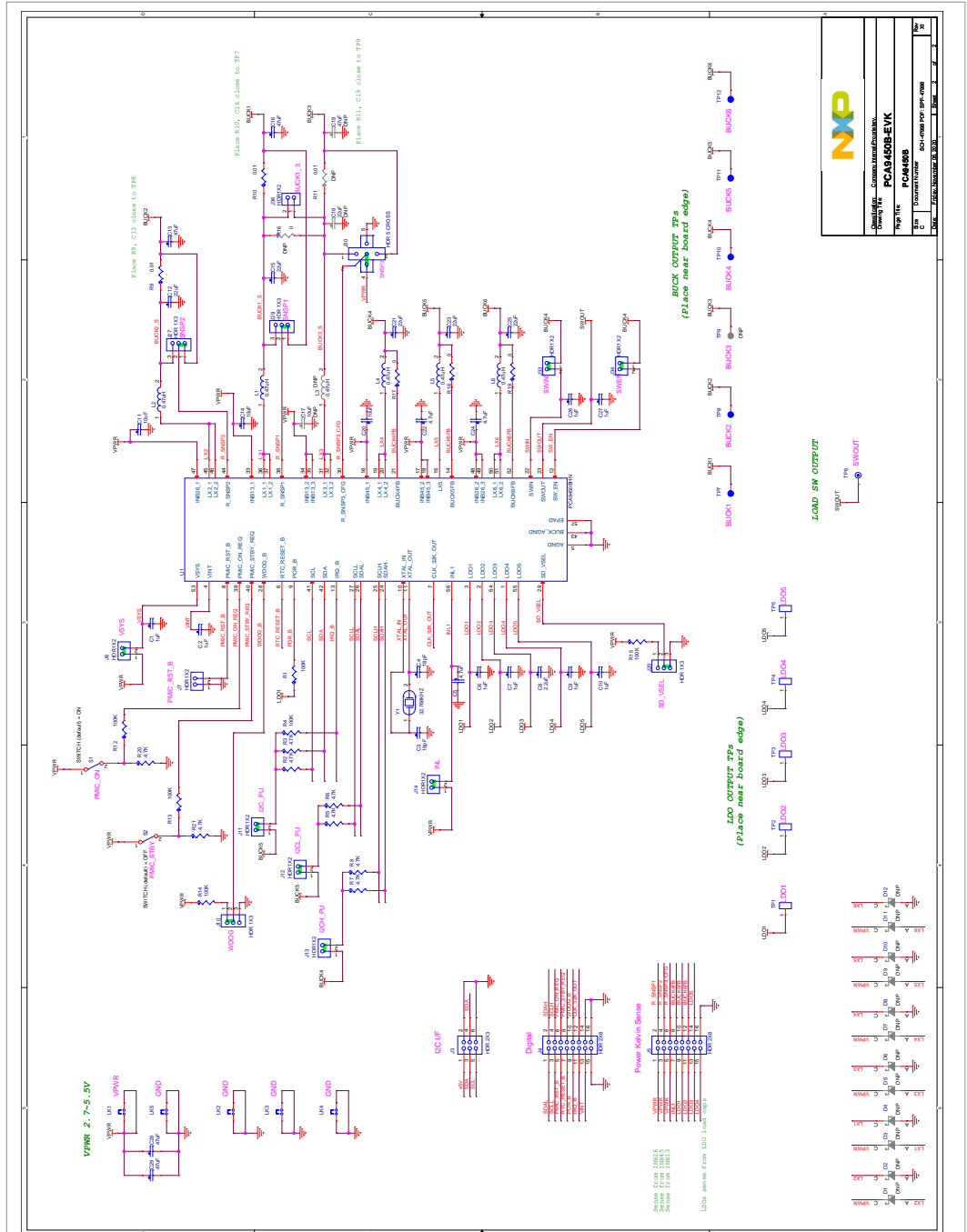

Figure 7. PCA9450B-EVK schematic

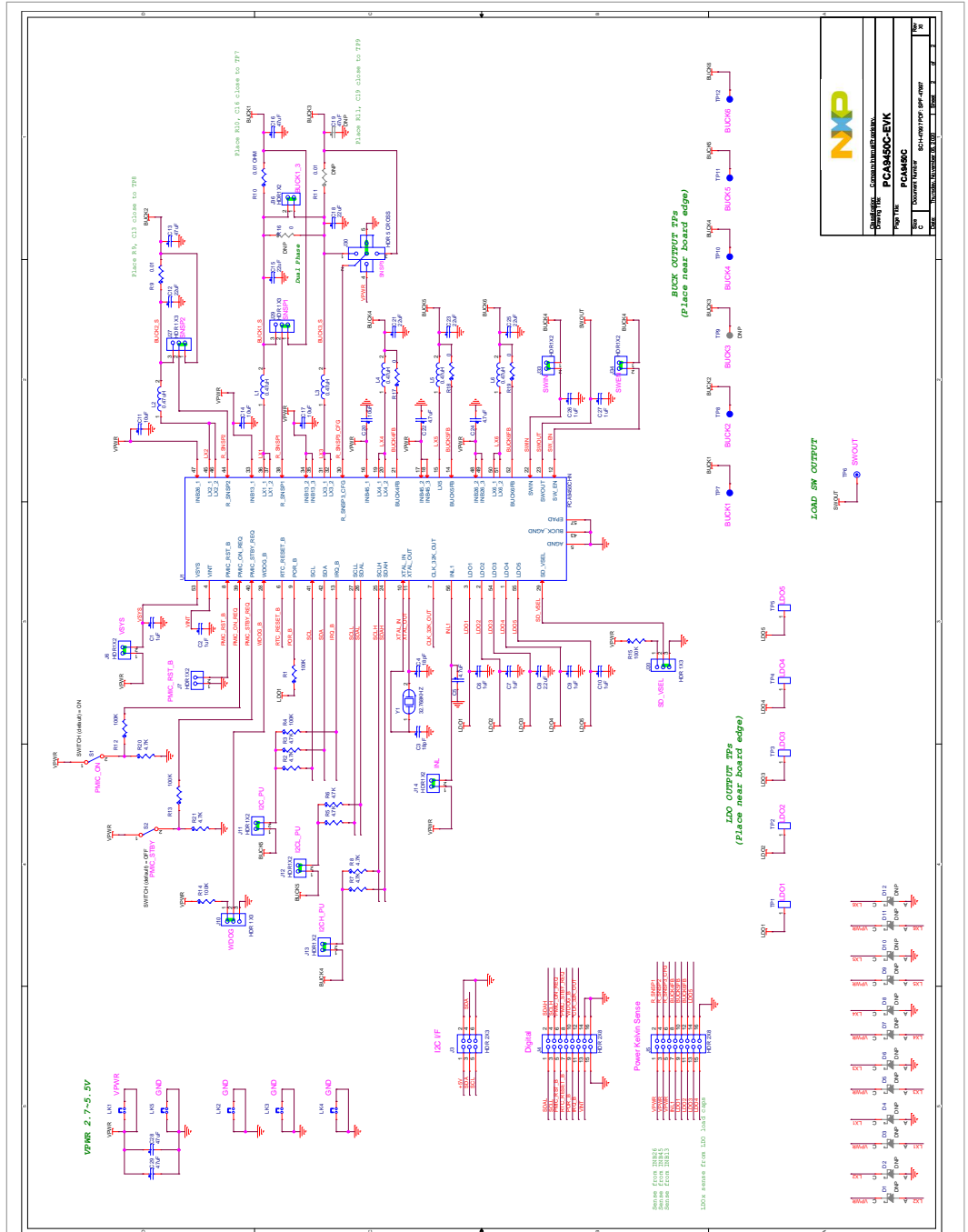
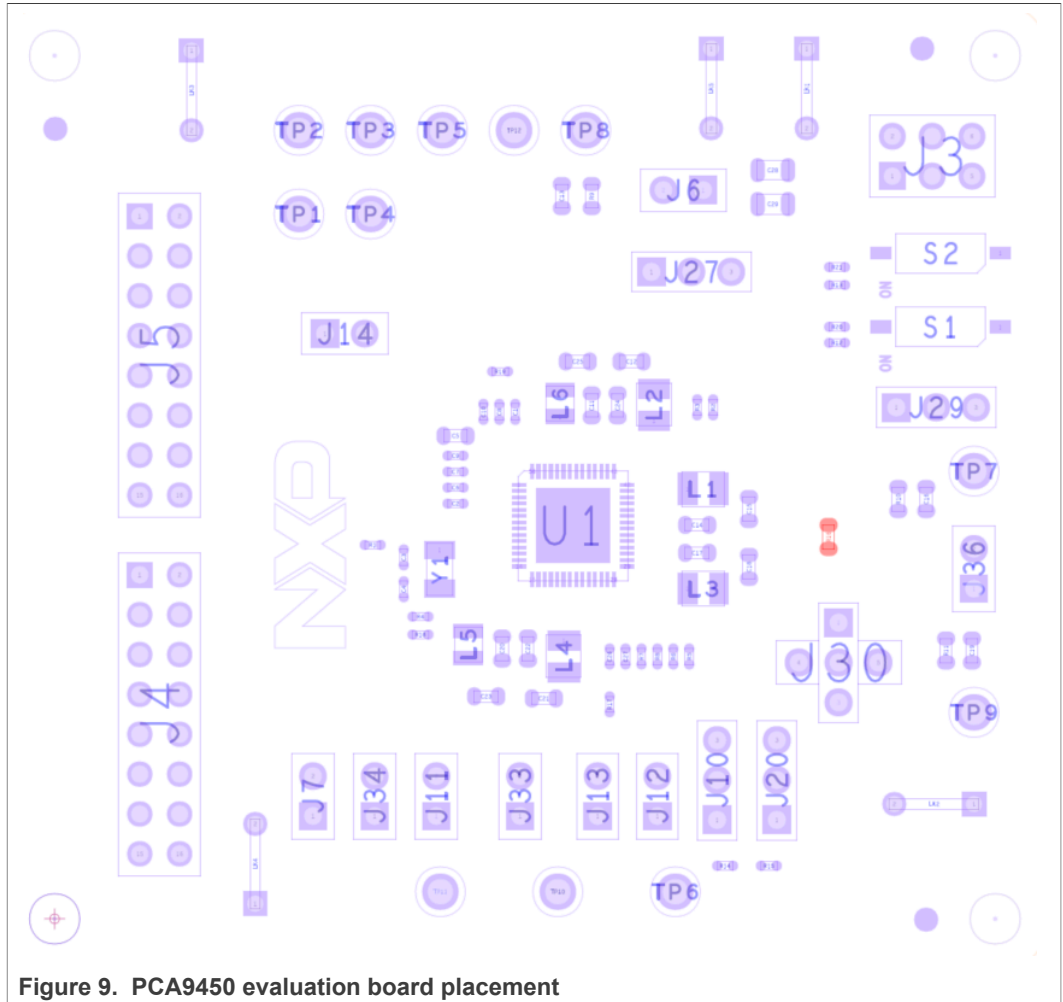

Figure 8. PCA9450C-EVK schematic

10 Placement



11 BOM

Qty	ASSY_OPT	Value	Part Reference	DESCRIPTION	MFG_NAME01	MFG_PN01
8		1uF	C1,C2,C6,C7,C9,C10,C26,C27	CAP CER 1uF 10V 10% X7S 0402	MURATA	GRM155C71A105KE11D
2		18pF	C3,C4	CAP CER 18pF 50V 5% C0G AEC-Q200 0402	MURATA	GCM1555C1H180JA16
3		4.7uF	C5,C22,C24	CAP CER 4.7uF 10V 10% X7S 0603	MURATA	GRM188C71A475KE11D
1		2.2uF	C8	CAP CER 2.2uF 16V 10% X5R 0402	MURATA	GRM155R61C225KE44
4		10uF	C11,C14,C17,C20	CAP CER 10UF 10V 10% X5R 0603	MURATA	GRM188R61A106KE69D
4		22uF	C12,C15,C18,C21	CAP CER 22uF 10V 20% X5R 0603	TDK	C1608X5R1A226M080AC
3		47uF	C13,C16,C19	CAP CER 47UF 6.3V 20% X5R 0603	MURATA	GRM188R60J476ME15D
2		10UF	C23,C25	CAP CER 10UF 6.3V 10% X5R 0603	MURATA	GRM188R60J106KE47D
2		47uF	C28,C29	CAP CER 47uF 10V 20% X5R 0805	TDK	C2012X5R1A476M125AC
12	DNP	PMEG4030ER	D1-D12	DIODE SCH RECT 3A 40V AEC-Q101 SOD123W	NEXPERIA	PMEG4030ER,115
1		HDR 2X3	J3	HDR 2X3 TH 100MIL CTR 344H AU 118L	WURTH ELEKTRONIK EISOS GMBH & CO. KG (ELECTRONIC & ELECTROMECHANICAL COMP)	61300621121
2		HDR 2X8	J4,J5	HDR 2X8 TH 100MIL CTR 344H AU 118L	WURTH ELEKTRONIK EISOS GMBH & CO. KG (ELECTRONIC & ELECTROMECHANICAL COMP)	61301621121
9		HDR1X2	J6,J7,J11-J14,J33,J34,J36	HDR 1X2 TH 100MIL SP 342H AU 118L	WURTH ELEKTRONIK EISOS GMBH & CO. KG (ELECTRONIC & ELECTROMECHANICAL COMP)	61300211121
2		SW DIP 1 POS	S1,S2	SW DIP 1 POS 0.025A@24VDC SMT	WURTH ELEKTRONIK EISOS GMBH & CO. KG (ELECTRONIC & ELECTROMECHANICAL COMP)	416131160801

Qty	ASSY_OPT	Value	Part Reference	DESCRIPTION	MFG_NAME01	MFG_PN01
6		HDR 1X3	J10,J20,J27,J29	HDR 1X3 TH 2.54MM SP 344H AU 118L	WURTH ELEKTRONIK EISOS GMBH & CO. KG (ELECTRONIC & ELECTROMECHANICAL COMP)	61300311121
1		HDR 5 CROSS	J30	SUBASSEMBLY HDR 1X3 TH 2.54MM SP 344H AU 118L + HDR 1X1 TH -- 344H AU 118L	SUBASSEMBLY	210-80732,210-81266
4		0.47uH	L1-L4	IND PWR 0.47uH@1MHZ 4.7A 20% SMT	Shenzhen Sunlord Electronics Co., Ltd	WPN252012ER47MT
2		0.47uH	L5,L6	IND WW 0.47uH@1MHz 3.4A 20% 2016	MURATA	1286AS-H-R47M=P2
5		JUMPER_200MIL	LK1-LK5	CON 2 JUMPER PLUG SHORTING TH 200MIL SP 300H --	KEYSTONE ELECTRONICS	5026
6		100K	R1,R4,R12-R15	RES MF 100K 1/10W 5% AEC-Q200 0402	KOA SPEER	RK73B1ETTP104J
6		4.7K	R2,R3,R5-R8	RES MF 4.7K 1/10W 5% AEC-Q200 0402	KOA SPEER	RK73B1ETTP472J
3		0.01	R9-R11	RES MF 0.01 OHM 1/10W 1% AEC-Q200 0603	Yageo	RL0603FR-070R01L
1	DNP	0	R16	RES MF ZERO OHM -- AEC-Q200 0603	KOA SPEER	RK73Z1JTDD
3		0	R17-R19	RES MF ZERO OHM 1/16W 5% 0402	ROHM	MCR01MZPJ000
5		TEST POINT	TP1-TP5	TEST POINT ORANGE 70X220 MIL TH	KEYSTONE ELECTRONICS	5008
1		5007	TP6	TEST POINT WHITE 70X220 MIL TH	KEYSTONE ELECTRONICS	5007
6		TESTLOOP_RED	TP7-TP12	TEST POINT PC MULTI PURPOSE RED TH	KEYSTONE ELECTRONICS	5010
1		PCA9450AA/ PCA9450B/ PCA9450C	U1	IC POWER MANAGEMENT 2.7-5.5V HVQFN56	NXP SEMICONDUCTORS	PCA9450AA/ PCA9450B/ PCA9450C
1		32.768KHZ	Y1	XTAL 32.768KHZ 12.5PF 20PPM 3.2X1.5MM SMT	Abracon Corporation	ABS07-32.768KHZ-T

12 Notes

13 Legal information

13.1 Definitions

Draft — A draft status on a document indicates that the content is still under internal review and subject to formal approval, which may result in modifications or additions. NXP Semiconductors does not give any representations or warranties as to the accuracy or completeness of information included in a draft version of a document and shall have no liability for the consequences of use of such information.

13.2 Disclaimers

Limited warranty and liability — Information in this document is believed to be accurate and reliable. However, NXP Semiconductors does not give any representations or warranties, expressed or implied, as to the accuracy or completeness of such information and shall have no liability for the consequences of use of such information. NXP Semiconductors takes no responsibility for the content in this document if provided by an information source outside of NXP Semiconductors. In no event shall NXP Semiconductors be liable for any indirect, incidental, punitive, special or consequential damages (including - without limitation - lost profits, lost savings, business interruption, costs related to the removal or replacement of any products or rework charges) whether or not such damages are based on tort (including negligence), warranty, breach of contract or any other legal theory. Notwithstanding any damages that customer might incur for any reason whatsoever, NXP Semiconductors' aggregate and cumulative liability towards customer for the products described herein shall be limited in accordance with the Terms and conditions of commercial sale of NXP Semiconductors.

Right to make changes — NXP Semiconductors reserves the right to make changes to information published in this document, including without limitation specifications and product descriptions, at any time and without notice. This document supersedes and replaces all information supplied prior to the publication hereof.

Suitability for use — NXP Semiconductors products are not designed, authorized or warranted to be suitable for use in life support, life-critical or safety-critical systems or equipment, nor in applications where failure or malfunction of an NXP Semiconductors product can reasonably be expected to result in personal injury, death or severe property or environmental damage. NXP Semiconductors and its suppliers accept no liability for inclusion and/or use of NXP Semiconductors products in such equipment or applications and therefore such inclusion and/or use is at the customer's own risk.

Applications — Applications that are described herein for any of these products are for illustrative purposes only. NXP Semiconductors makes no representation or warranty that such applications will be suitable for the specified use without further testing or modification. Customers are responsible for the design and operation of their applications and products using NXP Semiconductors products, and NXP Semiconductors accepts no liability for any assistance with applications or customer product design. It is customer's sole responsibility to determine whether the NXP Semiconductors product is suitable and fit for the customer's applications and products planned, as well as for the planned application and use of customer's third party customer(s). Customers should provide appropriate design and operating safeguards to minimize the risks associated with their applications and products. NXP Semiconductors does not accept any liability related to any default, damage, costs or problem which is based on any weakness or default in the customer's applications or products, or

the application or use by customer's third party customer(s). Customer is responsible for doing all necessary testing for the customer's applications and products using NXP Semiconductors products in order to avoid a default of the applications and the products or of the application or use by customer's third party customer(s). NXP does not accept any liability in this respect.

Export control — This document as well as the item(s) described herein may be subject to export control regulations. Export might require a prior authorization from competent authorities.

Evaluation products — This product is provided on an "as is" and "with all faults" basis for evaluation purposes only. NXP Semiconductors, its affiliates and their suppliers expressly disclaim all warranties, whether express, implied or statutory, including but not limited to the implied warranties of non-infringement, merchantability and fitness for a particular purpose. The entire risk as to the quality, or arising out of the use or performance, of this product remains with customer. In no event shall NXP Semiconductors, its affiliates or their suppliers be liable to customer for any special, indirect, consequential, punitive or incidental damages (including without limitation damages for loss of business, business interruption, loss of use, loss of data or information, and the like) arising out of the use of or inability to use the product, whether or not based on tort (including negligence), strict liability, breach of contract, breach of warranty or any other theory, even if advised of the possibility of such damages. Notwithstanding any damages that customer might incur for any reason whatsoever (including without limitation, all damages referenced above and all direct or general damages), the entire liability of NXP Semiconductors, its affiliates and their suppliers and customer's exclusive remedy for all of the foregoing shall be limited to actual damages incurred by customer based on reasonable reliance up to the greater of the amount actually paid by customer for the product or five dollars (US\$5.00). The foregoing limitations, exclusions and disclaimers shall apply to the maximum extent permitted by applicable law, even if any remedy fails of its essential purpose.

Translations — A non-English (translated) version of a document is for reference only. The English version shall prevail in case of any discrepancy between the translated and English versions.

Security — Customer understands that all NXP products may be subject to unidentified or documented vulnerabilities. Customer is responsible for the design and operation of its applications and products throughout their lifecycles to reduce the effect of these vulnerabilities on customer's applications and products. Customer's responsibility also extends to other open and/or proprietary technologies supported by NXP products for use in customer's applications. NXP accepts no liability for any vulnerability. Customer should regularly check security updates from NXP and follow up appropriately. Customer shall select products with security features that best meet rules, regulations, and standards of the intended application and make the ultimate design decisions regarding its products and is solely responsible for compliance with all legal, regulatory, and security related requirements concerning its products, regardless of any information or support that may be provided by NXP. NXP has a Product Security Incident Response Team (PSIRT) (reachable at PSIRT@nxp.com) that manages the investigation, reporting, and solution release to security vulnerabilities of NXP products.

13.3 Trademarks

Notice: All referenced brands, product names, service names and trademarks are the property of their respective owners.

NXP — wordmark and logo are trademarks of NXP B.V.