

UM11579

PCA9957HN-ARD evaluation board

Rev. 1 — 25 February 2021

User manual

Document information

Information	Content
Keywords	PCA9957HN, SPI, Arduino port, EVK, LED, LED driver
Abstract	The PCA9957HN-ARD evaluation board is a daughter card equipped with Arduino ports, designated for easy test and design of the PCA9957HN IC, 24-channel SPI serial bus 32 mA/5.5 V constant current LED driver. The board is fully compliant with IMXRT1050-EVKB, LPCXpresso55S69 (LPC55S69-EVK) and i.MX 8M Mini LPDDR4 EVK (8MMINILPD4-EVK) (8MMINID4-EVK), including GUI software control. The board can be attached to any device equipped with Arduino ports.



1 Revision History

Table 1. Revision history

Rev	Date	Description
v.1	02/25/2021	Initial version

Important Notice

NXP provides the enclosed product(s) under the following conditions:

This evaluation kit is intended for use of ENGINEERING DEVELOPMENT OR EVALUATION PURPOSES ONLY. It is provided as a sample IC pre-soldered to a printed circuit board to make it easier to access inputs, outputs, and supply terminals. This evaluation board may be used with any development system or other source of I/O signals by simply connecting it to the host MCU or computer board via off-the-shelf cables. This evaluation board is not a Reference Design and is not intended to represent a final design recommendation for any particular application. Final device in an application will be heavily dependent on proper printed circuit board layout and heat sinking design as well as attention to supply filtering, transient suppression, and I/O signal quality.

The goods provided may not be complete in terms of required design, marketing, and or manufacturing related protective considerations, including product safety measures typically found in the end product incorporating the goods. Due to the open construction of the product, it is the user's responsibility to take any and all appropriate precautions with regard to electrostatic discharge. In order to minimize risks associated with the customers applications, adequate design and operating safeguards must be provided by the customer to minimize inherent or procedural hazards. For any safety concerns, contact NXP sales and technical support services.

Should this evaluation kit not meet the specifications indicated in the kit, it may be returned within 30 days from the date of delivery and will be replaced by a new kit.

NXP reserves the right to make changes without further notice to any products herein. NXP makes no warranty, representation or guarantee regarding the suitability of its products for any particular purpose, nor does NXP assume any liability arising out of the application or use of any product or circuit, and specifically disclaims any and all liability, including without limitation consequential or incidental damages. "Typical" parameters can and do vary in different applications and actual performance may vary over time. All operating parameters, including "Typical", must be validated for each customer application by customer's technical experts.

NXP does not convey any license under its patent rights nor the rights of others. NXP products are not designed, intended, or authorized for use as components in systems intended for surgical implant into the body, or other applications intended to support or sustain life, or for any other application in which the failure of the NXP product could create a situation where personal injury or death may occur.

Should the Buyer purchase or use NXP products for any such unintended or unauthorized application, the Buyer shall indemnify and hold NXP and its officers, employees, subsidiaries, affiliates, and distributors harmless against all claims, costs, damages, and expenses, and reasonable attorney fees arising out of, directly or indirectly, any claim of personal injury or death associated with such unintended or unauthorized use, even if such claim alleges NXP was negligent regarding the design or manufacture of the part.

2 Introduction

This document describes the PCA9957HN-ARD evaluation board. The evaluation board is built around the PCA9957HN, a 24-channel SPI serial bus 32 mA, 5.5 V constant current LED driver produced by NXP Semiconductors. The evaluation board serves as a daughter card that can be connected through an Arduino port to various Arduino compatible (including original Arduino Uno R3) EVK/mother boards for the purpose of testing and measuring the characteristics of the PCA9957HN Device Under Test (DUT).

The PCA9957HN host device communicates through the Arduino port with the LED driver via the high-speed SPI bus (up to 10 MHz clock frequency). The board is equipped with a pair of Fuji connectors that supports a SPI daisy chain scalable architecture. Thus, users can create a stack of similar boards that share the same SPI bus. The Fuji connectors are of the board-to-board type, allowing the user to attach the boards in a vertical stack instead of connecting link cables between the boards. Three additional digital lines in the SPI bus allow the mother board to control the DUT through the Arduino port or the Fuji connectors.

Power is delivered from the mother board (EVK) through the Arduino port. The power rails are shared with the Fuji connectors, so the DUT can be powered either from the Arduino connectors or the Fuji connectors.

The board contains four RGB LEDs and twelve white LEDs allocated to all twenty-four outputs of the PCA9957HN DUT. The board also contains jumpers and connectors that allow users to connect external LEDs to PCA9957HN outputs.

Additionally, a Graphical User Interface (Windows platform) is provided to facilitate the evaluation of the daughter board. The GUI is used in combination with the following NXP evaluation boards: IMXRT1050 EVK Board, LPCXpresso55S69 Development Board, and i.MX 8M Mini LPDDR4 EVK Board.

3 Finding Kit Resources and Information on the NXP Web Site

NXP Semiconductors provides online resources for this evaluation board and its supported device(s) at <http://www.nxp.com>.

The information page for the PCA9957HN-ARD evaluation board is at <http://www.nxp.com/PCA9957HN-ARD>. The information page provides overview information, documentation, software and tools, parametrics, ordering information and a **Getting Started** tab. The **Getting Started** tab provides quick-reference information applicable to using the PCA9957HN-ARD evaluation board, including the downloadable assets referenced in this document.

3.1 Collaborate in the NXP community

The NXP community is for sharing ideas and tips, ask and answer technical questions, and receive input on just about any embedded design topic.

The NXP community is at <http://community.nxp.com>.

4 Getting Ready

Working with the PCA9957HN-ARD requires the kit contents, additional hardware, and a Windows PC workstation with installed software.

4.1 Kit contents

- Assembled and tested evaluation board in an anti-static bag
- Quick Start Guide

4.2 Assumptions

Familiarity with the SPI bus is helpful but not required.

4.3 Static handling requirements

CAUTION



This device is sensitive to ElectroStatic Discharge (ESD). Therefore care should be taken during transport and handling. You must use a ground strap or touch the PC case or other grounded source before unpacking or handling the hardware.

4.4 Minimum system requirements

- PC with Windows 10 operating system
- One USB port (either 3.0 or 2.0 compatible)
- One of three EVKs boards mentioned in the previous section along with the associated firmware and GUI software
- USB cable for power and data connection between the PC and the EVK board (not included in the PCA9957HN-ARD daughter board package)

5 Getting to Know the Hardware

5.1 PCA9957HN-ARD features

- Combined Arduino port/Fuji connector for data and power
- Multiple board connection in stack architecture
- On-board LEDs for all 24 outputs of the DUT
- On-board jumpers for LED connection, and short tests
- On-board connectors for external LEDs
- Fully compliant with IMXRT1050 EVK board, including GUI (Windows 10)
- Fully compliant with LPCXpresso55S69 dev. board, including GUI (Windows 10)
- Compliant with i.MX Mini LPDDR4 EVK board, including GUI for Windows 10 (see Note 1)

Note 1: i.MX Mini LPDDR4 EVK Boards require the use of an IMX8MMINI-IARD interposer board between the EVK and PCA9957HN-ARDUINO daughter board (see IMX8MMINI-IARD User Manual) [here](#).

5.2 Block diagram

Figure 1 shows a block diagram of the PCA9957HN-ARD daughter board. The block diagram includes Arduino interface (J5, J6, J35, and J36 connectors) and the data lines connected to the port. The blue lines in the drawing refer to the SPI bus and the purple lines represents the control bus. The J46 and J47 connectors are Fuji connectors (see Section 5.8 "Fuji connectors"). J46 is the Fuji output connector (pin header) and is located on the top layer of the board. J46 is intended to be mated with a similar Fuji input connector (J47) on a board mounted directly on top of the first board. In this way, several boards can be connected in a stack. The first board is powered and communicates through the Arduino connector; the other attached boards draw power and communicate through the Fuji connectors.

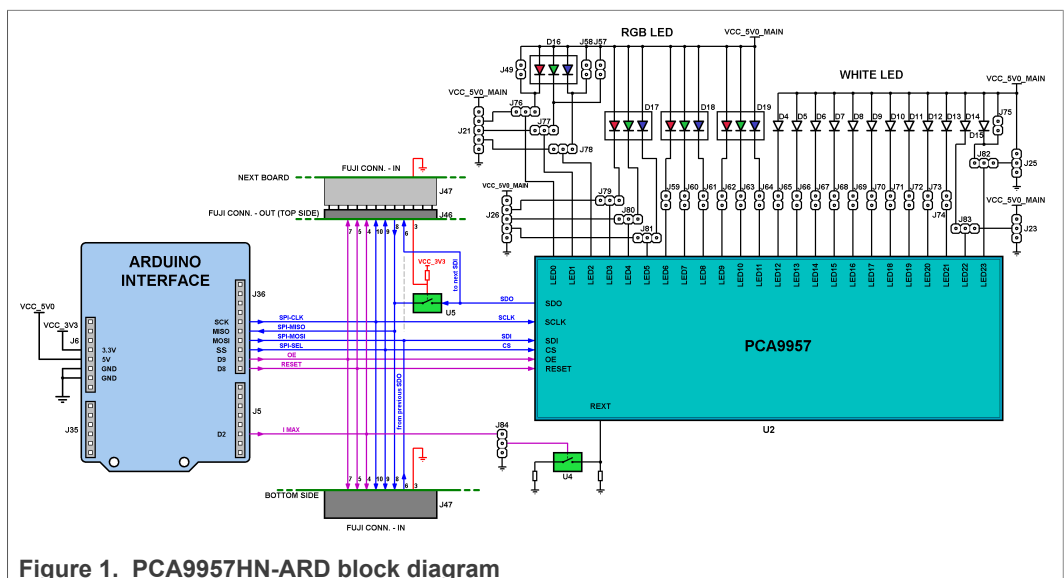

Figure 1. PCA9957HN-ARD block diagram

5.3 LED section

The PCA9957HN features twenty-four LED drivers (PWM controlled, current sink sources). Different LEDs are allocated to each output. The LEDs can be disconnected from the load with jumpers. Moreover, the RGB LED D16 has jumpers connected in parallel for short testing. The jumpers J76 to J81 allow the user to redirect the corresponding output lines of D16 and D17 RGB LEDs from the on-board LEDs to the RGB LED external connectors (J21 and J26). Using the connectors, the user can easily attach external LEDs for testing.

In the same manner, the corresponding line of white LEDs D14 and D15 can be redirected with J82 and J83 jumpers to white LED external connectors J23 and J25.

5.4 Power distribution

The power supply is provided from the EVK mother board for the first card, and through the Fuji connectors for all additional cards. There are two power rails: 3.3 V and 5 V. The main power consumption is from the 5 V power rail. The necessary current for one daughter board when all LEDs are turned on is 730 mA. Due to current limitations, the number of boards installed in the stack is limited. The limitation depends on the type of EVK being used and the current rating of the Arduino/Fuji connectors (approx. 4.5 A). The current limitation as a function of the EVK is as follows:

- IMXRT1050 EVK:
 - EVK powered from USB: limited by the current rating of the USB connector – max. 3 boards;
 - EVK powered from power barrel connector (J2): limited by power rating of Arduino / Fuji connectors – max. 5 boards;
- LPCXpresso55S69 EVK: limited by the current rating of the USB connector – max. 3 boards;
- i.MX LPDDR4 EVK: limited by the current delivered by the EVK power supply – max. 3 boards;

The on-board LED D2 is a 3.3 V rail indicator, and D3 is a 5 V rail indicator.

5.5 Control bus

The SPI bus contains three additional control lines (purple color in [Figure 1](#)): OE (Output Enable), RESET, and I MAX. OE and RESET are routed to the OE and RESET inputs of the DUT, directly from Arduino port for the first (or base daughter board) and through Fuji connectors for the additional boards (pin 5, and pin 7).

The I MAX line controls the switch U4. When U4 is open, the resistor R83 is connected between the REXT input of the PCA9957HN (pin 39) and ground. R83 sets the maximum current delivered at the outputs of the DUT at 20 mA. When U4 is closed, R79 is paralleled with R81 and the resulting maximum current increases to 30 mA. For more details regarding control lines, see the PCA9957 datasheet Table 1 and Table 2.

5.6 SPI bus

The SPI bus has a daisy chain architecture. When a single daughter board (inserted in the Arduino port) is used, the MISO line (J36, pin 4) goes from the Arduino port to the DUT SDI input (U2, pin 6). The signal is turned back from SDO (U2, pin 4) through the switch U5 (closed) to the MISO input of the Arduino port (J36, pin 5). U5 is closed

because the control input is pulled up (high state) through R89. When a secondary board is inserted into the Fuji output connector, the U5 control input located on the first board is pulled down to ground through pin 3 of J46 and J47 of the next board. When the switch U5 (first board) is open, the signal path of the SPI is: MOSI (Arduino port) – SDI input (U2, first board) – SDO output (U2, first board) – pin 6 (J46 first board) – pin 6 (J47 second board) – SDI (U2, second board) – SDO (U2, second board) – U5 (second board which is closed) – pin 8 (J47, second board – pin 8 (J46, first board) – MISO (Arduino port). The daisy chain loop is then closed through both DUT's on the two inter-connected daughter boards. The SPI clock and chip select lines are sent directly to the DUT (U2) on the first card, and through the Fuji connectors to the secondary card. For SPI characteristics and data format, see the PCA9957 datasheet Table 1 and Table 2, which details the pin map of the Arduino port and the Fuji connectors.

Note 2: For IMXRT1050 EVK, the SPI lines on the EVK board are not linked to the Arduino connector. Before using the EVK, the user must populate the DNP zero-ohm resistors R278 to R281 (see the EVK schematic diagram file SPF-30168_A1.pdf, available at www.nxp.com).

5.7 Arduino port

The connectors J5, J6, J35, and J36 are the mated pin headers of Arduino Uno R3 connectors, having the same electrical function and being placed on the board so that the daughter board can be directly inserted in the Arduino port. The daughter board circuit uses only seven signal lines. [Table 2](#) shows the Arduino connector pins and how they are used in the circuit (see also the SPF-46841.pdf schematic file).

Table 2. The pin chart of Arduino connectors and their usage

Note 3: A4 / SDA common line for J2 – 5 and J4 – 9. A5 / SCL common line for J2 – 6 and J4 – 10.

Ref Des	#	Arduino label	PCA9957HN-ARD function
J6 (Power)	1	NC	Not used
	2	IOREF	Not used
	3	RESET	Not used
	4	3.3V	Power supply
	5	5V	Not used
	6	GND	Power supply return
	7	GND	Power supply return
	8	Vin	Not used
J35 (analog, digital, I²C)	1	A0	Not used
	2	A1	Not used
	3	A2	Not used
	4	A3	Not used
	5	A4 / SDA ^(Note 2)	Not used
	6	A5 / SCL ^(Note 2)	Not used
J5 (digital, UART, PWM)	1	D0 / RX	Not used
	2	D1 / TX	Not used
	3	D2	REXT SELECT (SW_EN)

Table 2. The pin chart of Arduino connectors and their usage...continued

Note 3: A4 / SDA common line for J2 – 5 and J4 – 9. A5 / SCL common line for J2 – 6 and J4 – 10.

Ref Des	#	Arduino label	PCA9957HN-ARD function
	4	D3 / PWM	Not used
	5	D4	Not used
	6	D5 / PWM	Not used
	7	D6 / PWM	Not used
	8	D7	Not used
J36 (mixed)	1	D8	RESET (RESET_B_D8)
	2	D9 / PWM	OUTPUT ENABLE (OE_B_D9)
	3	D10 / SS / PWM	SPI – SELECT (SPI_C0_D10)
	4	D11 / MOSI / PWM	SPI – MOSI (SPI_MOSI_D11)
	5	D12 / MISO	SPI – MISO (SPI_MISO_D12)
	6	D13 / SCK	SPI – CLOCK (SPI_CLK)
	7	GND	Power supply return
	8	AREF	Not used
	9	A4 / SDA ^(Note 2)	Not used
	10	A5 / SCL ^(Note 2)	Not used

5.8 Fuji connectors

Fuji connectors J46 and J47 allow several PCA9957HN-ARD daughter boards to be configured in a stack architecture. The connector J46 is the Fuji output pin header placed on top of the layout. Fuji connector J46 is the pin receptacle located on the bottom of the layout. When two boards are connected, J47 of the secondary board is inserted into Fuji output connector (J46) of the primary (base) daughter board. [Table 3](#) shows the pin map of Fuji connectors and the function of the pins.

Table 3. The pin chart of Fuji connectors and their functions

J46	Fuji output connector (top)	J47	Fuji input connector (top)
1	3.3 V rail distribution	1	3.3 V rail distribution
2	5 V rail distribution	2	5 V rail distribution
3	Input control of switch U5	3	Connected to GND. Close the switch U5 of the previous board
4	I MAX (R EXT) control distribution	4	I MAX (R EXT) control distribution
5	RESET distribution	5	RESET distribution
6	SDO (U2) distribution to next board SDI (U2)	6	SDO (U2) from previous board
7	OE distribution	7	OE distribution
8	SDO (U2) from last Board to SPI-MISO	8	SDO (U2) from next board (SDO bridge)
9	SPI – CS distribution	9	SPI – CS distribution
10	SPI – CLOCK distribution	10	SPI – CLOCK distribution
11	GND	11	GND
12	GND	12	GND

5.9 Not populated components

In the schematic diagram / board layout some components are not soldered on the board. Crystal X1 is one of the main DNP (Do Not Populate) components. X1 is missing because the project is designed to accommodate two DUTs from the same LED driver series (PCA9957, and PCA9959). However, only one of the DUTs—PCA9959—needs a crystal oscillator to work properly. Since the PCA9957HN does not require an external oscillator, the X1 crystal and the associated passive components were not soldered on the board. The capacitors C3 and C4 also are not necessary in the circuit, therefore they are not populated.

5.10 Board layout and component placement

Figure 2 shows the top silkscreen of the board and Figure 3 shows a PCA9957HN-ARD daughter card, top side (up) and bottom side (down). The pictures allow users to quickly find the location of the the board components involved in test and measurement evaluations. The main elements of the board are called out in the picture. The Arduino port connectors (J5, J6, J35, J36) are located on the bottom side of the board.

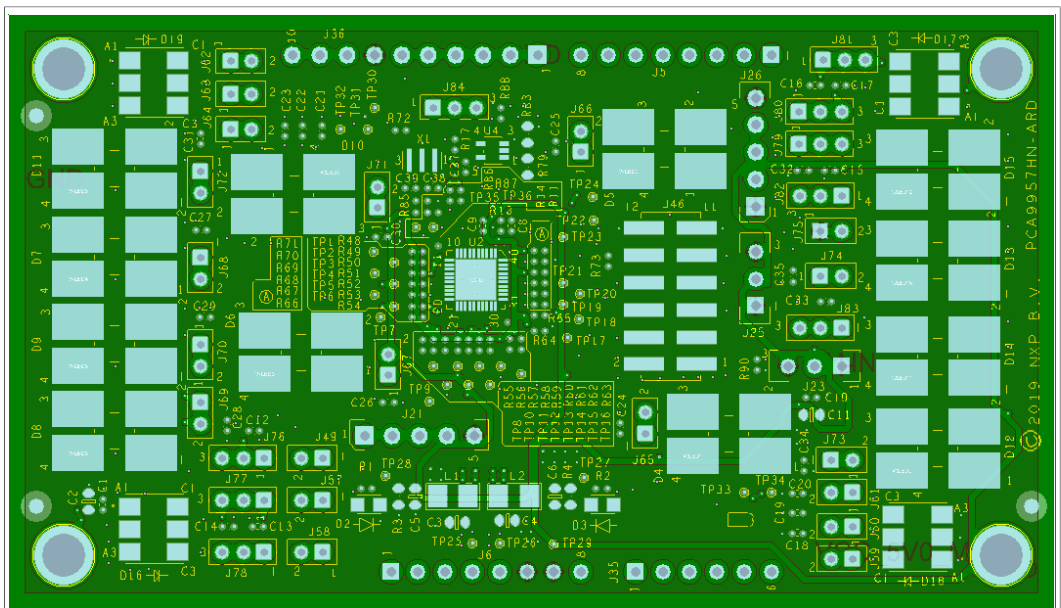

Figure 2. The PCA9957HN-ARD silkscreen (top view)

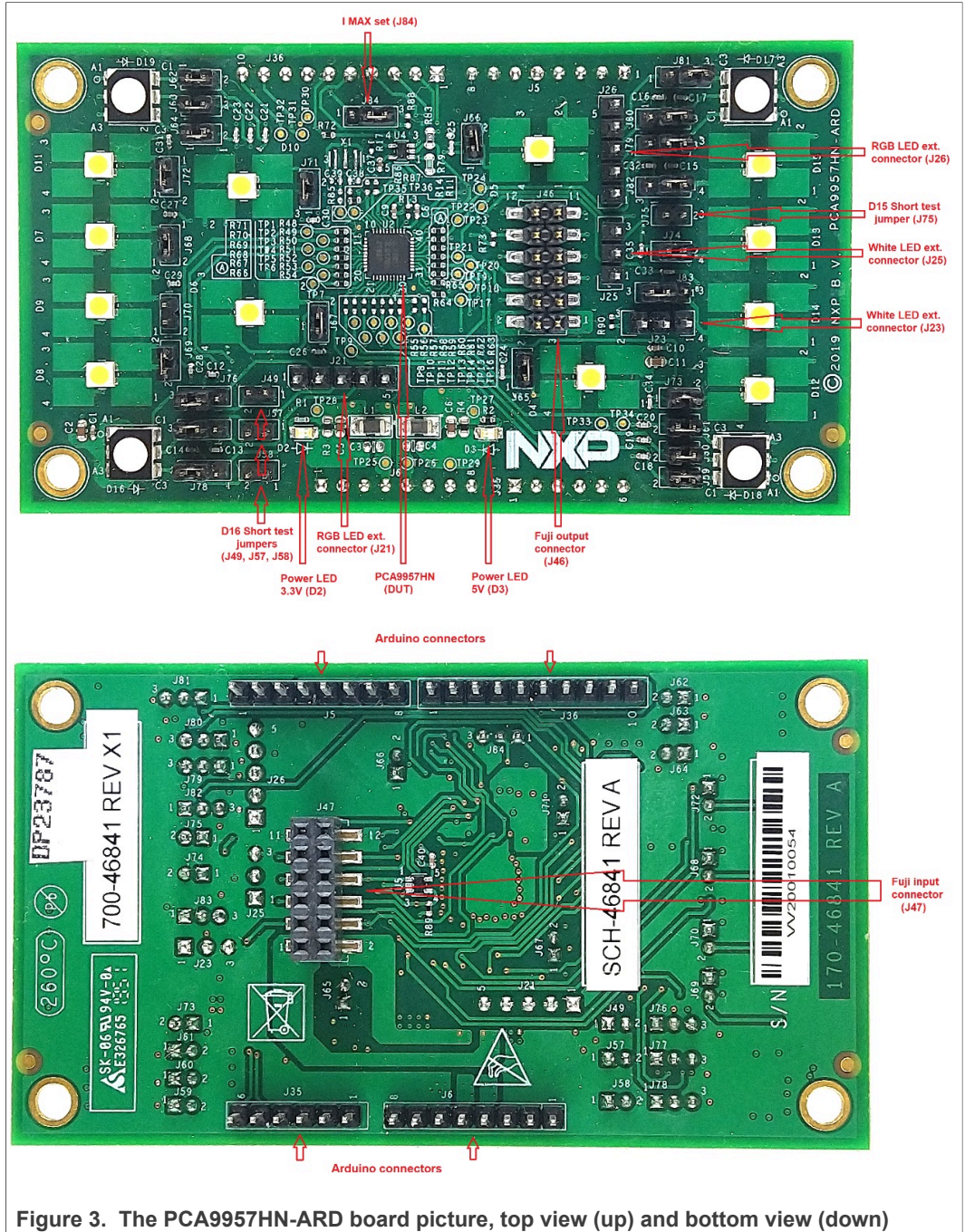

Figure 3. The PCA9957HN-ARD board picture, top view (up) and bottom view (down)

6 Installing and Configuring Software Tools

PCA9957HN_ARD evaluation board is designed and built as a daughter board able to work in conjunction with a mother board equipped with an Arduino port. The board was built to be fully compatible with the following NXP Evaluation (EVK) boards:

- IMXRT1050 EVK Board;
- LPCXpresso55S69 Development Board;
- i.MX 8M Mini LPDDR4 EVK Board;

Each of the above evaluation/development boards is supported by firmware that can be downloaded from the NXP site (www.nxp.com/). Before beginning to use a paired EVK – PCA9957HN-ARD configuration, the EVK motherboard must be programmed with the corresponding firmware package. Additionally, a GUI application (Windows 10) is available for download from the NXP site, allowing rapid testing and operation of the PCA9957HN-ARD daughter board in conjunction with the EVK. The GUI application is common for all three EVKs and for the PCA9xxx LED Controller development card family, manufactured by NXP (PCA9957, PCA9959, and PCA9955B ICs). For details regarding installation of the EVK firmware and GUI host software on PC, download [EVK_Firmware_And_GUI_Install_Guide_For_Arduino_Boards.pdf](#) instruction file from NXP site (www.nxp.com). Once the software is installed, the first step is to select the correct EVK from the graphical interface. The board can then be controlled from the GUI interface. See [Section 7 "Configuring the Hardware"](#) and [Section 8 "GUI Description"](#) for more details on using the GUI software to operate the PCA9957HN-ARD.

7 Configuring the Hardware

7.1 Using the PCA9957HN-ARD with an IMXRT1050 EVK board

Figure 4 shows the required hardware for operation of the PCA9957HN-ARD daughter board with IMXRT1050 EVK.

- One IMXRT1050 EVK board
- One PCA9957HN-ARD daughter board
- One USB-A/USB Micro-B cable
- A PC with Windows 10 operating system

The IMXRT1050 EVK mother board can be powered by one of the following three methods:

- Connecting an external 5 VDC power supply to the barrel power connector (J2) on the board
- Connecting a USB cable from the PC to the the Micro-B USB connector (J9) on the board
- Connecting a USB cable from the PC to the USB connector (J28) on the board. When the PC is connected in this fashion, the USB port can simultaneously act as a debug interface. Therefore, by using a single USB cable connected to J28, the EVK can be powered and at the same time linked to the PC for data exchange.

Be aware that older USB ports (USB 1.1) might not be able to deliver the 500 mA current needed before establishing communication. If the PC has USB 1.1 or earlier ports, an external power supply must be connected to J2 on the IMXRT1050 EVK.

From J1 on the EVK board (see Figure 4) the user can select the power configuration for the mother board. For further details, download the IMXRT1050 EVK Board Hardware User Guide (IMXRT1050EVKHUG.pdf) available [here](#).

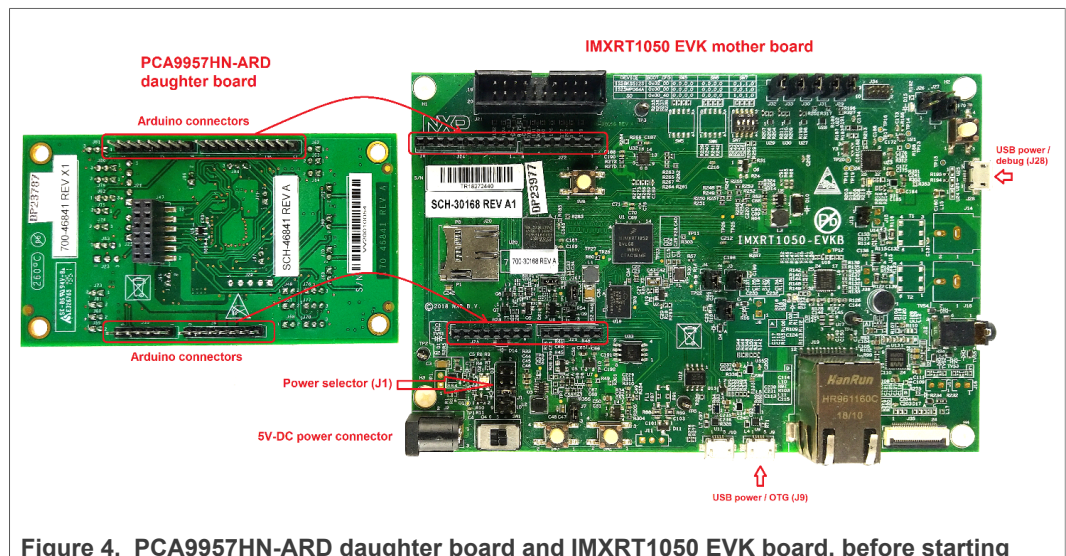

Figure 4. PCA9957HN-ARD daughter board and IMXRT1050 EVK board, before starting

Once the hardware is available and assuming the PC USB port can deliver the required power for the EVK, follow the steps below to install and operate the boards:

1. On the IMXRT1050 EVK board, populate R278, R279, R280, R281 with zero-ohm resistors (0402 package) to link the SPI lines to the Arduino connector (see Note 2 in [Section 5.6 "SPI bus"](#)).
2. Using jumper J1, select the suitable power configuration for the EVK.
 - To select USB J28 as the power supply, place a jumper in the 5–6 position on jumper J1.
 - To select an external power supply connected to the barrel power connector J2, place a jumper in position 1–2 on jumper J1.
3. Insert the PCA9957HN-ARD daughter card into the Arduino connector on the EVK. (See [Figure 4](#).)
4. Using USB connector J28, connect the EVK board to a USB port on the computer.
5. Install the IMXRT1050 target firmware. (Download the firmware from the NXP site [here](#) and read the EVK_Firmware_And_GUI_Install_Guide_For_Arduino_Boards.pdf instruction file.)
6. Install the GUI application on the PC. (See the instruction file called out in the previous step.)
7. Open the GUI application to operate the device from the PC. For details regarding GUI operation, see [Section 8 "GUI Description"](#).

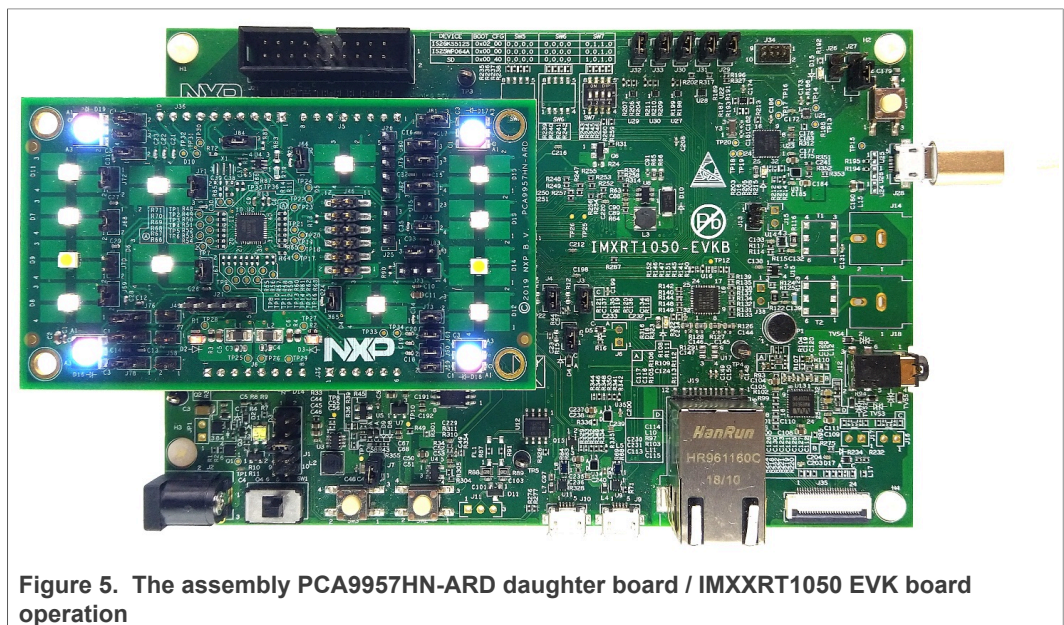

Figure 5. The assembly PCA9957HN-ARD daughter board / IMXRT1050 EVK board operation

7.2 Using the PCA9957HN-ARD with an LPCXpresso55S69 development board

[Figure 6](#) shows the necessary hardware involved when using the PCA9957HN-ARD board with an LPCXpresso55S69 board. This configuration consists of:

- One LPCXpresso55S69 development board
- One PCA9957HN-ARD daughter board
- One USB-A/USB Micro-B cable
- A PC with Windows 10 operating system

The LPCXpresso55S69 development board is equipped with four USB Micro-B connectors: P5, P6, P9 and P10. The board can be powered through any USB port.

However, using the P6 USB connector to connect the board to the PC simplifies the start-up operation because P6 is designated for debugging and the USB cable thus accomplishes two tasks at the same time: powering the board and serving as a data link between the EVK board and PC. For more details regarding power-up and operation of the LPCXpresso55S69 development board, see the *LPCXpresso55S69/LPCXpresso55S28 Development Board User Manual* [here](#).

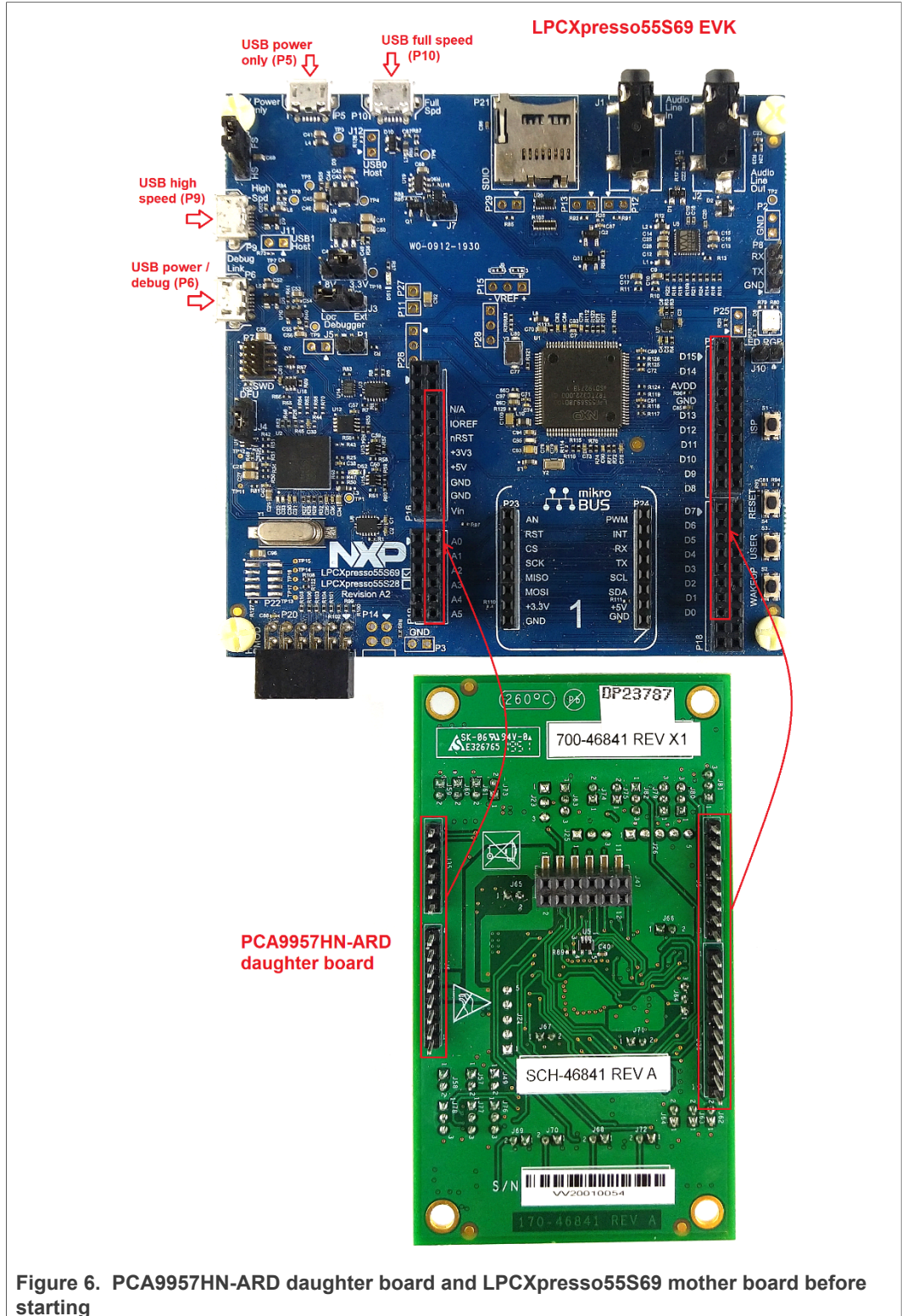

Figure 6. PCA9957HN-ARD daughter board and LPCXpresso55S69 mother board before starting

The following steps describe how to assemble, power up, program, and operate the configuration shown in [Figure 6](#)

1. Insert the PCA9957HN-ARD daughter card to P16 – P19 connectors located on LPCXpresso55S69 development board (see the marked pins of P16 – P19, [Figure 6](#));

2. Connect the development board using port P6 USB port of PC.
3. Install the LPCXpresso55S69 target firmware (download from the NXP site [here](#) and read the *EVK_Firmware_And_GUI_Install_Guide_For_Arduino_Boards.pdf* instruction file);
4. Install GUI application on PC (see the instruction file called out in the previous step).
5. Open the GUI application to operate the device from the PC. For details regarding GUI operation see [Section 8 "GUI Description"](#).

Figure 7 shows the two boards in operation.

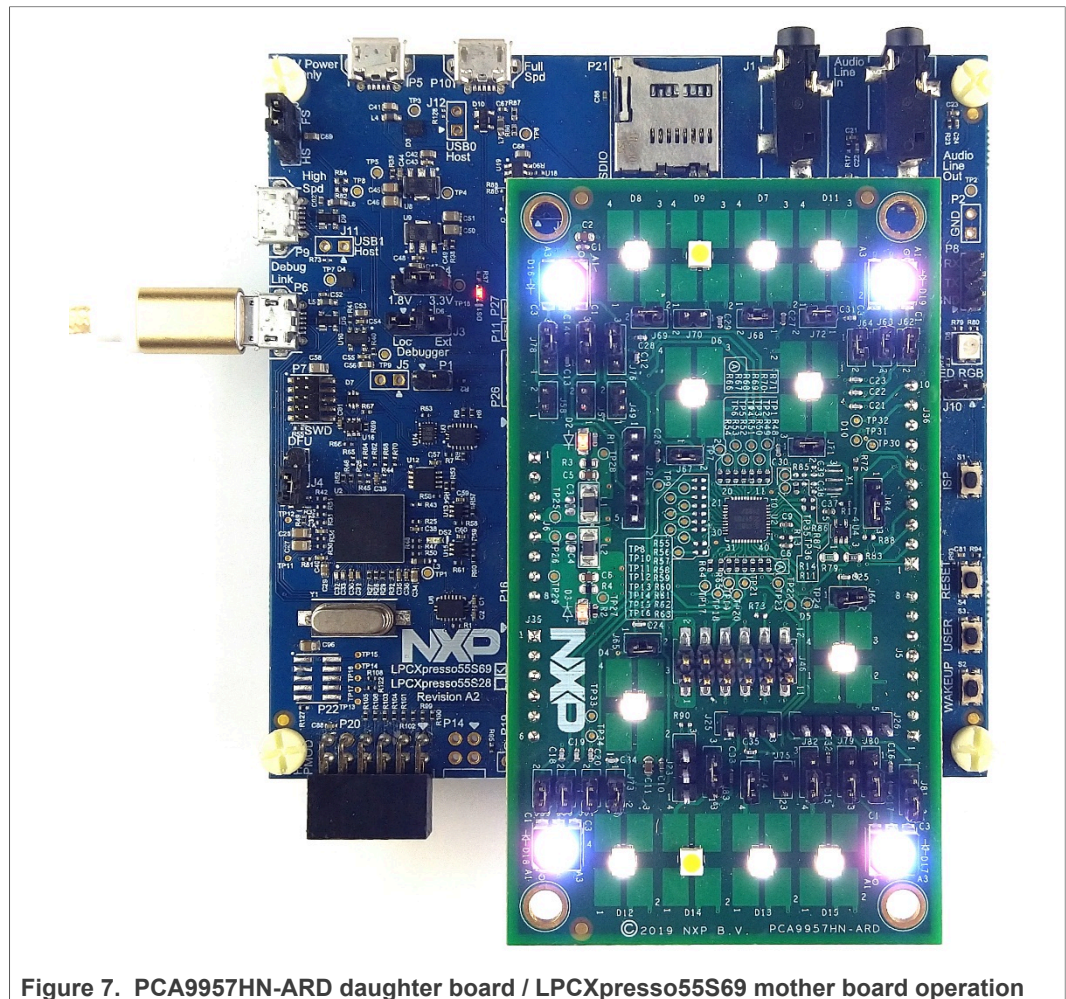

Figure 7. PCA9957HN-ARD daughter board / LPCXpresso55S69 mother board operation

7.3 Using the PCA9957HN-ARD with an i.MX 8M Mini LPDDR4 EVK board

When an i.MX 8M Mini LPDDR4 EVK board is used with the PCA9957HN-ARD board, a specially designed EVK daughter board—the IMX8MMINI-IARD board—must be mounted as an interposer between the i.MX 8M Mini EVK board and the PCA957HN-ARD. This is because the i.MX 8M Mini LPDDR4 uses a 2 x 20-pin expansion connector (J1003) instead of an Arduino connector.

Connector J1003 on the i.MX 8M Mini LPDDR4 EVK board is a multipurpose port containing digital I/O lines, including specialized I²C and SPI buses. The IMX8MMINI-IARD interposer serves as a signal-to-signal bridge between the Arduino connector

pins on the PCA9957HD-ARD board and the 2 x 20 connector pins on the i.MX 8M Mini LPDDR4 EVK board.

Figure 8 shows how these three boards are connected. This configuration consists of:

- One i.MX 8M Mini LPDDR4 EVK board
- One PCA9957HN-ARD board
- One IMX8MMINI-IARD interposer board
- One USB-C cable
- One USB Micro-B cable

To power-up and operate the setup, the USB-C cable for power must be connected to PORT 2 of the EVK board. The power switch SW101 on the EVK board must be set to the ON position to power-up the setup. Data communication is achieved by routing a USB Micro-B cable from a USB port on the PC to the debug port (J901) on the EVK. Attach the daughter board by plugging the PCA9957HN-ARD board into the Arduino connector of the IMX8MMINI-IARD interposer and then plugging the IMX8MMINI-IARD interposer into the expansion connector (J1003) located on the i.MX8MMINI EVK board. (See Figure 8 for the location of all referenced connectors and switches.)

For more details regarding the power-up and operation of the setup assembly, see *i.MX 8M Mini LPDDR4 EVK Board Hardware User's Guide* (IMX8MMEVKHUG.pdf), available [here](#), and IMX8MMINI-IARD User Manual (UM46675.pdf) documents, available [here](#).

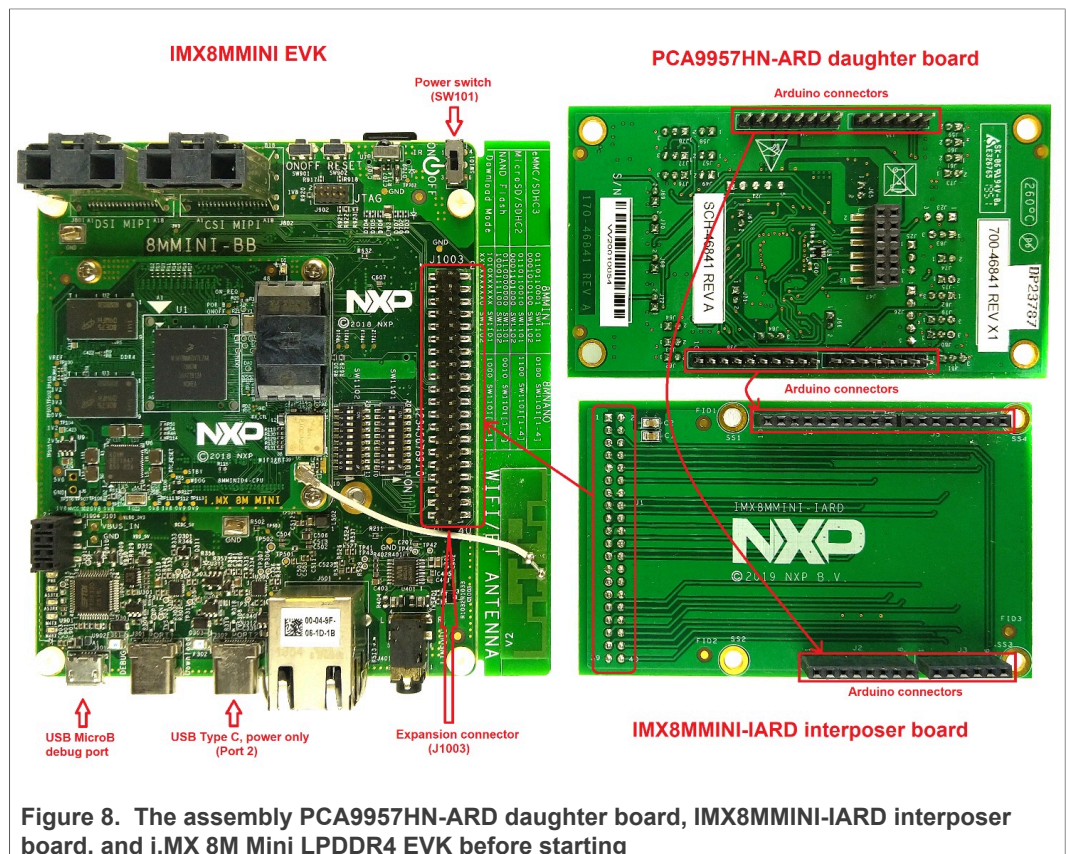

Figure 8. The assembly PCA9957HN-ARD daughter board, IMX8MMINI-IARD interposer board, and i.MX 8M Mini LPDDR4 EVK before starting

Follow the below steps to install, program and operate the setup assembly consisting of the PCA9957HN-ARD daughter board, IMX8MMINI-IARD interposer board, and i.MX 8M Mini LPDDR4 EVK board:

1. Insert the PCA9957HN-ARD onto the IMX8MMINI-IARD interposer board Arduino connectors (located on the top side).
2. Attach IMX8MMINI-IARD connector J1 (located on the bottom of the board) into J1003 expansion board located on the top side of i.MX 8M Mini LPDDR4 EVK (see [Figure 8](#)).
3. Power-up the EVK board using a USB Type C cable attached to Port 2.
4. Connect the EVK to the PC using a USB Micro-B cable attached to J901 debug port.
5. Place SW101 in the ON position to power-up the boards.
6. Install the MIMXRT1050 target firmware (download the [EVK_Firmware_And_GUI_Install_Guide_For_Arduino_Boards.pdf](#) instruction file [here](#)).
7. Install the GUI application on the PC (see the instruction file referenced in the above step).
8. Open the GUI application to operate the device from the PC. For details regarding GUI operation, see [Section 8 "GUI Description"](#).

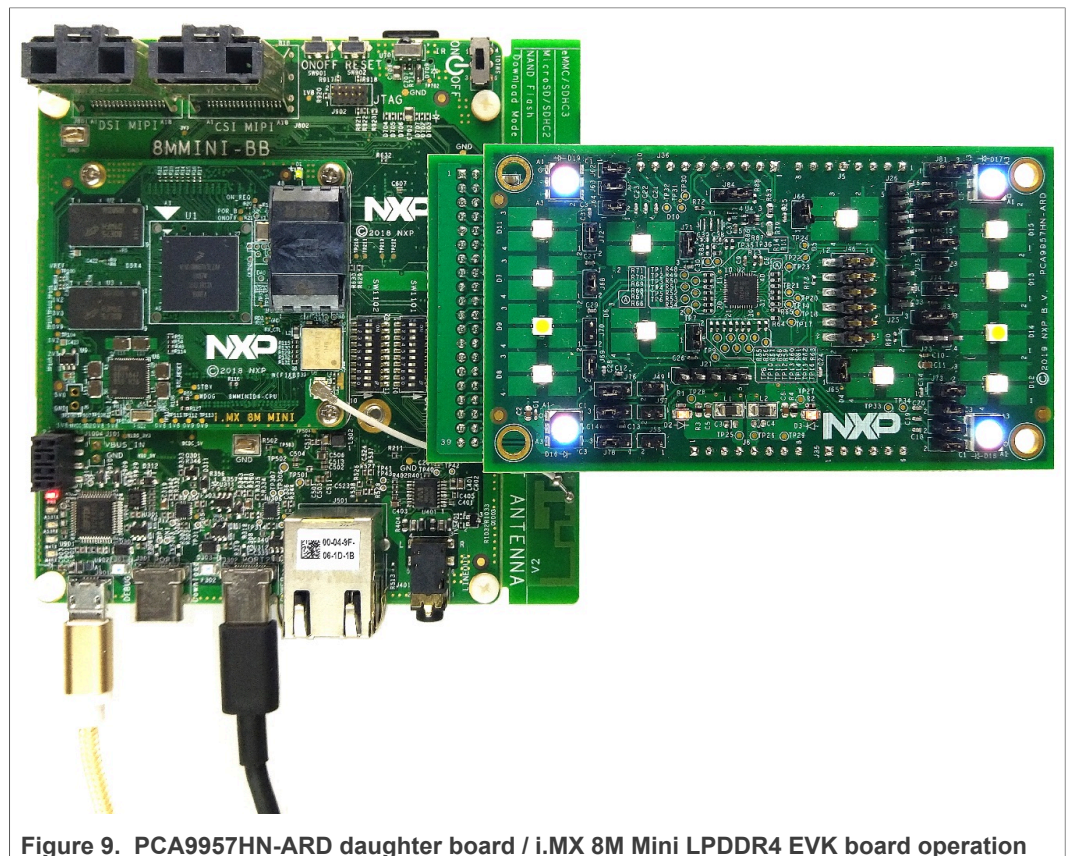

Figure 9. PCA9957HN-ARD daughter board / i.MX 8M Mini LPDDR4 EVK board operation

8 GUI Description

A GUI application is available for the three EVK boards from NXP Semiconductors. The application is common for all EVKs/development boards.

This section describes the GUI application and how the user can control the PCA9957HN-ARD daughter board from the graphical interface: First, install the GUI package and software package downloaded from the NXP site ([here](#)) on the PC (Windows 10). For more installation details, download and read EVK_Firmware_And_GUI_Install_Guide_For_Arduino_Boards.pdf instruction file from the NXP site ([here](#)). Once installation is complete, assure that one of the three supported EVKs with the attached PCA9957HN-ARD daughter board is connected to the PC and powered-on. Open the NXP_GUI(PCA995x) GUI application. An interface will appear as is shown in [Figure 10](#)

8.1 Settings

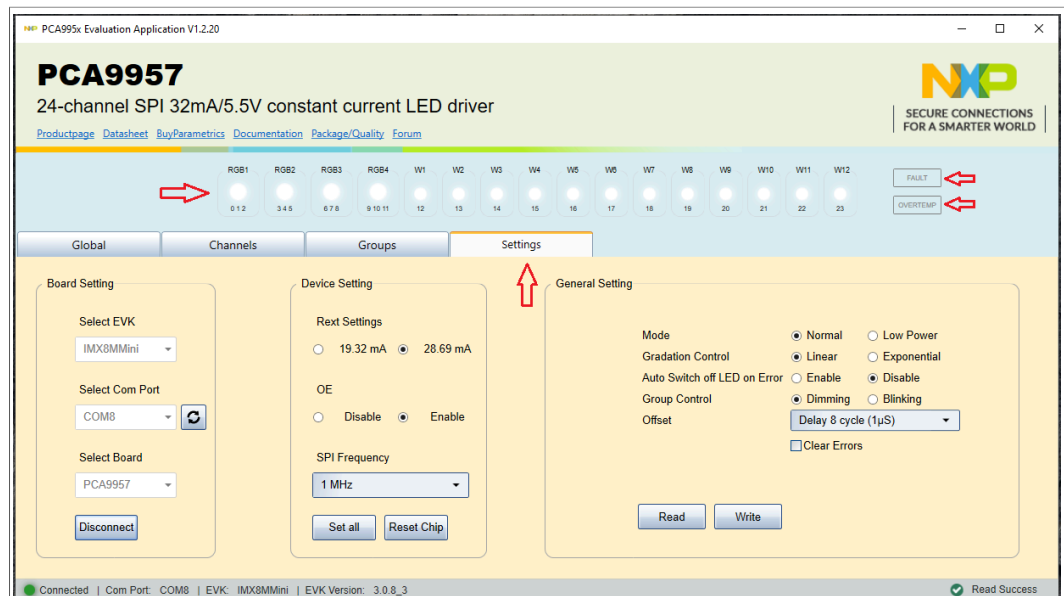

Figure 10. Graphical user interface — Settings tab activated

The GUI application starts with the **Settings** tab (marked with red arrow). The blue region at the top contains indicators that display the status of each of the LEDs located on the PCA9957HN-ARD daughter board (marked with the red arrow.) To the left of the LED indicators are two read-only flags (also marked with a red arrow) mapped to the MODE2 register (#01h). The **FAULT** flag indicates that the PCA9957HN-ARD's internal controller has detected an LED output error (no load, short). The **OVERTEMP** flag indicates that the PCA997HD-ARD die temperature exceeds its specified limit. (See the “LED error detection” and “Overtemperature protection” sections in PCA9957 datasheet.)

Below the LED indicators are three sections: **General Setting** on the right, **Device Setting** in the middle, and **Board Setting** on the left.

Board Setting parameters are:

- **Select EVK** displays a list of EVKs. Selecting a wrong EVK board causes the connection to fail and a pop-up window with the message: “Unable to Connect with EVK” appears on the screen.

- **Select COM Port** displays the port selected for the communication. The port is automatically selected by the system and is shown here as (**COM8**).
- **Select Board** allows the user to select the correct daughter board (the application can support three different boards). In [Figure 10](#) the selected board is **PCA9957**.

Click Connect, to establish the connection with the EVK. Selecting the wrong EVK or daughter board, causes the connection to fail and a pop-up window with the message: "Unable to Connect with Daughter Card" appears on the screen.

Device Setting parameters are:

- **REXT Settings** selects the maximum current delivered by the LED drivers. This selection is determined by the status of switch U4 on the PCA9957HN-ARD board (See [Section 5 "Getting to Know the Hardware"](#))
OE controls the OE input of the DUT.
- **SPI Frequency** selects the bus speed. The drop-down box allows the selection of four values: 100 kHz, 1 MHz (default value), 4 MHz, and 10 MHz.

Clicking the **Set All** button at the bottom of the section causes the selected values to be set in the daughter board. Clicking **Reset Chip** returns the DUT's internal registers to their default values.

The PCA9957 device's internal controller has seventy-two 8-bit registers that provide detailed control (i.e. output current, PWM control, gradation control, blinking or dimming mode, etc.), working modes, and error management. These registers are organized into a register map (see PCA9957 datasheet, Table 4). In order to avoid conflicts that might force the PCA9957 into an unknown state, some register values are prohibited. All register constraints are detailed in the IC datasheet. The GUI application reflects the PCA9957 register map, but the GUI doesn't comprehend the register constraints. (Although, messages at the bottom of some GUI windows help the user avoid some of the constraints.) Therefore, the user must fully understand the internal register map of the PCA9957 device (see note 5). Note that violating one or more of the register constraints will not damage the PCA9957, and the internal registers can be returned to their default values by clicking the **Reset Chip** button. The PCA9957 datasheet (PCA9957DS.pdf) is available [here](#).

General Settings

The displayed parameters in the section, belongs to internal registers MODE1, MODE2, and OFFSET (#00h, #01h, and #69h).

The bottom side of the GUI, displays a status bar showing the connection status between PC and the EVK

Note 5: Due to high complexity of the internal register map and functions of PCA9957HN IC, for proper operation and testing of the daughter board from GUI application, the user should read in detail the PCA9957 data sheet [here](#).

8.2 Global

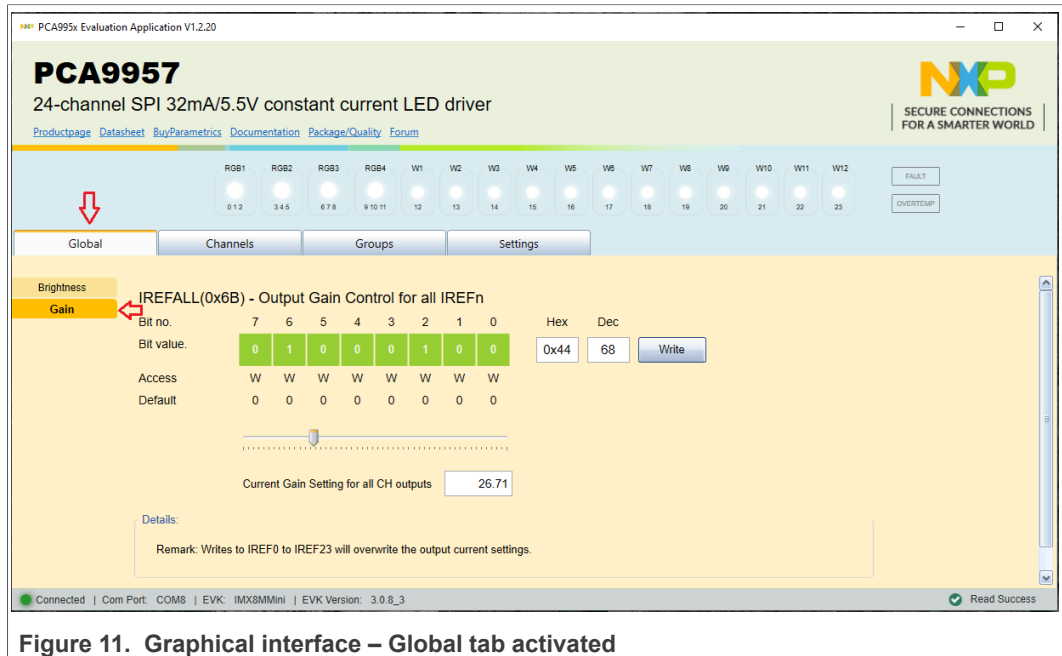

Figure 11. Graphical interface – Global tab activated

The Global tab contains two secondary tabs: **Brightness** and **Gain** (marked with a red arrow)

Brightness

Global LED brightness is determined by bit settings in the PWMALL register (#6Ah). The **Global** tab allows the PWMALL register value to be changed by the GUI. The **Brightness** tab opens with default values for the register. Register values can be changed by toggling the green boxes that represent individual register bits or by directly entering the new value in the **Hex** or **Dec** text box. The changes take affect when the **Write** button is clicked.

Gain

Output gain is determined by bit settings in the IREFALL register (#6Bh). The **Gain** tab (depicted in [Figure 11](#)) allows the IREFALL register value to be changed by the GUI. Register values can be changed by toggling the green boxes that represent individual register bits or by directly entering the new value in the **Hex** or **Dec** text box. The changes take affect when the **Write** button is clicked.

8.3 Channels

Activating the **Channels** tab brings up the display shown in [Figure 12](#). The red arrows show the main tab and the default secondary **Brightness** tab. [Table 4](#) shows the names and HEX addresses of all the secondary tabs registers available under the **Channels** main tab. The registers can be set individually with **Write** button or globally by clicking the **WriteAll** button. The **Read** button loads data from the registers into the GUI.

Table 4. Secondary tabs under Channels

Tab	Picture in	Register name	Register HEX	Remarks
Brightness	Figure 12	PWMx	#27h	Read / Write / Write All

Table 4. Secondary tabs under Channels...continued

Tab	Picture in	Register name	Register HEX	Remarks
Gain	Figure 13	IREF _x	#3Fh	Read / Write / Write All
Output	Figure 14	CHOUT _x	#0Dh	Read / Write / Write All
Gradation	Figure 15	GRADMODE_SEL _x	#58h, #59h, #6Ah	Read / Write / Write All
Errors	Figure 16	EFLAG _x	#02h - #07h	Read

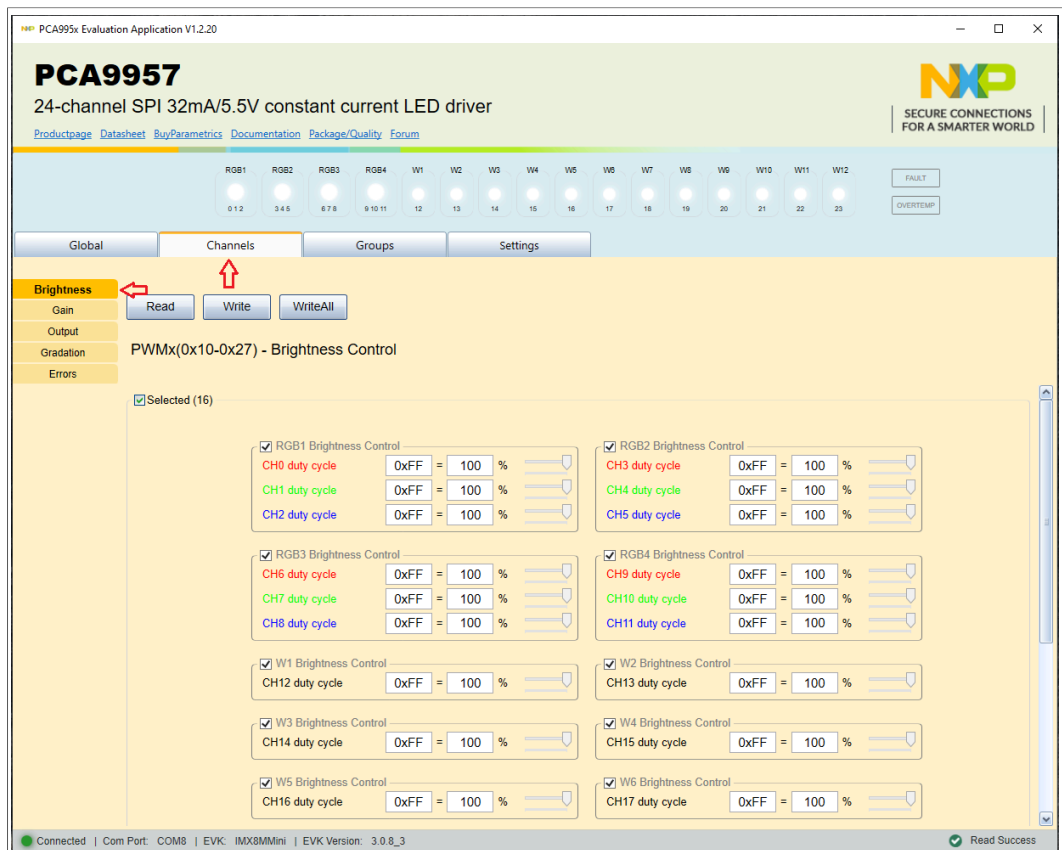

Figure 12. Graphical interface – Channels / Brightness tab activated

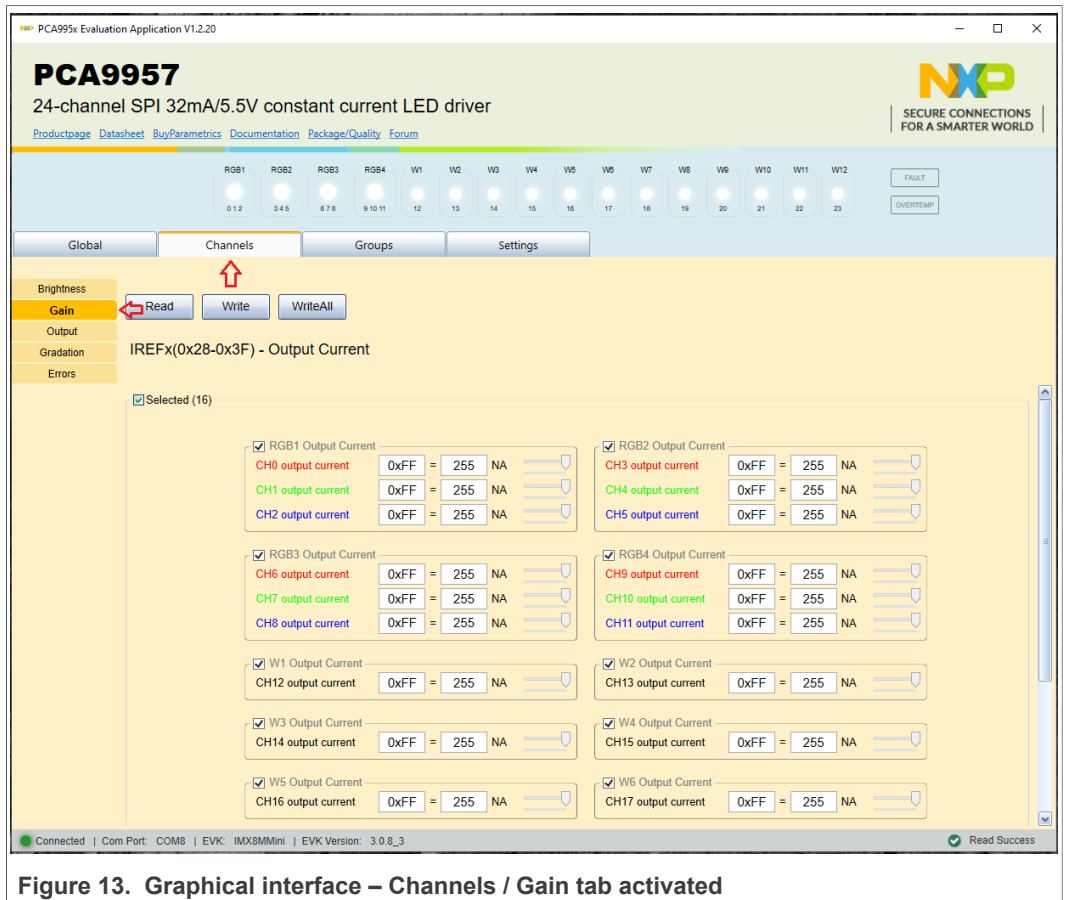

Figure 13. Graphical interface – Channels / Gain tab activated

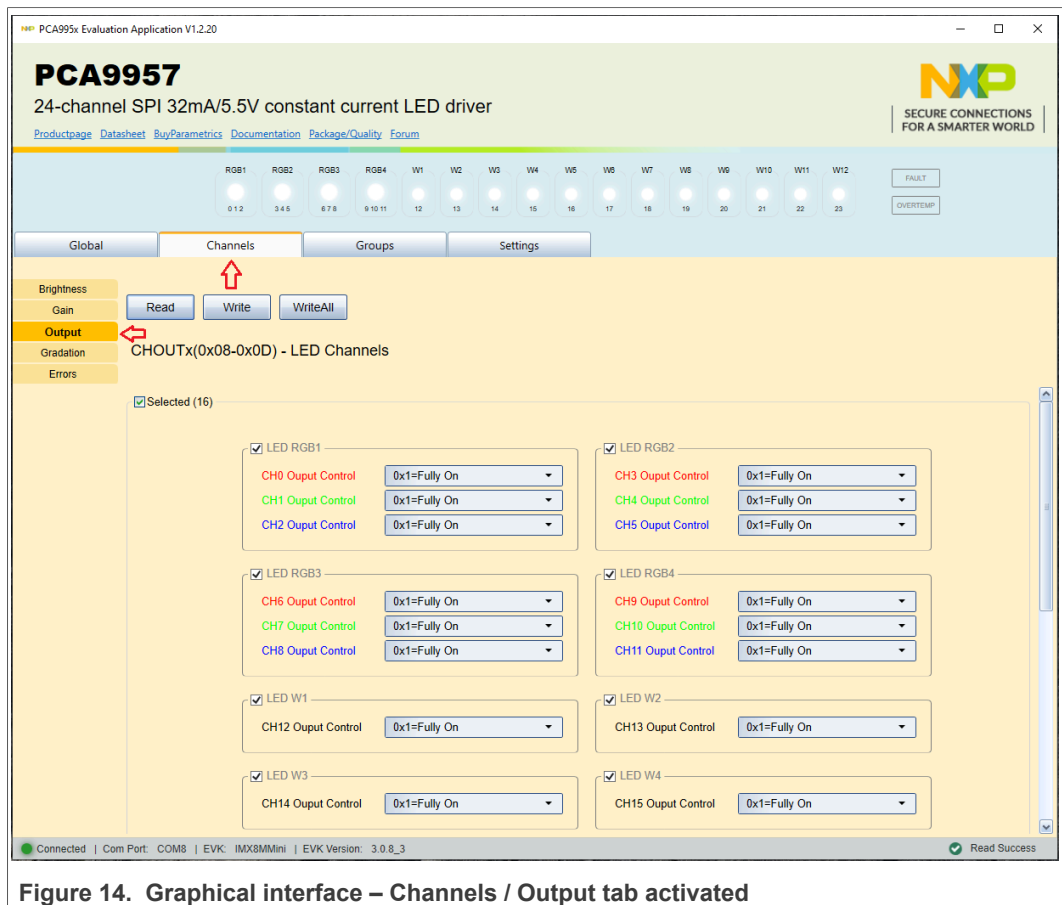

Figure 14. Graphical interface – Channels / Output tab activated

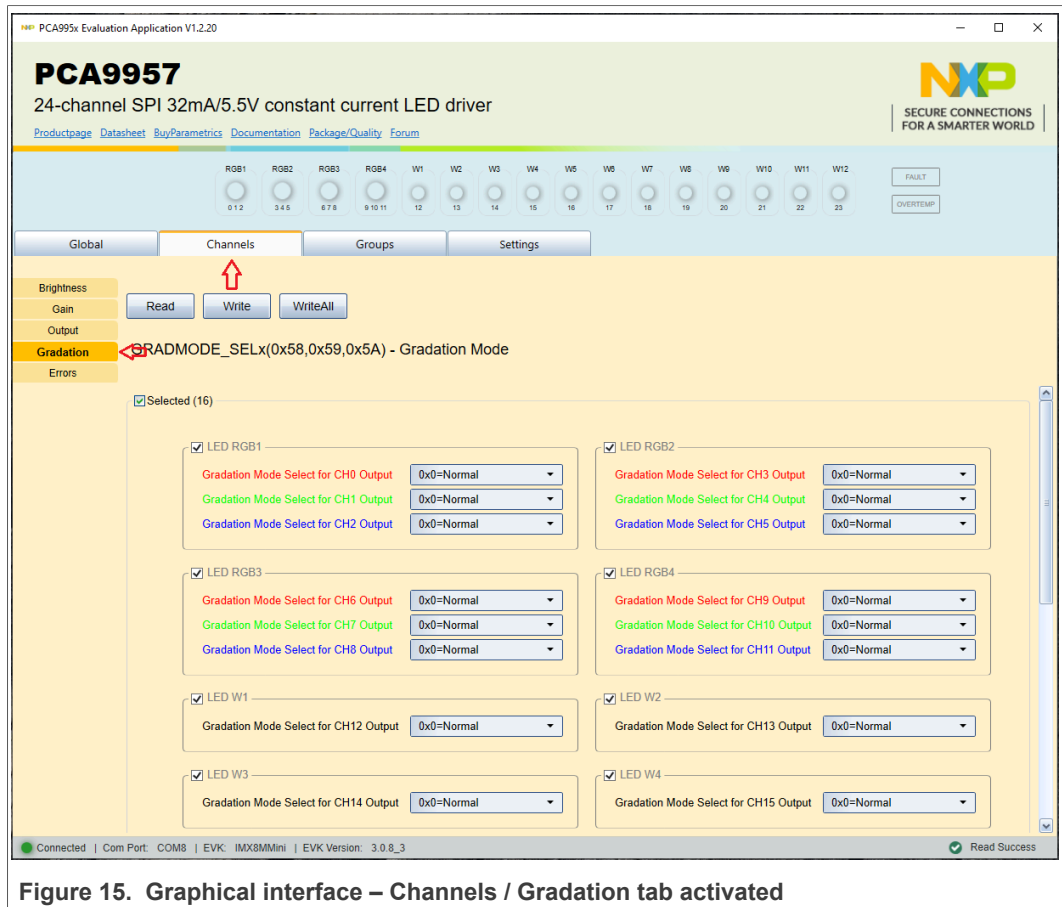

Figure 15. Graphical interface – Channels / Gradation tab activated

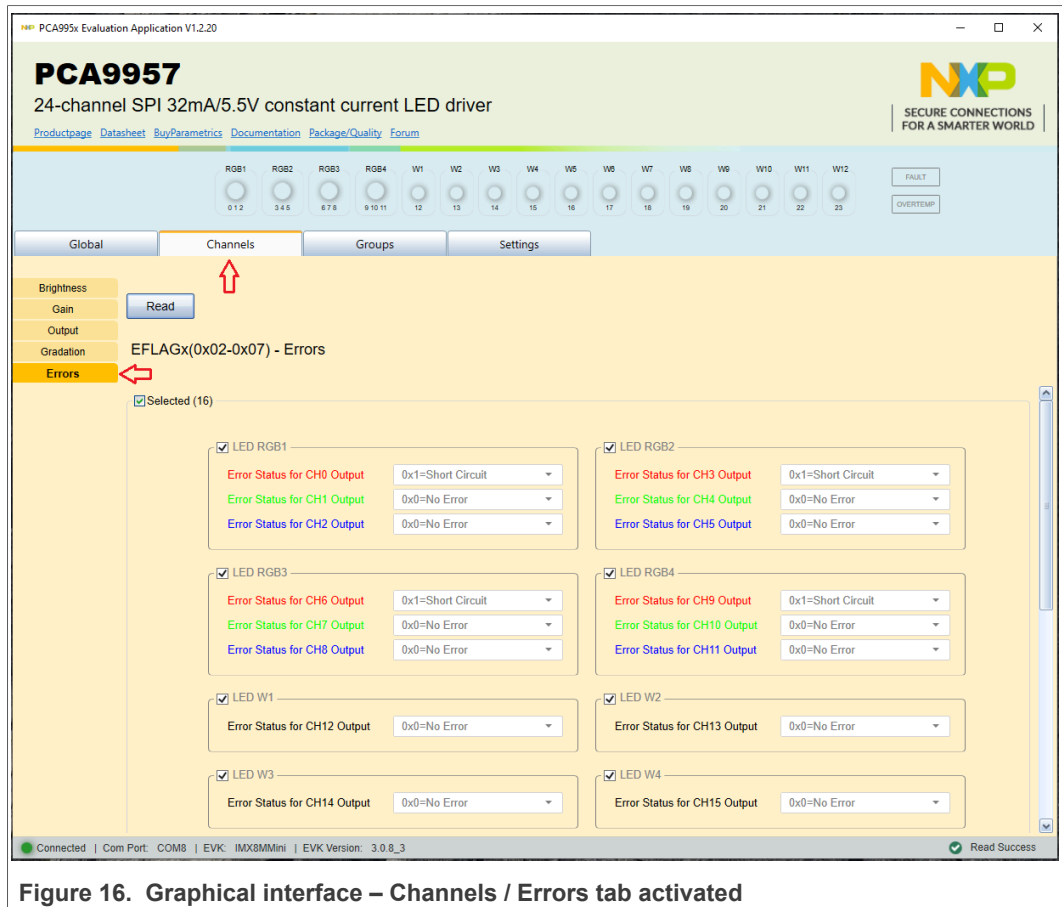

Figure 16. Graphical interface – Channels / Errors tab activated

8.4 Groups

Activating the **Groups** tab brings up the display shown in [Figure 17](#). The red arrows show the main tab and the default secondary **Brightness** tab. [Table 5](#) shows the names and HEX addresses of all the secondary tab registers available under the **Channels** main tab. The registers can be set individually with **Write** button or globally by clicking the **WriteAll** button. The **Read** button loads data from the registers into the GUI.

Table 5. Secondary tabs under Groups

Tab	Picture in	Register name	Register HEX	Remarks
Brightness	Figure 17	GRPPWM	#0Eh	Read / Write
Blink	Figure 18	GRPFREQ	#0Fh	Read / Write
Gain	Figure 19	IREFGRP _x	#43h, #47h, #4Bh, #4Fh, #53h, #57h	Read / Write
Ramping	Figure 20	RAMPRATE_GRP _x	#40h, #44h, #48h, #4Ch, #50h, #54h	Read / Write
Step time	Figure 21	STEPTIME_GRP _x	#41h, #45h, #49h, #4Dh, #51h, #55h	Read / Write
Hold	Figure 22	HOLDCNTL_GRP _x	#42h, #46h, #4Ah, #4Eh, #53h, #56h	Read / Write
Gradation	Figure 23	GRADCNTL	#67h, #68h	Read / Write
Define	Figure 24	GRADGRP_SEL _x	#5Bh, #66h	Read / Write / Write All

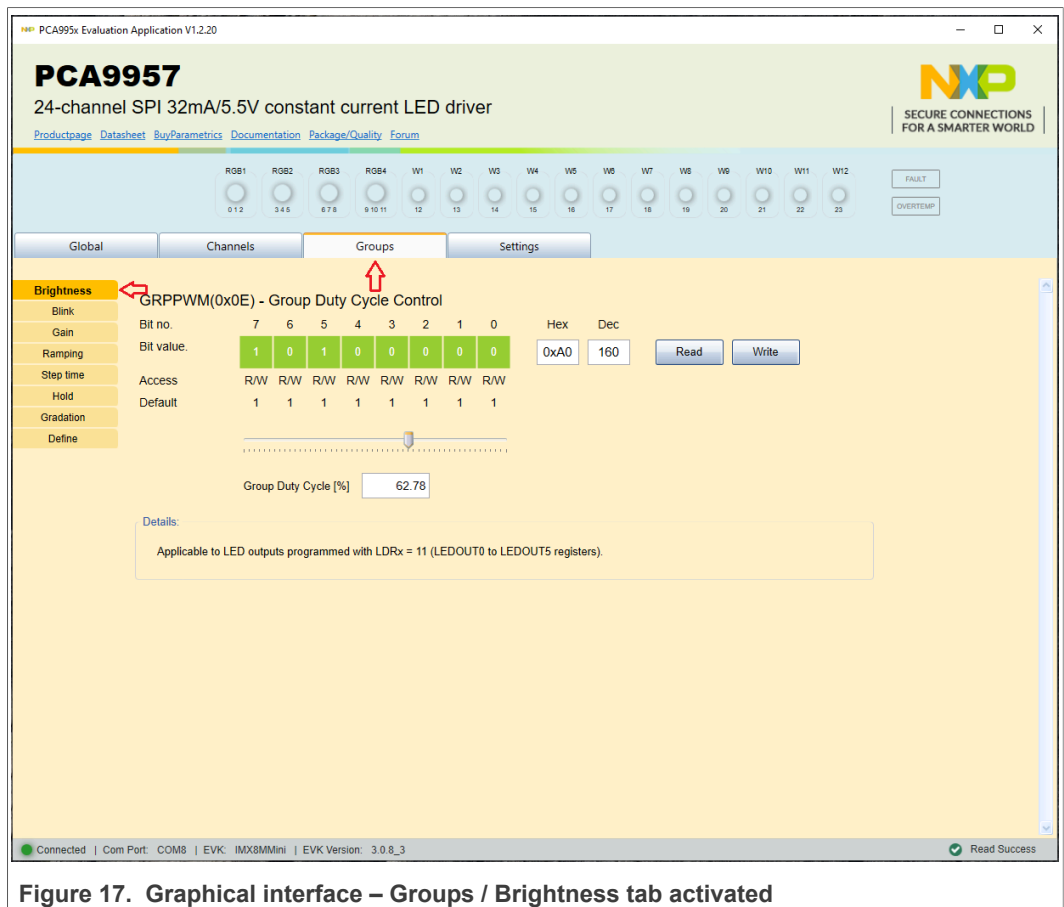
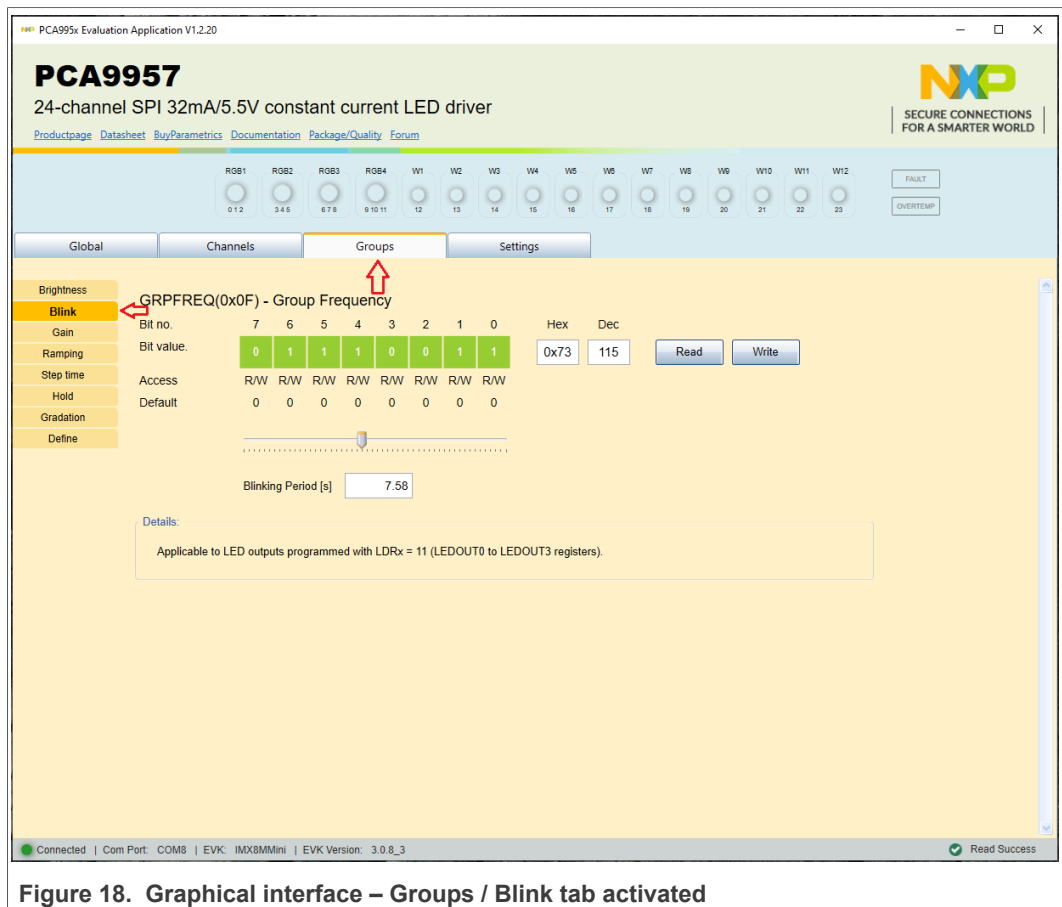

Figure 17. Graphical interface – Groups / Brightness tab activated



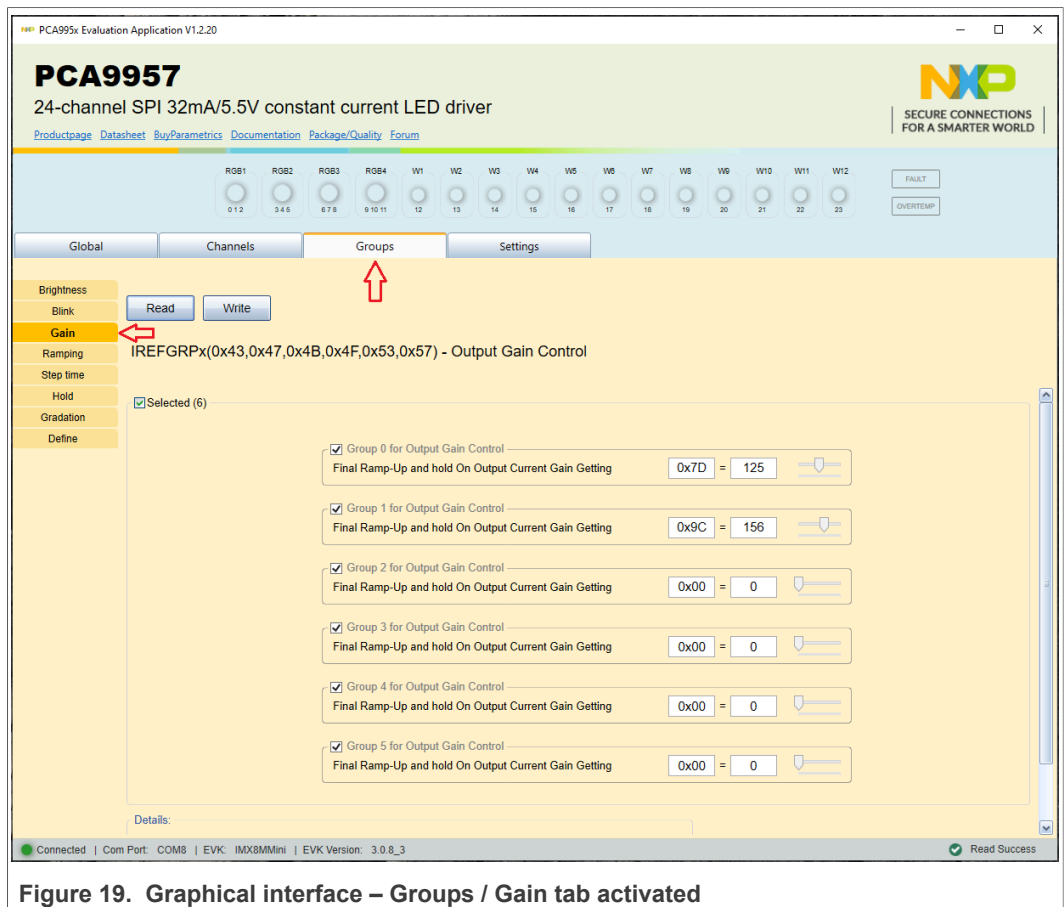

Figure 19. Graphical interface – Groups / Gain tab activated

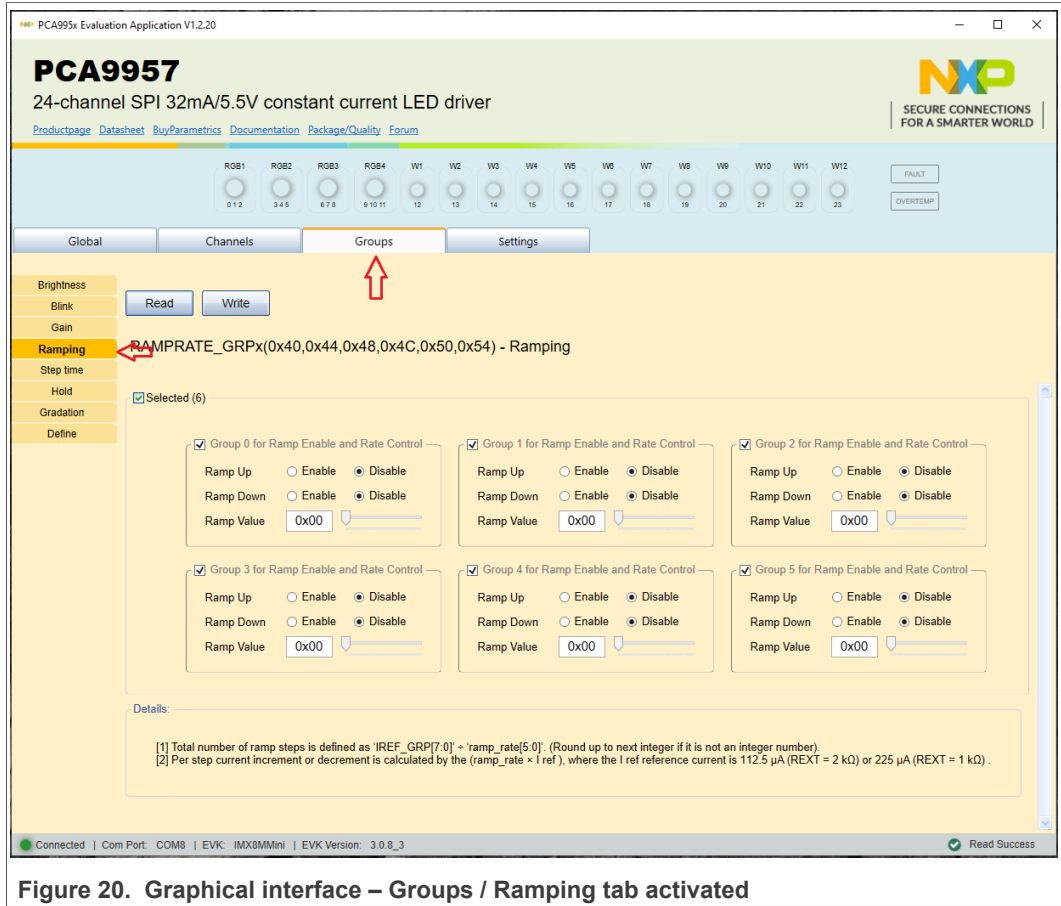

Figure 20. Graphical interface – Groups / Ramping tab activated

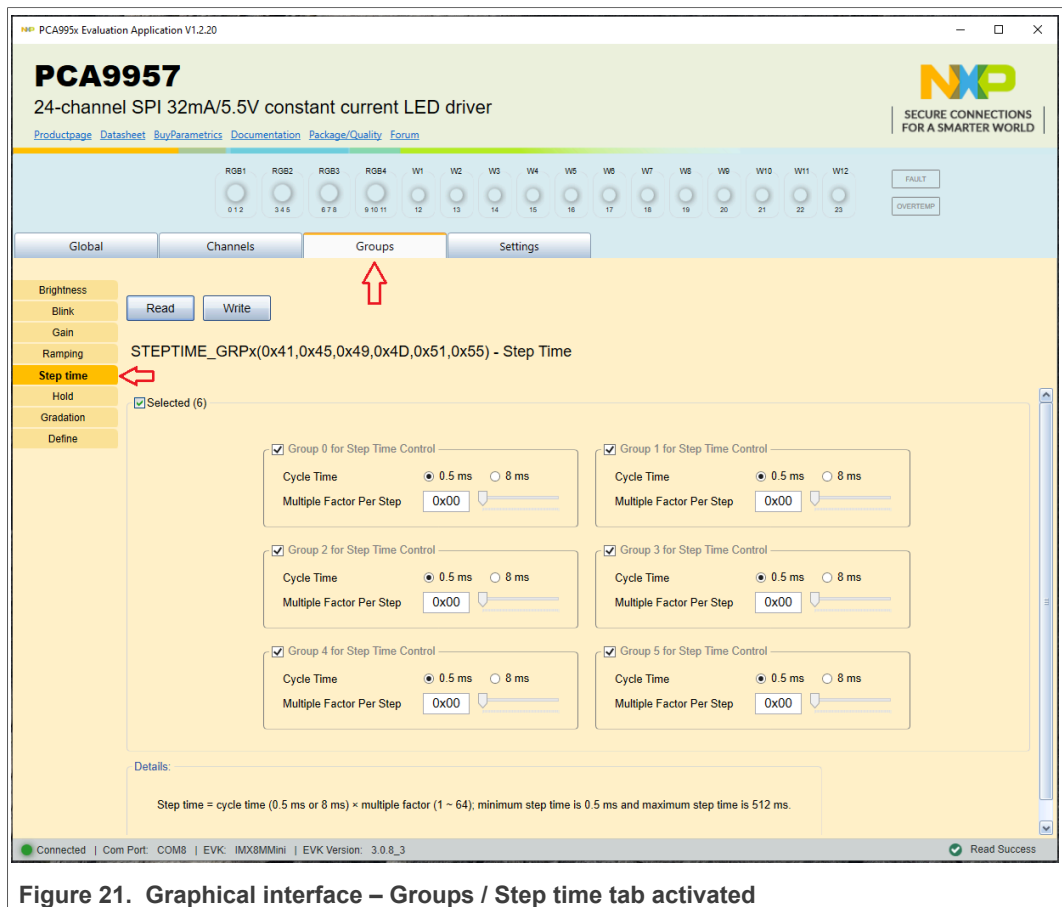

Figure 21. Graphical interface – Groups / Step time tab activated

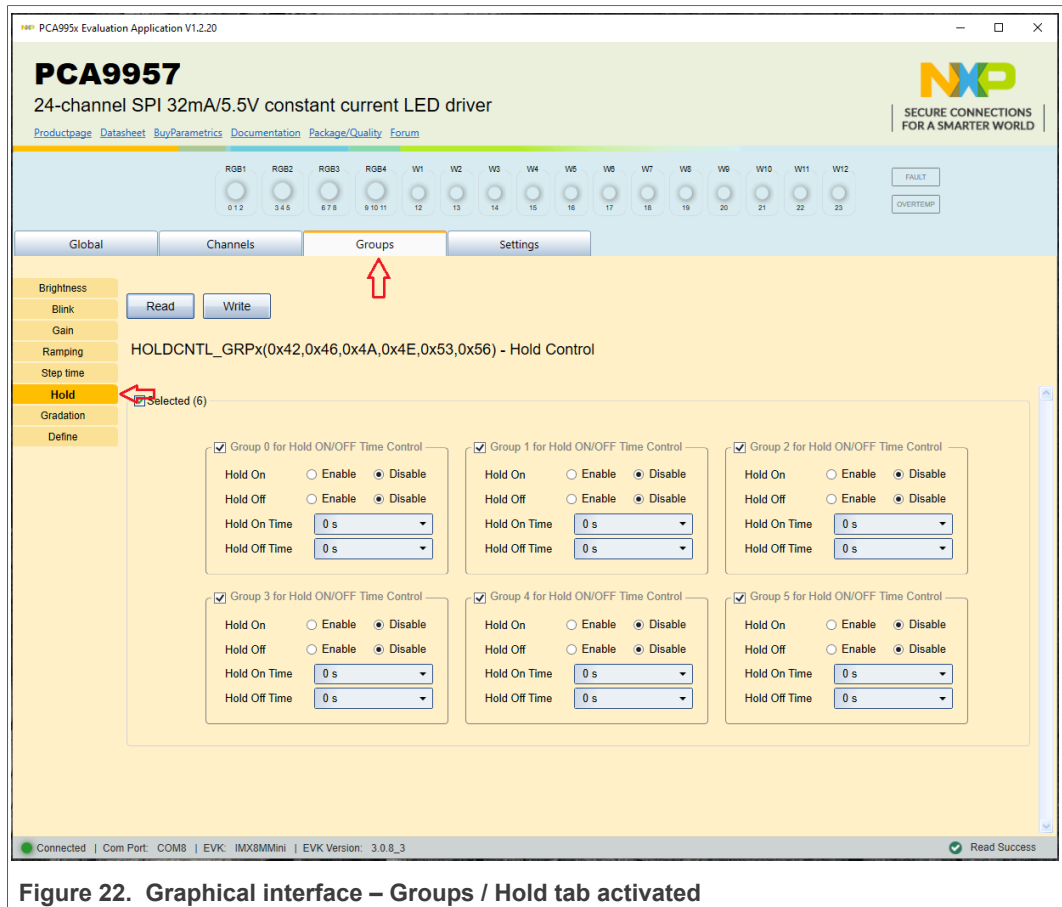

Figure 22. Graphical interface – Groups / Hold tab activated

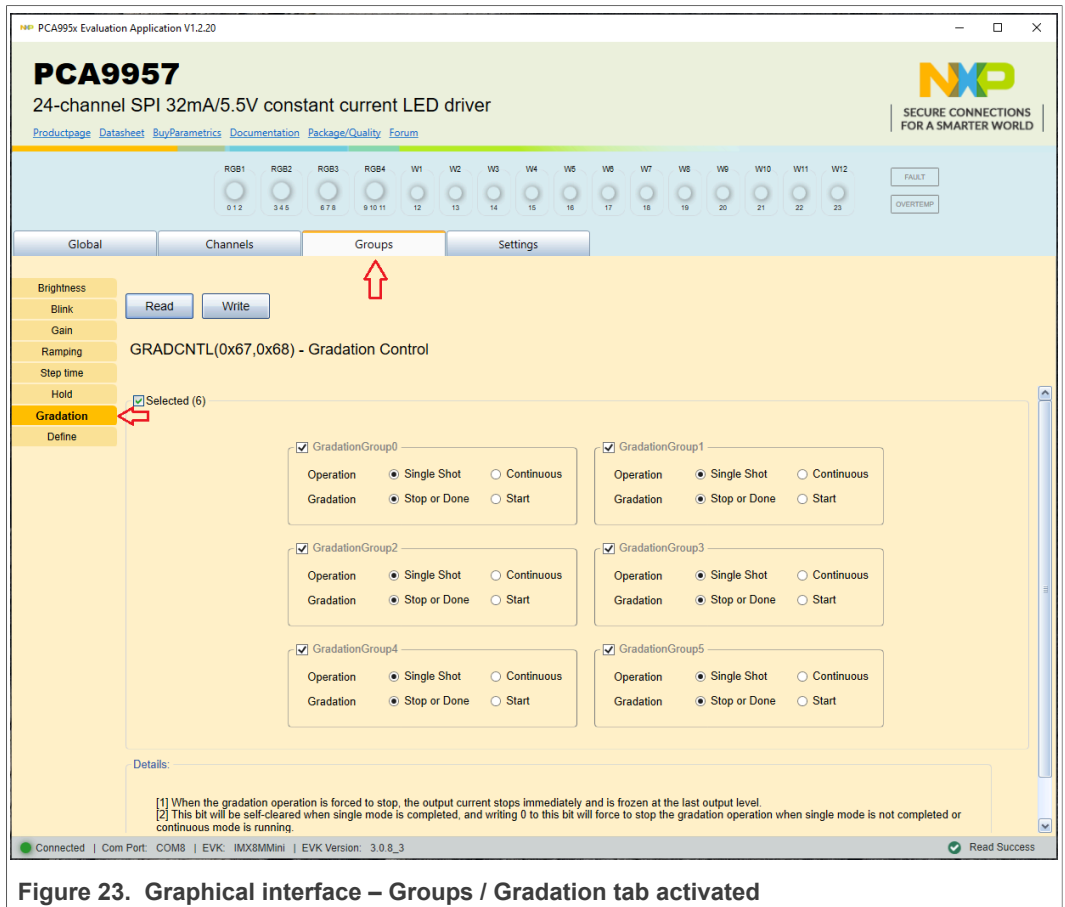

Figure 23. Graphical interface – Groups / Gradation tab activated

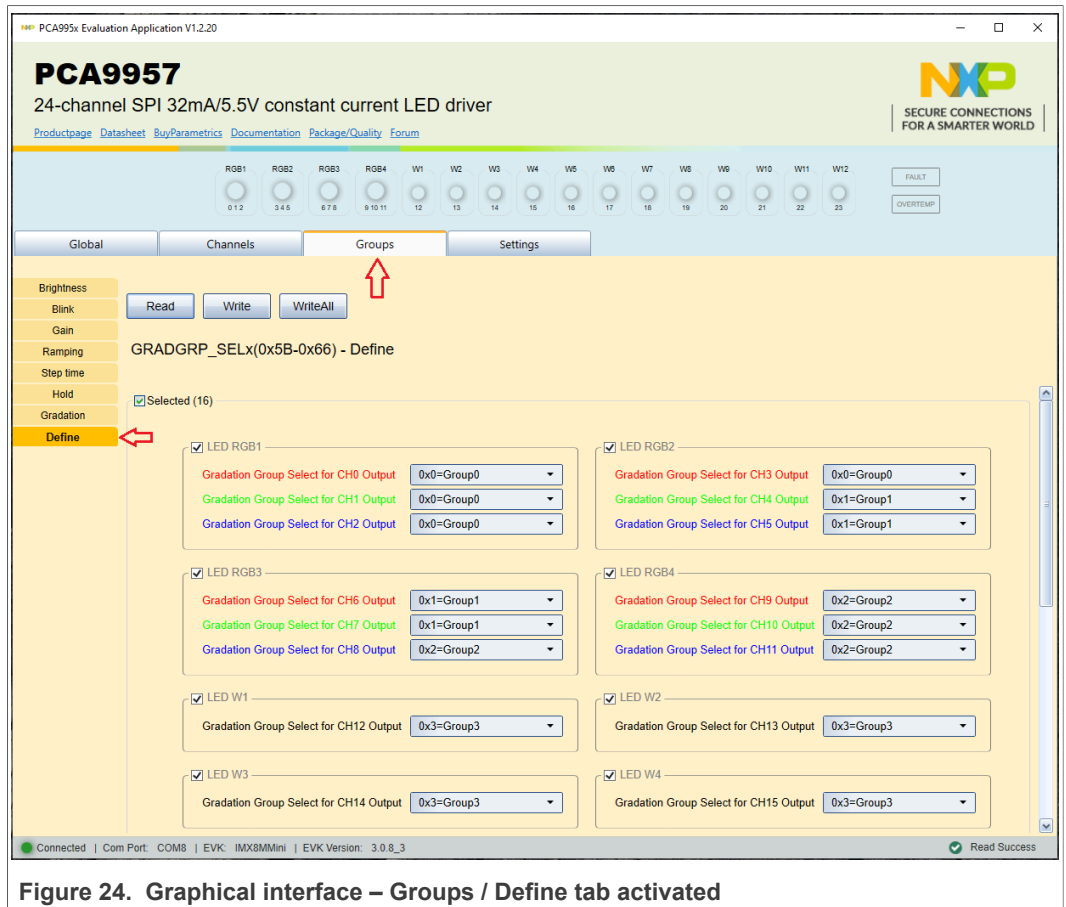

Figure 24. Graphical interface – Groups / Define tab activated

9 Abbreviations

Table 6. Abbreviations

Acronym	Description
DNP	Do Not Populate
DUT	Device Under Test
ESD	Electro Static Discharge
EVK	Evaluation Board
GUI	Graphical User Interface
I ² C bus	Inter-Integrated Circuit bus
IC	Integrated Circuit
LED	Light Emitting Diode
OS	Overtemp Shutdown
PC	Personal Computer
SPI	Serial Peripheral Interface
USB	Universal Serial Bus

10 References

- [1] [PCA9957, 24-channel SPI serial bus 32 mA / 5.5 V constant current LED driver – Rev. 1 – 24 October 2019](#)
- [2] [MIMxrt1050 EVK Board Hardware User's Guide](#)
- [3] [i.MX RT1050 Crossover Processors Data Sheet for Consumer Products](#)
- [4] [UM11158 – LPCXpresso55S69 Development Board](#)
- [5] [LPC556x Data Sheet](#)
- [6] [i.MX 8M Mini LPDDR4 EVK Board Hardware User's Guide](#)
- [7] [i.MX 8M Mini Application Processor Datasheet for Consumer Products](#)
- [8] [i.MX 8M Mini Application Processor Reference Manual](#)
- [9] [Arduino Uno R3 Reference Manual](#)
- [10] [iMX8MMINI-IARD interposer board User Manual](#)
- [11] [NXP EVK Firmware and GUI Installation Guide for Arduino Series Boards](#)

11 Legal information

11.1 Definitions

Draft — A draft status on a document indicates that the content is still under internal review and subject to formal approval, which may result in modifications or additions. NXP Semiconductors does not give any representations or warranties as to the accuracy or completeness of information included in a draft version of a document and shall have no liability for the consequences of use of such information.

11.2 Disclaimers

Limited warranty and liability — Information in this document is believed to be accurate and reliable. However, NXP Semiconductors does not give any representations or warranties, expressed or implied, as to the accuracy or completeness of such information and shall have no liability for the consequences of use of such information. NXP Semiconductors takes no responsibility for the content in this document if provided by an information source outside of NXP Semiconductors. In no event shall NXP Semiconductors be liable for any indirect, incidental, punitive, special or consequential damages (including - without limitation - lost profits, lost savings, business interruption, costs related to the removal or replacement of any products or rework charges) whether or not such damages are based on tort (including negligence), warranty, breach of contract or any other legal theory. Notwithstanding any damages that customer might incur for any reason whatsoever, NXP Semiconductors' aggregate and cumulative liability towards customer for the products described herein shall be limited in accordance with the Terms and conditions of commercial sale of NXP Semiconductors.

Right to make changes — NXP Semiconductors reserves the right to make changes to information published in this document, including without limitation specifications and product descriptions, at any time and without notice. This document supersedes and replaces all information supplied prior to the publication hereof.

Suitability for use — NXP Semiconductors products are not designed, authorized or warranted to be suitable for use in life support, life-critical or safety-critical systems or equipment, nor in applications where failure or malfunction of an NXP Semiconductors product can reasonably be expected to result in personal injury, death or severe property or environmental damage. NXP Semiconductors and its suppliers accept no liability for inclusion and/or use of NXP Semiconductors products in such equipment or applications and therefore such inclusion and/or use is at the customer's own risk.

Applications — Applications that are described herein for any of these products are for illustrative purposes only. NXP Semiconductors makes no representation or warranty that such applications will be suitable for the specified use without further testing or modification. Customers are responsible for the design and operation of their applications and products using NXP Semiconductors products, and NXP Semiconductors accepts no liability for any assistance with applications or customer product design. It is customer's sole responsibility to determine whether the NXP Semiconductors product is suitable and fit for the customer's applications and products planned, as well as for the planned application and use of customer's third party customer(s). Customers should provide appropriate design and operating safeguards to minimize the risks associated with their applications and products. NXP Semiconductors does not accept any liability related to any default, damage, costs or problem which is based on any weakness or default in the customer's applications or products, or

the application or use by customer's third party customer(s). Customer is responsible for doing all necessary testing for the customer's applications and products using NXP Semiconductors products in order to avoid a default of the applications and the products or of the application or use by customer's third party customer(s). NXP does not accept any liability in this respect.

Export control — This document as well as the item(s) described herein may be subject to export control regulations. Export might require a prior authorization from competent authorities.

Evaluation products — This product is provided on an "as is" and "with all faults" basis for evaluation purposes only. NXP Semiconductors, its affiliates and their suppliers expressly disclaim all warranties, whether express, implied or statutory, including but not limited to the implied warranties of non-infringement, merchantability and fitness for a particular purpose. The entire risk as to the quality, or arising out of the use or performance, of this product remains with customer. In no event shall NXP Semiconductors, its affiliates or their suppliers be liable to customer for any special, indirect, consequential, punitive or incidental damages (including without limitation damages for loss of business, business interruption, loss of use, loss of data or information, and the like) arising out of the use of or inability to use the product, whether or not based on tort (including negligence), strict liability, breach of contract, breach of warranty or any other theory, even if advised of the possibility of such damages. Notwithstanding any damages that customer might incur for any reason whatsoever (including without limitation, all damages referenced above and all direct or general damages), the entire liability of NXP Semiconductors, its affiliates and their suppliers and customer's exclusive remedy for all of the foregoing shall be limited to actual damages incurred by customer based on reasonable reliance up to the greater of the amount actually paid by customer for the product or five dollars (US\$5.00). The foregoing limitations, exclusions and disclaimers shall apply to the maximum extent permitted by applicable law, even if any remedy fails of its essential purpose.

Translations — A non-English (translated) version of a document is for reference only. The English version shall prevail in case of any discrepancy between the translated and English versions.

Security — Customer understands that all NXP products may be subject to unidentified or documented vulnerabilities. Customer is responsible for the design and operation of its applications and products throughout their lifecycles to reduce the effect of these vulnerabilities on customer's applications and products. Customer's responsibility also extends to other open and/or proprietary technologies supported by NXP products for use in customer's applications. NXP accepts no liability for any vulnerability. Customer should regularly check security updates from NXP and follow up appropriately. Customer shall select products with security features that best meet rules, regulations, and standards of the intended application and make the ultimate design decisions regarding its products and is solely responsible for compliance with all legal, regulatory, and security related requirements concerning its products, regardless of any information or support that may be provided by NXP. NXP has a Product Security Incident Response Team (PSIRT) (reachable at PSIRT@nxp.com) that manages the investigation, reporting, and solution release to security vulnerabilities of NXP products.

11.3 Trademarks

Notice: All referenced brands, product names, service names and trademarks are the property of their respective owners.

NXP — wordmark and logo are trademarks of NXP B.V.

Tables

Tab. 1.	Revision history	2	Tab. 4.	Secondary tabs under Channels	22
Tab. 2.	The pin chart of Arduino connectors and their usage	8	Tab. 5.	Secondary tabs under Groups	27
Tab. 3.	The pin chart of Fuji connectors and their functions	9	Tab. 6.	Abbreviations	36

Figures

Fig. 1.	PCA9957HN-ARD block diagram6	Fig. 13.	Graphical interface – Channels / Gain tab activated 24
Fig. 2.	The PCA9957HN-ARD silkscreen (top view) 10	Fig. 14.	Graphical interface – Channels / Output tab activated 25
Fig. 3.	The PCA9957HN-ARD board picture, top view (up) and bottom view (down) 11	Fig. 15.	Graphical interface – Channels / Gradation tab activated26
Fig. 4.	PCA9957HN-ARD daughter board and IMXRT1050 EVK board, before starting 13	Fig. 16.	Graphical interface – Channels / Errors tab activated 27
Fig. 5.	The assembly PCA9957HN-ARD daughter board / IMXRT1050 EVK board operation 14	Fig. 17.	Graphical interface – Groups / Brightness tab activated28
Fig. 6.	PCA9957HN-ARD daughter board and LPCXpresso55S69 mother board before starting 16	Fig. 18.	Graphical interface – Groups / Blink tab activated 29
Fig. 7.	PCA9957HN-ARD daughter board / LPCXpresso55S69 mother board operation 17	Fig. 19.	Graphical interface – Groups / Gain tab activated 30
Fig. 8.	The assembly PCA9957HN-ARD daughter board, IMX8MMINI-IARD interposer board, and i.MX 8M Mini LPDDR4 EVK before starting 18	Fig. 20.	Graphical interface – Groups / Ramping tab activated 31
Fig. 9.	PCA9957HN-ARD daughter board / i.MX 8M Mini LPDDR4 EVK board operation 19	Fig. 21.	Graphical interface – Groups / Step time tab activated 32
Fig. 10.	Graphical user interface — Settings tab activated 20	Fig. 22.	Graphical interface – Groups / Hold tab activated 33
Fig. 11.	Graphical interface – Global tab activated22	Fig. 23.	Graphical interface – Groups / Gradation tab activated34
Fig. 12.	Graphical interface – Channels / Brightness tab activated23	Fig. 24.	Graphical interface – Groups / Define tab activated 35