

Loop powered sensors

PCC421 series

Table 1: PCC421xx-yy-C model selection guide

| xx (4-20 mA output type) | yy (4-20 mA full scale) | C (output connector) |
|---|---|------------------------|
| AR = acceleration, RMS AP = acceleration, peak | 05 = 5 g (49 m/sec ²) 10 = 10 g (98 m/sec ²) 20 = 20 g (196 m/sec ²) | R6 = 2 pin, MIL-C-5015 |
| VR = velocity, RMS VP = velocity, peak | 05 = 0.5 ips (12.8 mm/sec) 10 = 1.0 ips (25.4 mm/sec) 20 = 2.0 ips (50.8 mm/sec) 50 = 5.0 ips (127 mm/sec) | M12-4 = 4 pin, M12 |



Key features

- Choice of true RMS or calculated peak output (in acceleration or velocity units)
- Connector options: 2 pin MIL-C-5015 or 4 pin M12
- Integral cable option available (PCC423 models)
- Enables continuous trending of machine vibration
- Manufactured in an approved ISO 9001 facility

PCC421xx-yy-C wiring

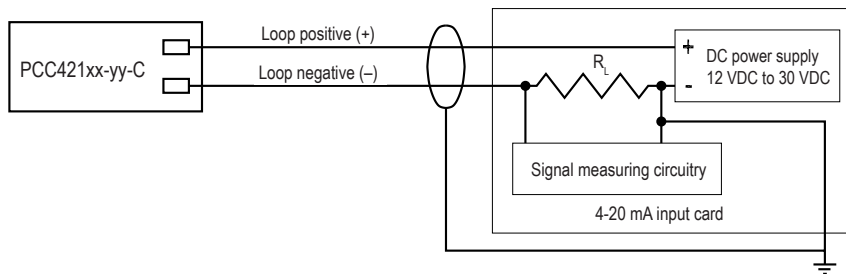

Certifications



Note: Due to continuous process improvement, specifications are subject to change without notice. This document is cleared for public release.

Loop powered sensors

PCC421 series

SPECIFICATIONS

| | |
|---|------------------------------------|
| Output, 4-20 mA | see Table 1 on page 1 |
| Full scale, 4-20 mA, ±5% | selectable (see Table 1) |
| Frequency response, 4-20 mA | see Table 2, below |
| Repeatability | ±2% |
| Transverse sensitivity, max | 5% |
| Power requirements (2-wire loop power): | |
| Voltage at sensor terminals | 12 - 30 VDC |
| Loop resistance¹ at 24 VDC, max | 700 Ω |
| Turn on time, 4-20 mA loop | <30 seconds |
| Grounding | case isolated, internally shielded |
| Temperature range | -40° to +105° C |
| Vibration limit | 250 g peak |
| Shock limit | 2,500 g peak |
| Sealing | hermetic |
| Sensing element design | PZT, shear |
| Weight | 145 grams |
| Case material | stainless steel |
| Mounting | captive screw, 1/4-28 or M6 |
| Output connector | 2 pin MIL-C-5015 or 4 pin M12 |

Accessories supplied: Mounting screw; calibration data (level 2)

Notes: ¹ Maximum loop resistance (R_L) can be calculated by: $R_L = \frac{V_{DC, power} - 10 V}{20 mA}$

| DC supply voltage | R_L (max resistance) ² | R_L (minimum wattage capability) ³ |
|-------------------|-------------------------------------|---|
| 12 VDC | 100 Ω | 1/8 watt |
| 20 VDC | 500 Ω | 1/4 watt |
| 24 VDC | 700 Ω | 1/2 watt |
| 26 VDC | 800 Ω | 1/2 watt |
| 30 VDC | 1,000 Ω | 1/2 watt |

² Lower resistance is allowed, greater than 10 Ω recommended.

³ Minimum R_L wattage determined by: $(0.0004 \times R_L)$.

Table 2: PCC421 frequency response

| Acceleration | ± 10% | 10 Hz - 1 kHz |
|--------------|--------|----------------|
| | ± 3 dB | 1 Hz - 2 kHz |
| Velocity | ± 10% | 10 Hz - 1 kHz |
| | ± 3 dB | 3.5 Hz - 2 kHz |

| MIL-C-5015 pin out (-R6 models) | |
|---------------------------------|---------------|
| Function | Connector pin |
| loop positive (+) | A |
| loop negative (-) | B |
| ground | shell |

| M12 pin out (-M12-4 models) | |
|-----------------------------|---------------|
| Function | Connector pin |
| loop positive (+) | 1 |
| loop negative (-) | 2 |
| N/C | 3 |
| N/C | 4 |
| ground | shell |

Note: Due to continuous process improvement, specifications are subject to change without notice. This document is cleared for public release.

PCC421xx-yy-M12-4

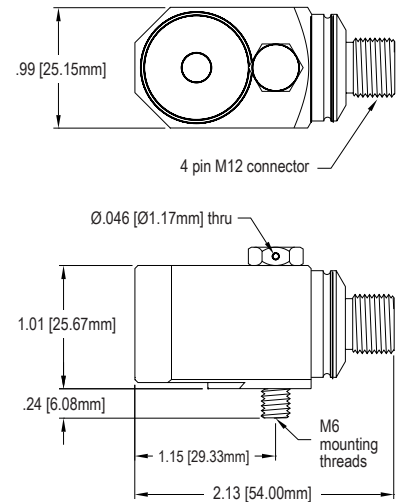

PCC421xx-yy-R6

