

# Loop powered sensors

## PCC421 series

**Table 1: PCC421xx-yy-C model selection guide**

xx (4-20 mA output type)	yy (4-20 mA full scale)	C (output connector)
AR = acceleration, RMS AP = acceleration, peak	05 = 5 g (49 m/sec <sup>2</sup> ) 10 = 10 g (98 m/sec <sup>2</sup> ) 20 = 20 g (196 m/sec <sup>2</sup> )	R6 = 2 pin, MIL-C-5015
VR = velocity, RMS VP = velocity, peak	05 = 0.5 ips (12.8 mm/sec) 10 = 1.0 ips (25.4 mm/sec) 20 = 2.0 ips (50.8 mm/sec) 50 = 5.0 ips (127 mm/sec)	M12-4 = 4 pin, M12



### Key features

- Choice of true RMS or calculated peak output (in acceleration or velocity units)
- Connector options: 2 pin MIL-C-5015 or 4 pin M12
- Integral cable option available (PCC423 models)
- Enables continuous trending of machine vibration
- Manufactured in an approved ISO 9001 facility

### PCC421xx-yy-C wiring

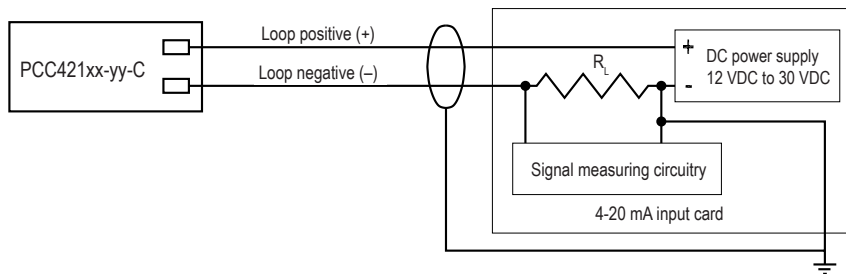

### Certifications



Note: Due to continuous process improvement, specifications are subject to change without notice. This document is cleared for public release.

# Loop powered sensors

## PCC421 series

### SPECIFICATIONS

<b>Output, 4-20 mA</b>	see Table 1 on page 1
<b>Full scale, 4-20 mA, ±5%</b>	selectable (see Table 1)
<b>Frequency response, 4-20 mA</b>	see Table 2, below
<b>Repeatability</b>	±2%
<b>Transverse sensitivity, max</b>	5%
<b>Power requirements (2-wire loop power):</b>	
<b>Voltage at sensor terminals</b>	12 - 30 VDC
<b>Loop resistance<sup>1</sup> at 24 VDC, max</b>	700 Ω
<b>Turn on time, 4-20 mA loop</b>	<30 seconds
<b>Grounding</b>	case isolated, internally shielded
<b>Temperature range</b>	-40° to +105° C
<b>Vibration limit</b>	250 g peak
<b>Shock limit</b>	2,500 g peak
<b>Sealing</b>	hermetic
<b>Sensing element design</b>	PZT, shear
<b>Weight</b>	145 grams
<b>Case material</b>	stainless steel
<b>Mounting</b>	captive screw, 1/4-28 or M6
<b>Output connector</b>	2 pin MIL-C-5015 or 4 pin M12

**Accessories supplied:** Mounting screw; calibration data (level 2)

**Notes:** <sup>1</sup> Maximum loop resistance ( $R_L$ ) can be calculated by:  $R_L = \frac{V_{DC, power} - 10 V}{20 mA}$

DC supply voltage	$R_L$ (max resistance) <sup>2</sup>	$R_L$ (minimum wattage capability) <sup>3</sup>
12 VDC	100 Ω	1/8 watt
20 VDC	500 Ω	1/4 watt
24 VDC	700 Ω	1/2 watt
26 VDC	800 Ω	1/2 watt
30 VDC	1,000 Ω	1/2 watt

<sup>2</sup> Lower resistance is allowed, greater than 10 Ω recommended.

<sup>3</sup> Minimum  $R_L$  wattage determined by:  $(0.0004 \times R_L)$ .

**Table 2: PCC421 frequency response**

Acceleration	± 10%	10 Hz - 1 kHz
	± 3 dB	1 Hz - 2 kHz
Velocity	± 10%	10 Hz - 1 kHz
	± 3 dB	3.5 Hz - 2 kHz

MIL-C-5015 pin out (-R6 models)	
Function	Connector pin
loop positive (+)	A
loop negative (-)	B
ground	shell

M12 pin out (-M12-4 models)	
Function	Connector pin
loop positive (+)	1
loop negative (-)	2
N/C	3
N/C	4
ground	shell

Note: Due to continuous process improvement, specifications are subject to change without notice. This document is cleared for public release.

### PCC421xx-yy-M12-4

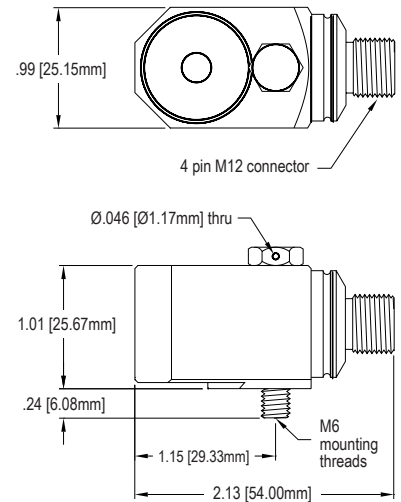

### PCC421xx-yy-R6

