

# PCF85053A

Bootable CPU RTC with two I<sup>2</sup>C buses, 128 byte SRAM and alarm function

Rev. 1.0 — 31 January 2023

Product data sheet

## 1 General description

---

The PCF85053A is a CMOS Real-Time Clock (RTC) and calendar optimized for low power consumption and automatic switching to battery on primary power loss. Featuring clock output, ALRT (interrupt) output and 128 bytes of battery backup SRAM. The PCF85053A includes two I<sup>2</sup>C buses. The primary I<sup>2</sup>C bus has the read/write capability on RTC and SRAM registers. The second I<sup>2</sup>C bus also can read/write most registers with the control bits set by primary I<sup>2</sup>C controller. The PCF85053A offers clock output calibration-related registers such as crystal CL(capacitive load) configuration and offset register setting.

## 2 Features and benefits

---

- Supply voltage: 1.7 V to 3.6 V
- Battery supply voltage: 1.55 V to 3.6 V
- Provides year, month, day, weekday, hours, minutes and seconds based on a 32.768 kHz quartz crystal
- Device addresses
  - RTC: 1101 111
  - SRAM: 1010 111
- Two independent I<sup>2</sup>C with speed 400 kHz Max.
  - I<sup>2</sup>C clock Timeout 35 ms max
  - Primary I<sup>2</sup>C bus
    - Read/write capability on RTC and SRAM registers
    - Active low  $\overline{\text{ALRT}}$  (interrupt) output
  - Second I<sup>2</sup>C bus
    - Read/write capability on RTC and SRAM registers enabled by primary I<sup>2</sup>C
- I<sup>2</sup>C bus not active during battery switchover
- Real-time clock and calendar
- Align to MC146818B Register Definition for Offset 0 to 09h
- Support both Binary Mode and BCD Mode.
- Support 24-hour and 12-hour Mode.
- Support Daylight Saving Mode.
- Interrupt Flag Support
- RTC\_CLR Flag
- Alarm Flag
- RTC Fail Flag
- Oscillator Fail Flag
- Battery-backed 128 byte SRAM
- SRAM Clear to '0' by RTC\_CLR Pin
- Frequency adjustment via programmable offset register
- Configurable oscillator circuit for a wide variety of quartzes: CL = 6 pF, CL = 7 pF, and CL = 12.5 pF
- Operating temperature range T<sub>amb</sub>: -40 °C to 85 °C



### 3 Applications

- Server and computer precision timekeeping
- Network-powered and industrial electronics
- Products with long automated unattended operation time
- White goods

### 4 Ordering information

Table 1. Ordering information

Type number	Topside mark	Package		
		Name	Description	Version
PCF85053ATK	85053	HVSON12	plastic thermal enhanced very thin small outline package; 12 terminals; 0.5 mm pitch; 3 mm x 3 mm x 0.85 mm body	SOT2143-1

#### 4.1 Ordering options

Table 2. Ordering options

Type number	Orderable part number	Package	Packing method	Minimum order quantity	Temperature
PCF85053ATK	PCF85053ATKJ	HVSON12	REEL 13" Q1/ T1 *STANDARD MARK SMD	6000	T <sub>amb</sub> = -40 °C to +85 °C

### 5 Block diagram

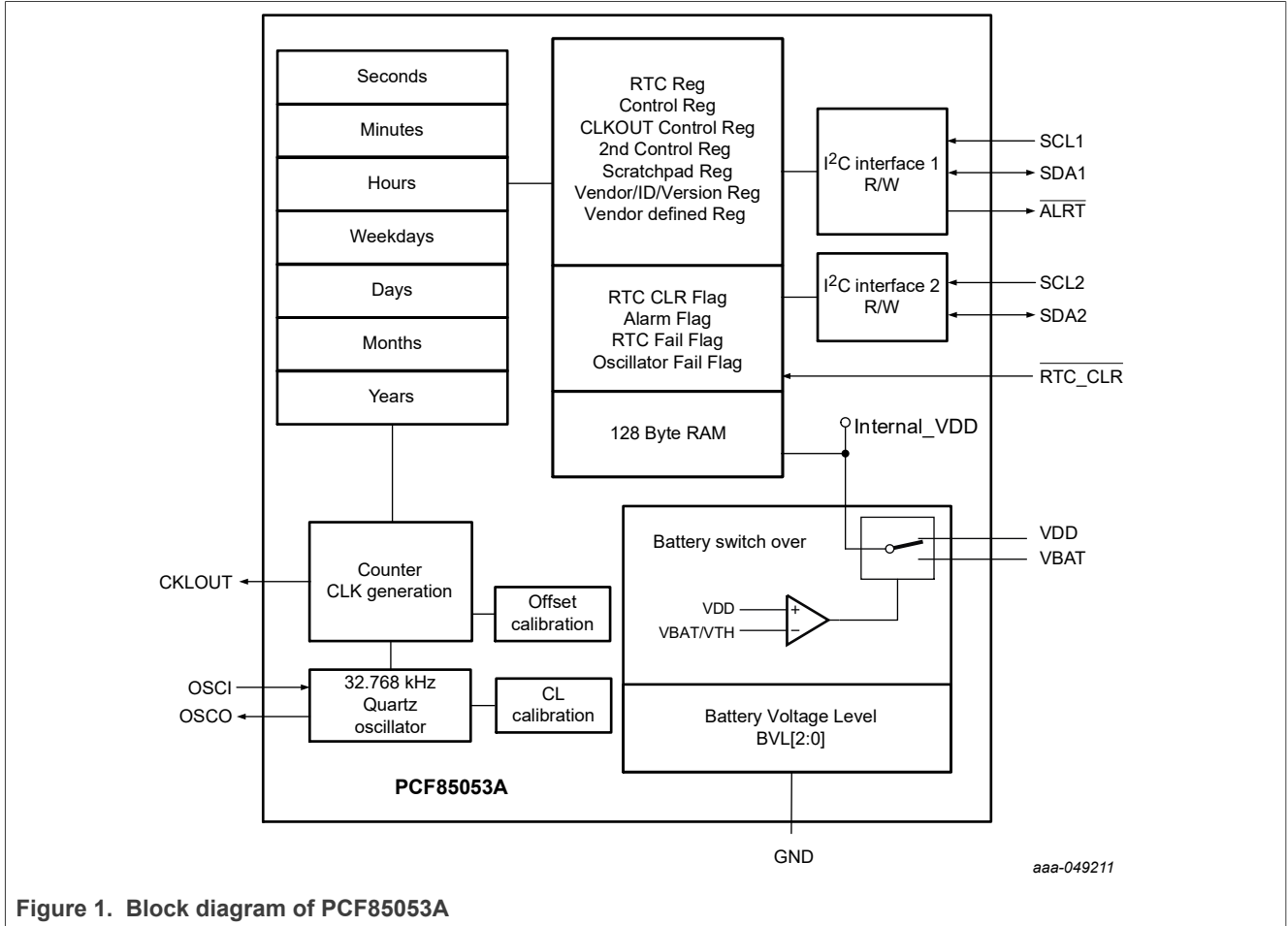

Figure 1. Block diagram of PCF85053A

## 6 Pinning information

### 6.1 Pinning

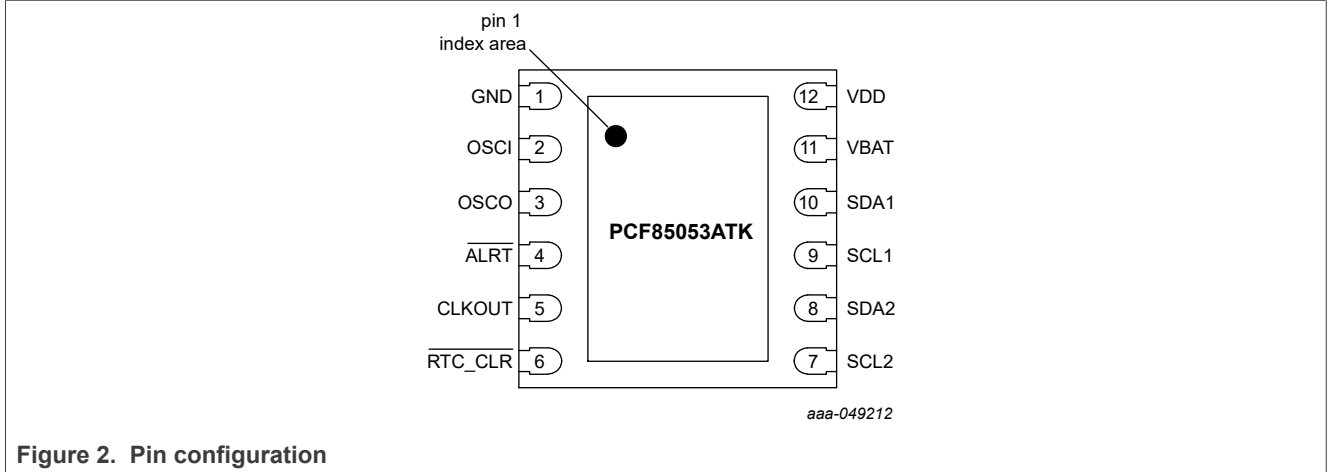

Figure 2. Pin configuration

### 6.2 Pin description

Table 3. Pin description of PCF85053A

Symbol	Pin	Type	Description
GND <sup>[1]</sup>	1	supply	ground supply voltage
OSCI	2	I	oscillator input
OSCO	3	O	oscillator output
ALRT	4	O	interrupt output, open-drain and active-low
CLKOUT	5	O	clock output
RTC_CLR	6	I	active low to clear battery-backed SRAM
SCL2	7	I	2 <sup>nd</sup> I <sup>2</sup> C bus serial clock
SDA2	8	I/O	2 <sup>nd</sup> I <sup>2</sup> C bus serial data
SCL1	9	I	primary I <sup>2</sup> C bus serial clock
SDA1	10	I/O	primary I <sup>2</sup> C bus serial data
V <sub>BAT</sub>	11	supply	battery backup supply voltage
V <sub>DD</sub>	12	supply	supply voltage

[1] The exposed pad should be connected to GND.

## 7 Functional description

The PCF85053A contains 8-bit registers for time information and 128 byte SRAM-related system configuration. Included is an auto-incrementing register address, an on-chip 32.768 kHz oscillator with integrated capacitors, a frequency divider which provides the source clock for the real-time Clock (RTC) and calendar, and two I<sup>2</sup>C-bus interfaces with a maximum frequency 400 kHz.

The first I<sup>2</sup>C bus can read all RTC and SRAM registers including read and write most of registers except the read-only registers.

The second I<sup>2</sup>C bus can read all RTC and SRAM registers, while write capability for some registers is blocked, or gated by the primary I<sup>2</sup>C bus. (See [Table 6](#).)

The built-in address register will increment automatically after each read or write of a data byte. After register FFh, the auto-incrementing will wrap around to address 00h. When the SRAM is accessed, the wrap-around will happen after address 7Fh (see [Figure 3](#)).

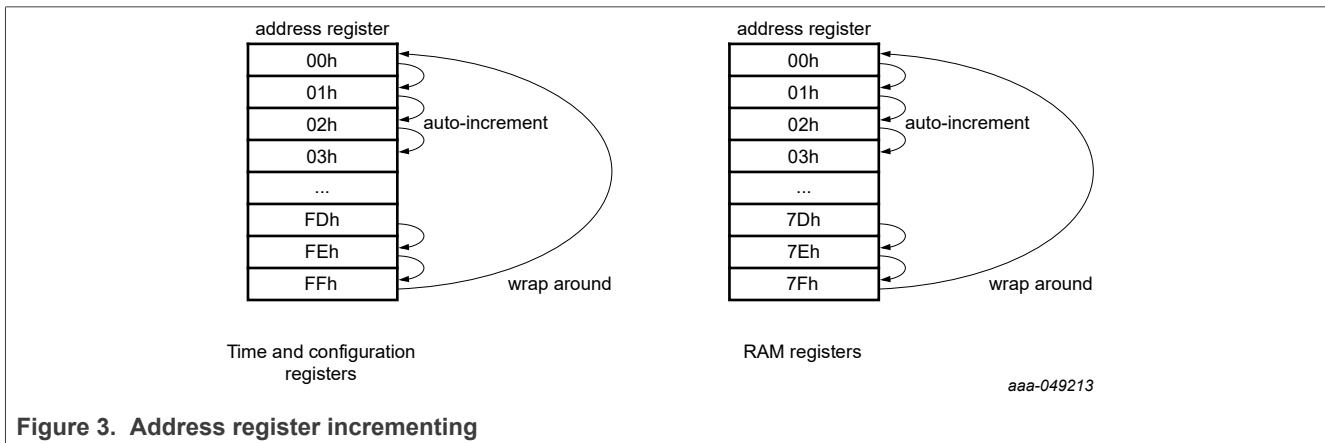

Figure 3. Address register incrementing

All registers are designed as addressable 8-bit parallel registers although not all bits are implemented.

The seconds, minutes, hours, days, months, and years as well as the corresponding alarm registers are all coded in Binary Coded Decimal (BCD) format or binary format.

When reading the RTC time registers, the contents of all time registers are frozen. Therefore, faulty reading of the clock and calendar during a carry condition is prevented. The internal counters are running at background to maintain the time accuracy.

### 7.1 RTC and SRAM registers overview

The I<sup>2</sup>C device addresses of RTC and SRAM are shown in [Table 4](#).

Table 4. Device addresses of RTC and SRAM

Device	Device address
RTC	1101 111
SRAM	1010 111

The time registers are aligned to MC146818B Register Definition for Offset 0 to 09h. They can be coded in the BCD format or binary format.

The other registers (0Ah to 11h) are the control register, status register, CLKOUT control register, version register,...etc.

See [Table 5](#) for register map, [Table 6](#) and [Table 7](#) for the two I<sup>2</sup>C buses read/write capability.

The 128 byte SRAM data address range is from 00h to 7Fh. See [Table 8](#) and [Table 9](#) for SRAM register map and read/write capability by the two I<sup>2</sup>C buses.

## 7.1.1 RTC register map

Table 5. RTC register map

Address	Register	BCD Data Mode									Binary Mode	Default <sup>[1]</sup>	
		D7	D6	D5	D4	D3	D2	D1	D0	Range			Range
00h	Seconds	0	x10 Seconds			x1 Seconds				00-59	00-3B	00h	
01h	Seconds Alarm	0	x10 Seconds			x1 Seconds				00-59	00-3B	00h	
02h	Minutes	0	x10 mins			x1 Minutes				00-59	00-3B	00h	
03h	Minutes Alarm	0	x10 mins			x1 Minutes				00-59	00-3B	00h	
04h	Hours (12 Hour Mode)	0:AM 1:PM	0	x10 Hours			x1 Hours				1-12	01-0C (AM) 81-8C (PM)	12h
	Hours (24 Hour Mode)	0	0	x10 Hours			x1 Hours				00-23	00-17	12h
05h	Hours Alarm (12 Hour Mode)	0:AM 1:PM	0	x10 Hours			x1 Hours				1-12	01-0C (AM) 81-8C (PM)	12h
	Hours Alarm (24 Hour Mode)	0	0	x10 Hours			x1 Hours				00-23	00-17	12h
06h	Day of the Week (Sunday =1)	Day of Week								1-7	01-07	07h	
07h	Day of the Month <sup>[2]</sup>	Day of Month								1-31	01-1F	01h	
08h	Month	Month								1-12	01-0C	01h	
09h	Year	Year								0-99	00-63	00h	
0Ah	Control Register	ST	DM	HF	DSM	AIE	OFIE	CIE	TWO	-	-	00h	
0Bh	Status Register	AF	OF	RTCF	CIF	-	BVL2	BVL1	BVL0	-	-	-	
0Ch	CLKOUT Control	CKE	-	-	-	-	-	CKD[1:0]		-	-	00h	
0Dh	2 <sup>nd</sup> Control Register	-	-	-	-	-	-	-	MWO			00h	
0Eh	Scratchpad	Scratchpad register										00h	
0Fh	Version Register	Major Version				Minor Version				-	-	10h	
10h	Vendor ID Register	Vendor Code										4Eh	
11h	Model Register	Model Code										52h	
12h	Offset	OFFSET[7:0]									-	-	00h
13h	Oscillator	CLKIV	OFFM	-	LOWJ	OSCD[1:0]		CL[1:0]				02h	
14h	Access config	XCLK	-	-	-	-	-	-	-	-	-	00h	
15h	Sec_timestp	0	x10 Seconds			x1 Seconds				00-59	00-3B	00h	
16h	Min_timestp	0	x10 mins			x1 Minutes				00-59	00-3B	00h	

Table 5. RTC register map...continued

Address	Register	BCD Data Mode					Binary Mode	Default <sup>[1]</sup>
17h	Hour_timestp (12 Hour Mode)	0:AM 1:PM	0	x10 Hours	x1 Hours	1-12	01-0C (AM) 81-8C (PM)	12h
	Hour_timestp (24 Hour Mode)	0	0	x10 Hours	x1 Hours	00-23	00-17	12h
18h	DayWk_timestp (Sunday =1)	Day of Week				1-7	01-07	07h
19h	DayMon_timestp	Day of Month				1-31	01-1F	01h
1Ah	Mon_timestp	Month				1-12	01-0C	01h
1Bh	Year_timestp	Year				0-99	00-63	00h
1Ch	R_code1	R code 1				-	-	00h
1Dh	R_code2	R code 2				-	-	00h
1Eh to FFh	reserved	reserved				-	-	00h

[1] After power up, all registers are set to the associated default value.

[2] If the year counter contains a value, which is exactly divisible by 4, the PCF85053A compensates for leap years by adding a 29th day to February

### 7.1.2 RTC register read/write capability by the two I<sup>2</sup>C buses

Table 6. RTC Register read/write capability by the two I<sup>2</sup>C buses

Address	Register	Primary I <sup>2</sup> C		2nd I <sup>2</sup> C		Note
		TWO=1	TWO=0 (default)	TWO=1	TWO=0 (default)	
<b>control bit TWO</b> (see <a href="#">Section 7.4.1 Table 16</a> )						<b>Only primary I<sup>2</sup>C controller can write "TWO" bit</b>
00h	Seconds	Read/Write	Read only	Read only	Read/Write	
01h	Seconds Alarm	Read/Write		Read only		
02h	Minutes	Read/Write	Read only	Read only	Read/Write	
03h	Minutes Alarm	Read/Write		Read only		
04h	Hours (12 Hour Mode)	Read/Write	Read only	Read only	Read/Write	
	Hours (24 Hour Mode)	Read/Write	Read only	Read only	Read/Write	
05h	Hours Alarm (12 Hour Mode)	Read/Write		Read only		
	Hours Alarm (24 Hour Mode)	Read/Write		Read only		
06h	Day of the Week (Sunday =1)	Read/Write	Read only	Read only	Read/Write	

Table 6. RTC Register read/write capability by the two I<sup>2</sup>C buses...continued

Address	Register	Primary I <sup>2</sup> C		2nd I <sup>2</sup> C		Note
07h	Day of the Month	Read/Write	Read only	Read only	Read/Write	
08h	Month	Read/Write	Read only	Read only	Read/Write	
09h	Year	Read/Write	Read only	Read only	Read/Write	
0Ah	Control Register	Read/Write	Read/Write	Read only	Read only	
0Bh	Status Register	Read/Write	Read/Write	Read only	Read only	
<b>control bit XCLK</b> (see <a href="#">Section 7.9 Table 35</a> )		<b>XCLK=1</b>	<b>XCLK=0</b> (default)	<b>XCLK=1</b>	<b>XCLK=0</b> (default)	<b>Only primary I<sup>2</sup>C controller can write "XCLK" bit</b>
0Ch	CLKOUT Control	Read/Write	Read only	Read only	Read/Write	For clock calibration The primary I <sup>2</sup> C can change the access capability see <a href="#">Section 7.9</a>
12h	Offset Register	Read/Write	Read only	Read only	Read/Write	For clock calibration The primary I <sup>2</sup> C can change the access capability see section <a href="#">Section 7.9</a>
13h	Oscillator Register	Read/Write	Read only	Read only	Read/Write	For clock calibration The primary I <sup>2</sup> C can change the access capability see section <a href="#">Section 7.9</a>
<b>Access config</b>		<b>Primary I<sup>2</sup>C</b>		<b>2nd I<sup>2</sup>C</b>		
0Dh	2 <sup>nd</sup> Control Register	Read/Write		Read only		
0Eh	Scratchpad	Read/Write		Read only		
14h	Access config	Read/Write		Read only		

Table 7. RTC Read only registers

Address	Register	Primary I <sup>2</sup> C	2nd I <sup>2</sup> C
0Fh to 11h	Version Model related registers	Read only	Read only
15h to 1Dh	Timestamp and R_code registers	Read only	Read only
1Eh to FFh	reserved	Read only	Read only

### 7.1.3 SRAM register map

Table 8. SRAM register map

Address	Register name	Reset By	Default	Note
00h-7Fh	SRAM Byte	RTC_CLR	00h	128 bytes of battery backup SRAM



Table 9. SRAM registers read/write capability by the two I<sup>2</sup>C buses

Address	Register	Primary I <sup>2</sup> C		2nd I <sup>2</sup> C		Note
		MWO=1	MWO=0 (default)	MWO=1	MWO=0 (default)	
control bit MWO (see section 7.4.4 and Table 23)						Only primary I <sup>2</sup> C controller can write "MWO" bit. This bit is in RTC 2 <sup>nd</sup> control register.
00h-7Fh	SRAM Byte	Read/Write	Read only	Read only	Read/Write	

## 7.2 Time, calendar and alarm registers (00h to 09h)

The processor program can access time and calendar information by reading the appropriate locations. The contents of the time, calendar and alarm registers (00h to 09h) may be either binary or binary-code decimal(BCD). These registers are updated once per second.

See Table 10 for time register format and Table 11 for read/write capability configuration.

The read/write capability configuration is set by the TWO (Time Register Write Ownership) bit. See section Section 7.4.1 Table 15.

Table 10. Time register map

Address	Register	BCD Data Mode								Binary Mode	Default
		D7	D6	D5	D4	D3	D2	D1	D0		
00h	Seconds	0	x10 Seconds			x1 Seconds			00-59	00-3B	00h
01h	Seconds Alarm	0	x10 Seconds			x1 Seconds			00-59	00-3B	00h
02h	Minutes	0	x10 mins			x1 Minutes			00-59	00-3B	00h
03h	Minutes Alarm	0	x10 mins			x1 Minutes			00-59	00-3B	00h
04h	Hours (12 Hour Mode)	0:AM 1:PM	0	x10 Hours		x1 Hours			1-12	01-0C (AM) 81-8C (PM)	12h
	Hours (24 Hour Mode)	0	0	x10 Hours		x1 Hours			00-23	00-17	12h
05h	Hours Alarm (12 Hour Mode)	0:AM 1:PM	0	x10 Hours		x1 Hours			1-12	01-0C (AM) 81-8C (PM)	12h
	Hours Alarm (24 Hour Mode)	0	0	x10 Hours		x1 Hours			00-23	00-17	12h
06h	Day of the Week (Sunday =1)	Day of Week							1-7	01-07	01h
07h	Day of the Month	Day of Month							1-31	01-1F	01h
08h	Month	Month							1-12	01-0C	01h
09h	Year	Year							0-99	00-63	00h

Table 11. Time registers read/write capability configuration

Address	Register	Primary I <sup>2</sup> C		2nd I <sup>2</sup> C		Note
		TWO=1	TWO=0 (default)	TWO=1	TWO=0 (default)	
control bit TWO (see section 7.4.1 Table 15)						Only primary I <sup>2</sup> C controller can write "TWO" bit
00h	Seconds	Read/Write	Read only	Read only	Read/Write	

Table 11. Time registers read/write capability configuration...continued

Address	Register	Primary I <sup>2</sup> C		2nd I <sup>2</sup> C		Note
01h	Seconds Alarm	Read/Write	Read only	Read only		
02h	Minutes	Read/Write	Read only	Read only	Read/Write	
03h	Minutes Alarm	Read/Write	Read only	Read only		
04h	Hours (12 Hour Mode)	Read/Write	Read only	Read only	Read/Write	
	Hours (24 Hour Mode)	Read/Write	Read only	Read only	Read/Write	
05h	Hours Alarm (12 Hour Mode)	Read/Write	Read only	Read only		
	Hours Alarm (24 Hour Mode)	Read/Write	Read only	Read only		
06h	Day of the Week (Sunday =1)	Read/Write	Read only	Read only	Read/Write	
07h	Day of the Month	Read/Write	Read only	Read only	Read/Write	
08h	Month	Read/Write	Read only	Read only	Read/Write	
09h	Year	Read/Write	Read only	Read only	Read/Write	
0Ah	Control Register	Read/Write	Read/Write	Read only	Read only	
0Bh	Status Register	Read/Write	Read/Write	Read only	Read only	

### 7.2.1 BCD time format

The Binary-Coded Decimal (BCD) encodes numbers where each digit is represented by a separate bit field. Each bit field may only contain the values 0 to 9. In this way, decimal numbers and counting is implemented.

Example: 59 encoded as an entire number is represented by 3Bh or 111011. In BCD the 5 is represented as 5h or 0101 and the 9 as 9h or 1001 which combines to 59h (see [Table 12](#)).

Table 12. BCD format

Value in decimal	Upper-digit (ten's place)				Digit (unit place)			
	D7	D6	D5	D4	D3	D2	D1	D0
00	0	0	0	0	0	0	0	0
01	0	0	0	0	0	0	0	1
02	0	0	0	0	0	0	1	0
...	...	...	...	...	...	...	...	...
58	0	1	0	1	1	0	0	0
59	0	1	0	1	1	0	0	1
..	...	...	...	...	...	...	...	...
98	1	0	0	1	1	0	0	0
99	1	0	0	1	1	0	0	1

### 7.2.2 Setting and reading the time registers

The data flow and data dependencies starting from the 1 Hz clock tick (see [Figure 4](#)).

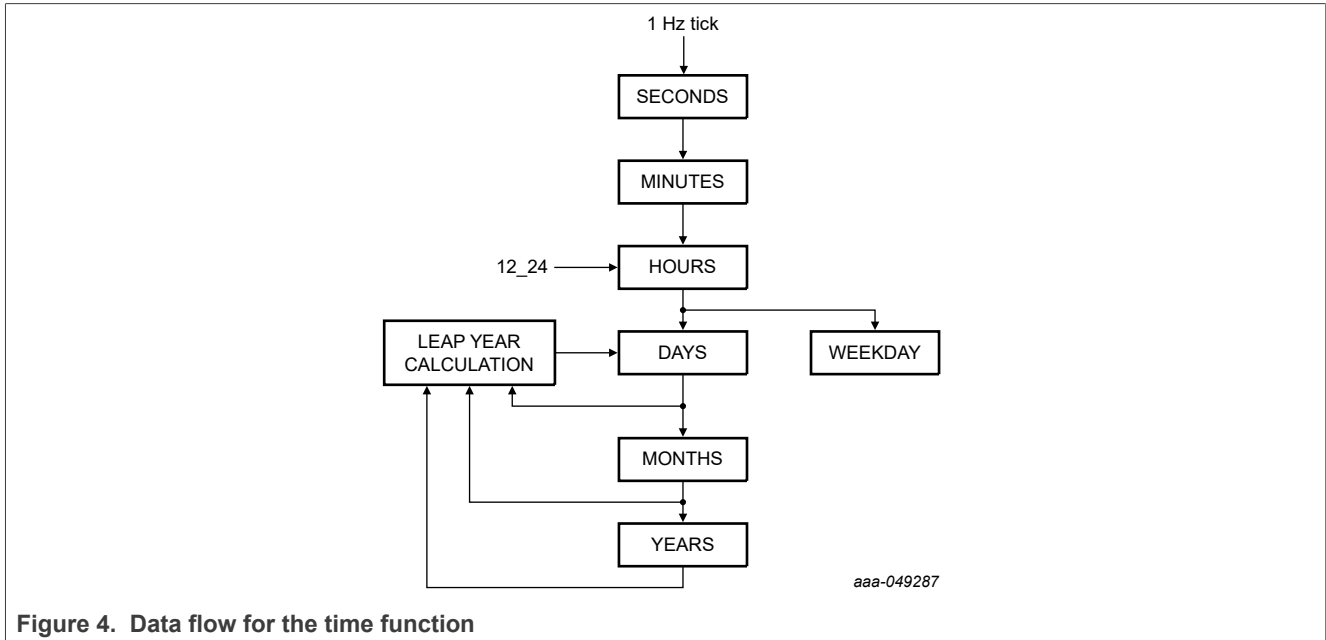

Figure 4. Data flow for the time function

During read operations, the time registers are copied into an output register. The RTC continues counting in the background. When reading or writing the time it is very important to make a read or write access in one go, that is, setting or reading seconds through to years should be made in one single access. Failing to comply with this method could result in the time becoming corrupted.

### 7.3 Alarm registers (01h, 03h and 05h)

The alarm registers are located at 01h for seconds alarm, 03h for minutes alarm, 05h for hours alarm.

The three alarm bytes may be used in two ways. First, when the program inserts an alarm time in the appropriate hours, minutes, and seconds alarm locations, the alarm interrupt is initiated at the specified time each day if the AIE alarm interrupt enable bit is high. The second usage is to insert a "don't care" state in one or more of three alarm bytes.

**The "don't care" code is any hexadecimal byte from C0 to FF.** That is, the two most-significant bits of each byte, when set to "1", create a "don't care" situation.

- An alarm interrupt **each hour** is created with a "don't care" code in the hours alarm byte.
- An alarm interrupt **each minute** is created with "don't care" codes in the hours and minutes alarm bytes.
- An alarm interrupt **each second** is created with a "don't care" code in the hours, minutes and seconds alarm bytes.

See [Table 13](#) for Alarm register details.

Table 13. Alarm registers

Address	Register	BCD Range	Binary Range	Default	Primary I <sup>2</sup> C	2nd I <sup>2</sup> C
01h	Seconds Alarm	00-59	00-3B	00h	Read/Write	Read only
03h	Minutes Alarm	00-59	00-3B	00h	Read/Write	Read only

Table 13. Alarm registers...continued

Address	Register	BCD Range	Binary Range	Default	Primary I <sup>2</sup> C	2nd I <sup>2</sup> C
05h	Hours Alarm (12 Hour Mode)	1-12	01-0C (AM) 81-8C (PM)	12h	Read/Write	Read only
	Hours Alarm (24 Hour Mode)	00-23	00-17	12h	Read/Write	Read only

## 7.4 Control, status, CLKOUT, and 2nd control register (0Ah to 0Dh)

The control register is to control related RTC function.

The status register is to show the status of alarm setting, oscillator status and battery voltage range.

The CLKOUT register is to for clock output configuration.

The second control register is the additional control register.

See [Table 14](#) for read/write capability setting.

Table 14. Control, status, CLKOUT, and 2nd control registers read/write capability configuration

Address	Register	Primary I <sup>2</sup> C	2nd I <sup>2</sup> C	Note
0Ah	Control Register	Read/write	Read only	
0Bh	Status Register	Read/write	Read only	
0Dh	2 <sup>nd</sup> Control Register	Read/write	Read only	
0Ch	CLKOUT Control	Read/write (XCLK=1)	Read/write (XCLK=0)	See <a href="#">Section 7.9 Table 37</a>

### 7.4.1 Control register (0Ah)

Table 15. Control register byte

Address	Register	D7	D6	D5	D4	D3	D2	D1	D0
0Ah	Control Register	ST	DM	HF	DSM	AIE	OFIE	CIE	TWO

Table 16. Control register bit detail

Bit	Symbol	Reset by	Value	Description
D7	ST (Stop)	N/A	0	Normal Mode
			1	Stop the RTC
D6	DM (Data Mode)	N/A	0	BCD Mode
			1	Binary Mode
D5	HF (Hour Format)	N/A	0	12 Hour Mode
			1	24 Hour Mode
D4	DSM (Daylight Saving Mode)	N/A	0	Disable Daylight Saving Mode
			1	Enable Daylight saving Mode
D3	AIE (Alarm Interrupt Enable)	RTC_CLR	0	Disable Alarm Interrupt
			1	Enable Alarm Interrupt. Allows an interrupt to occur when the AF is set from an alarm match from the update cycle.

Table 16. Control register bit detail...continued

Bit	Symbol	Reset by	Value	Description
				An alarm can occur once a second, one an hour, once a day
D2	OFIE (Oscillator Fail Interrupt Enable)	RTC_CLR	0	Disable the Oscillator Fail Interrupt
			1	Enable the Oscillator Fail Interrupt
D1	CIE (RTC Clear Interrupt Enable)	N/A	0	Disable interrupt ( $\overline{\text{ALRT}}$ Assertion) when the $\overline{\text{RTC\_CLR}}$ assertion is detected
			1	Enable interrupt ( $\overline{\text{ALRT}}$ Assertion) when the $\overline{\text{RTC\_CLR}}$ assertion is detected
D0	TWO (Time Reg Write Ownership)	N/A	0	2nd I <sup>2</sup> C bus has the write access to the Time registers
			1	Primary I <sup>2</sup> C bus has the write access to the Time registers.

7.4.1.1 ST bit function

The function of the ST (stop) bit is to allow for accurate starting of the time circuits. The ST bit function will cause the upper part of the prescaler (F2 to F14) to be held in reset and thus no 1 Hz ticks will be generated (see Figure 5). The time circuits can then be set and will not increment until the ST bit is released (see Figure 6 and Table 17).

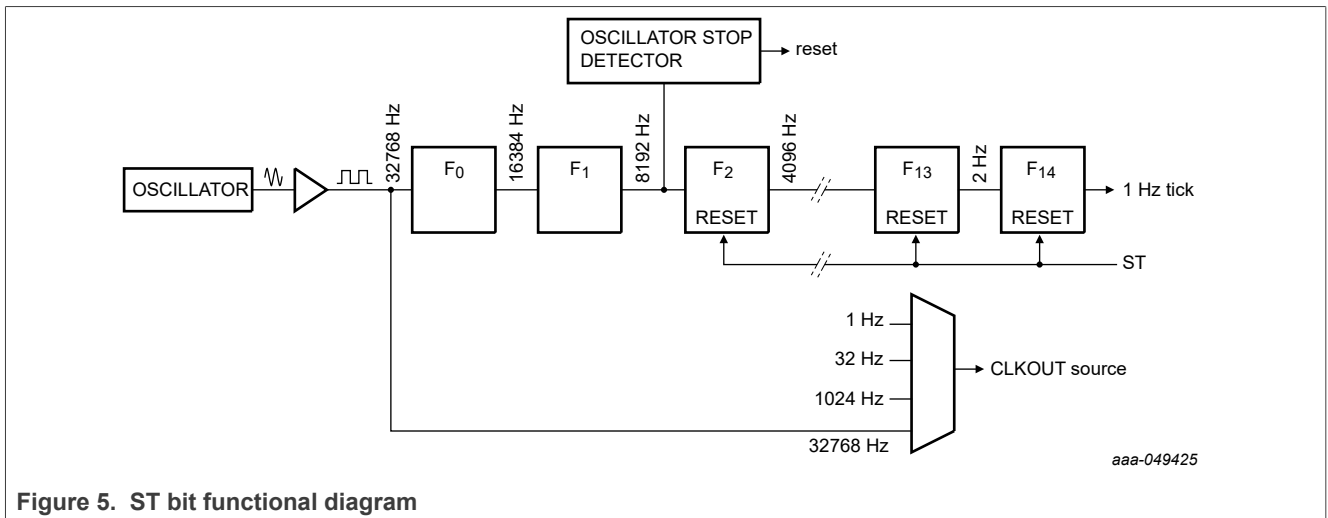

The ST bit function will not affect the output of 32.768 kHz on CLKOUT, but will stop the generation of 1.024 kHz, 32 Hz, and 1 Hz.

The lower two stages of the prescaler (F0 and F1) are not reset; and because the I<sup>2</sup>C-bus is asynchronous to the crystal oscillator, the accuracy of re-starting the time circuits will be between zero and one 8.192 kHz cycle (see Figure 6).

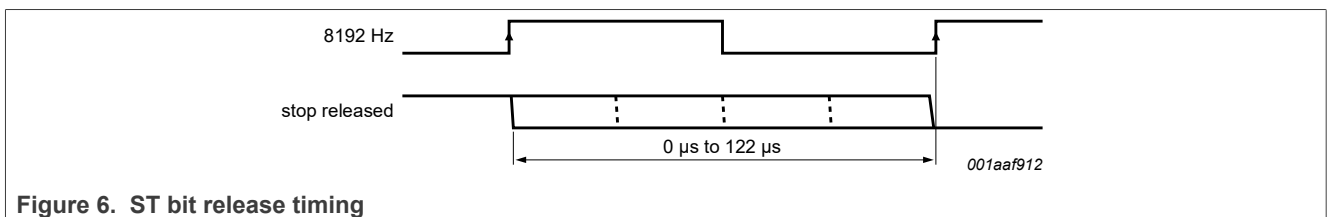

Table 17. First increment of time circuits after ST bit release

Bit	Prescaler bits	[1]	1 Hz tick	Time	Comment
ST	F <sub>0</sub> F <sub>1</sub> -F <sub>2</sub> to F <sub>14</sub>			hh:mm:ss	
<b>Clock is running normally</b>					
0	01-0 0001 1101 0100			12:45:12	prescaler counting normally
<b>ST bit is activated by user. F<sub>0</sub>F<sub>1</sub> are not reset and values cannot be predicted externally</b>					
1	XX-0 0000 0000 0000			12:45:12	prescaler is reset; time circuits are frozen
<b>New time is set by user</b>					
1	XX-0 0000 0000 0000			08:00:00	prescaler is reset; time circuits are frozen
<b>ST bit is released by user</b>					
0	XX-0 0000 0000 0000			08:00:00	prescaler is now running
	XX-1 0000 0000 0000			08:00:00	-
	XX-0 1000 0000 0000			08:00:00	-
	XX-1 1000 0000 0000			08:00:00	-
	:			:	:
	11-1 1111 1111 1110			08:00:00	-
	00-0 0000 0000 0001			08:00:01	0 to 1 transition of F <sub>14</sub> increments the time circuits
	10-0 0000 0000 0001			08:00:01	-
	:			:	:
	11-1 1111 1111 1111			08:00:01	-
	00-0 0000 0000 0000			08:00:01	-
	10-0 0000 0000 0000			08:00:01	-
	:			:	-
	11-1 1111 1111 1110			08:00:01	-
	00-0 0000 0000 0001			08:00:02	0 to 1 transition of F <sub>14</sub> increments the time circuits

[1] F<sub>0</sub> is clocked at 32.768 kHz.

The first increment of the time circuits is between 0.507813 s and 0.507935 s after ST bit is released. The uncertainty is caused by the prescaler bits F<sub>0</sub> and F<sub>1</sub> not being reset (see Table 17) and the unknown state of the 32 kHz clock.

7.4.1.2 DSM bit function

The daylight saving mode is enabled by DSM (Daylight Saving Mode) =1. The spec is shown below:

- The first Sunday in April, where time increments from 1:59:59 AM to 3:00:00 AM.
- The last Sunday in October when the time first reaches 1:59:59 AM, it is changed to 1:00:00 AM

7.4.2 Status register (0Bh)

Status register (0Bh) describes the statuses of Alarm flag, oscillator fail bit, RTC fail bit and RTC clear flag (see [Table 18](#) and [Table 19](#)).

The BVL[2:0] bits are measured and updated once per second.

Table 18. Status register byte

Address	Register	D7	D6	D5	D4	D3	D2-D0
0Bh	Status Register	AF	OF	RTCF	CIF	Rsvd	BVL[2:0] <sup>[1]</sup>

[1] BVL[2:0] are read only.

Table 19. Status register bit detail

Bit	Symbol	Reset by	Value	Description
D7	AF (Alarm Flag)	RTC_CLR	1	after all Alarm values Match the current time.
			0	Write '0' to clear it.
D6	OF (Oscillator Fail Bit/Flag)	N/A	1	Set when oscillator failed/stopped. Set in following Conditions: 1. First Time power is applied. 2. Oscillator has failed ( freq is either zero or very far away from the desired 32.768KHz) 3. The ST Bit is Set to '1'
			0	Write '0' to clear it.
D5	RTCF (RTC Fail Bit)	N/A	1	Set when device powers up after lost all power (V <sub>DD</sub> and V <sub>BAT</sub> ).
			0	Write '0' to Clear it.
D4	CIF (RTC Clear Flag)	N/A	1	Set when the RTC_CLR Pin assertion is detected.
			0	Write '0' to clear it.
D3	Rsvd	N/A	-	Reserved
D2 – D0	BVL[2:0]	N/A	000	Battery Voltage Level ≤1.7 V
			001	Battery Voltage Level (1.7 V, 1.9V]
			010	Battery Voltage Level (1.9V, 2.1V]
			011	Battery Voltage Level (2.1V, 2.3V]
			100	Battery Voltage Level (2.3V, 2.5V]
			101	Battery Voltage Level (2.5V, 2.7 V]
			110	Battery Voltage Level (2.7 V, 3.0V]
			111	Battery Voltage Level > 3.0V

7.4.2.1 OF (Oscillator Fail Flag)

The OF flag is set whenever the oscillator is “first time power is applied”, “Oscillator has failed” (see [Section 7.4.2.1](#)) or “the ST Bit is Set to ‘1’”. The flag remains set until cleared by using the I<sup>2</sup>C interface. When the oscillator is not running, then the OF flag cannot be cleared. This method can be used to monitor the oscillator.

The oscillator may be stopped, for example, by grounding one of the oscillator pins, OSCI or OSCO. The oscillator is also considered to be stopped during the time between power-on and stable crystal resonance. This time may be in a range of 200 ms to 2 s, depending on crystal type, temperature, and supply voltage.

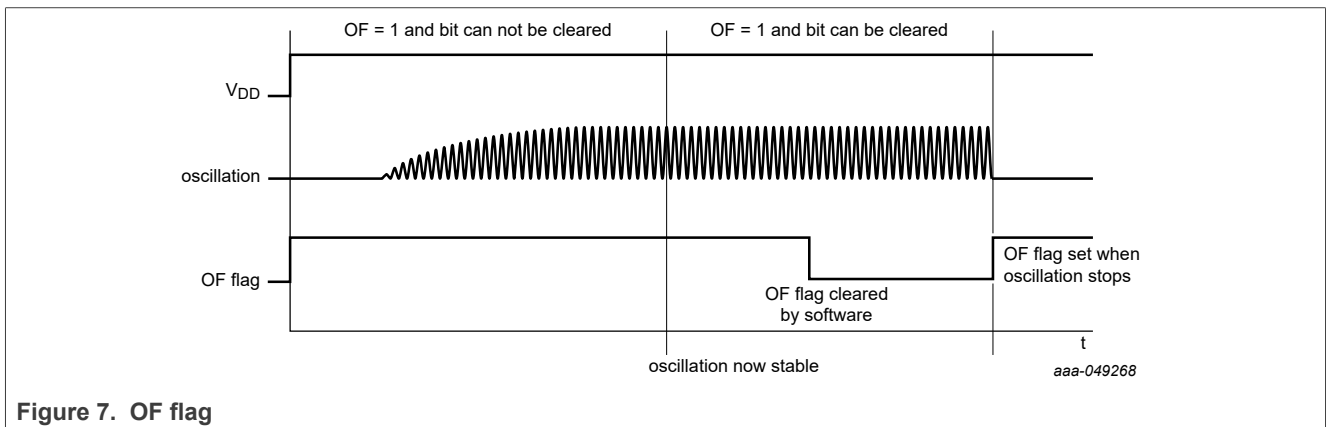

7.4.3 CLKOUT Control register (0Ch)

Table 20. CLKOUT Control register byte

Address	Register	D7	D6	D5	D4	D3	D2	D1	D0
0Ch	CLKOUT Control	CKE	Rsvd	Rsvd	Rsvd	Rsvd	Rsvd	CKD1	CKD0

Table 21. Status register bit detail

Bit	Symbol	Value	Description
D7	CKE (Clock Output Enable)	1	The Clock Output is activated. Note: Clock Output is always disabled when only powered by V <sub>BAT</sub> . (V <sub>DD</sub> is not valid)
		0	CLKOUT output is inhibited and pin is set to high-impedance
D6-D2	Rsvd	-	Reserved
D1-D0	CKD[1:0]	00	32.768 kHz
		01	1.024 kHz
		10	32 Hz
		11	1 Hz

7.4.4 2nd Control Register (0Dh)

Table 22. 2<sup>nd</sup> Control register byte

Address	Register	D7	D6	D5	D4	D3	D2	D1	D0
0Dh	2 <sup>nd</sup> control register	Rsvd	Rsvd	Rsvd	Rsvd	Rsvd	Rsvd	Rsvd	MWO



Table 23. 2<sup>nd</sup> control register bit detail

Bit	Symbol	Reset by	Value	Description
D7-D1	Rsvd	N/A	-	Reserved
D0	MWO	RTC_CLR	0	2 <sup>nd</sup> I <sup>2</sup> C bus has the write access to the SRAM registers
			1	Primary I <sup>2</sup> C bus has the write access to the SRAM registers.

If an I<sup>2</sup>C write transaction is performed on the secondary I<sup>2</sup>C bus while the primary I<sup>2</sup>C bus writes to the 2nd Control register, the synchronization of the internal MWO state may be delayed.

While writing to this 2nd Control register, ensure there is no ongoing write on the secondary I<sup>2</sup>C bus. If not, perform an I<sup>2</sup>C read or write transaction of any register on the primary I<sup>2</sup>C bus to have a correct MWO state.

### 7.5 Scratchpad register (0Eh)

Table 24. Scratchpad register byte

Address	Register	D7-D0	default	Primary I <sup>2</sup> C	2nd I <sup>2</sup> C
0Eh	Scratchpad	Scratchpad register	00h	Read/Write	Read only

### 7.6 Version related register (0Fh, 10h and 11h)

Table 25. Version, Vendor and Part number register byte

Address	Register	D7	D6	D5	D4	D3	D2	D1	D0
0Fh	Version	0	0	0	1	0	0	0	0
10h	Vendor	0	1	0	0	1	1	1	0
11h	Model	0	1	0	1	0	0	1	0

### 7.7 Offset register (12h)

The PCF85053A incorporates an offset register (address 12h) which can be used to implement several functions, such as:

- Accuracy tuning
- Aging adjustment
- Temperature compensation

See [Table 26](#) for register description and [Table 27](#) for read/write capability configuration.

Table 26. Offset - offset register byte (default value : 00h)

Address	Register	D7 – D0	Description
12h	Offset	OFFSET[7:0] see <a href="#">Table 29</a>	Offset value

Table 27. Offset registers read/write capability by the two I<sup>2</sup>C buses

Address	Register	Primary I <sup>2</sup> C		2nd I <sup>2</sup> C		Note
	<b>control bit XCLK</b>	<b>XCLK=1</b>	<b>XCLK=0 (default)</b>	<b>XCLK=1</b>	<b>XCLK=0 (default)</b>	<b>Only primary I<sup>2</sup>C controller can write “XLK” bit</b>
12h	Offset Register	Read/Write	Read only	Read only	Read/Write	For clock calibration

Bootable CPU RTC with two I<sup>2</sup>C buses, 128 byte SRAM and alarm function

Table 27. Offset registers read/write capability by the two I<sup>2</sup>C buses...continued

Address	Register	Primary I <sup>2</sup> C		2nd I <sup>2</sup> C		Note
						The primary I <sup>2</sup> C can change the access capability (see <a href="#">Section 7.9</a> )

There are two modes which define the correction period, normal mode and fast mode.

The normal mode is suitable for offset trimming. The fast mode is suitable for dynamic offset correction e.g. implementing a temperature correction. The fast mode consumes more current. Offset mode is defined by bit OFFM in the Oscillator register.

To program a new OFFSET[7:0] or OFFM value, it requires to wait 135 ms min after an OFFSET[7:0] or OFFM write-event respectively.

Table 28. OFFM bit - oscillator control register (address 13h)

See [Section 7.8.2](#)

Bit	Symbol	Value	Description
6	OFFM		offset mode bit
		0 (default)	normal mode: correction is made every 4 hours; 2.170 ppm/step
		1	fast mode: correction is made once every 8 minutes; 2.0345 ppm/step

For OFFM = 0, each LSB introduces an offset of 2.170 ppm. For OFFM = 1, each LSB introduces an offset of 2.0345 ppm. The offset value is coded in two's complement giving a range of +127 LSB to -128 LSB, (see [Table 29](#)).

Table 29. Offset values

OFFSET[7:0]	Offset value in decimal	Offset value in ppm	
		Normal mode OFFM = 0	Fast mode OFFM = 1
01111111	+127	+275.590	+258.3815
01111110	+126	+273.420	+256.3470
:			:
00000010	+2	+4.340	+4.0690
00000001	+1	+2.170	+2.0345
00000000IU	0	0 (default)	0
11111111	-1	-2.170	-2.0345
11111110	-2	-4.340	-4.0690
:			:
10000001	-127	-275.590	-258.3815
10000000	-128	-277.760	-260.416

The correction is made by adding or subtracting clock correction pulses, thereby changing the period of a single second but not by changing the oscillator frequency.

It is possible to monitor when correction pulses are applied.

**7.7.1 Correction when OFFM = 0**

The correction is triggered once every four hours and then correction pulses are applied once per minute until the programmed correction values have been implemented.

**Table 30. Correction pulses for OFFM = 0**

Correction value	Every n <sup>th</sup> hour	Actual minute
+1 or -1	4	00
+2 or -2	4	00 and 01
+3 or -3	4	00, 01, and 02
:	:	:
+59 or -59	4	00 to 58
+60 or -60	4	00 to 59
+61 or -61	4	00 to 59
	4 + 1	00
+62 or -62	4	00 to 59
	4 + 1	00 and 01
:	:	:
+123 or -123	4	00 to 59
	4 + 1	00 to 59
	4+2	00, 01, and 02
-128	4	00 to 59
	4 + 1	00 to 59
	4+2	00 to 07

**7.7.2 Correction when OFFM = 1**

The correction is triggered once every eight minutes and then correction pulses are applied once per second until the programmed correction values have been implemented.

Clock correction is made more frequently in OFFM = 1; however, this can result in higher power consumption.

**Table 31. Correction pulses for OFFM = 1**

Correction value	Every n <sup>th</sup> minute	Actual second
+1 or -1	8	00
+2 or -2	8	00 and 01
+3 or -3	8	00, 01, and 02
:	:	:
+59 or -59	8	00 to 58
+60 or -60	8	00 to 59
+61 or -61	8	00 to 59
	8 + 1	00
+62 or -62	8	00 to 59

Table 31. Correction pulses for OFFM = 1...continued

Correction value	Every n <sup>th</sup> minute	Actual second
	8 + 1	00 and 01
:	:	:
+123 or -123	8	00 to 59
	8 + 1	00 to 59
	8 + 2	00, 01, and 02
-128	8	00 to 59
	8 + 1	00 to 59
	8 + 2	00 to 07

7.7.3 Offset calibration workflow

The calibration offset has to be calculated based on the time. Figure 8 shows the workflow how the offset register values can be calculated. Figure 9 shows the result of offset calibration.

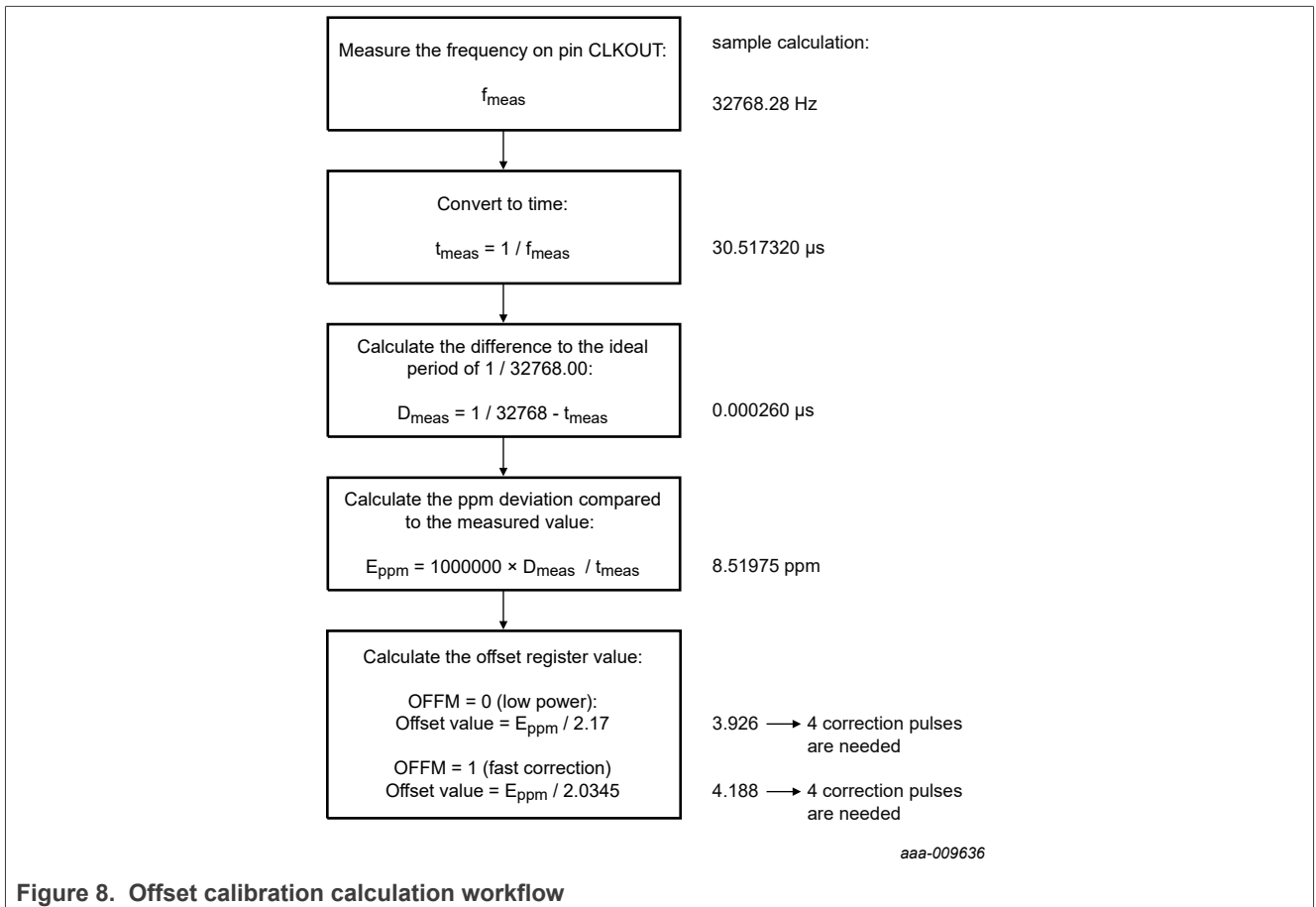
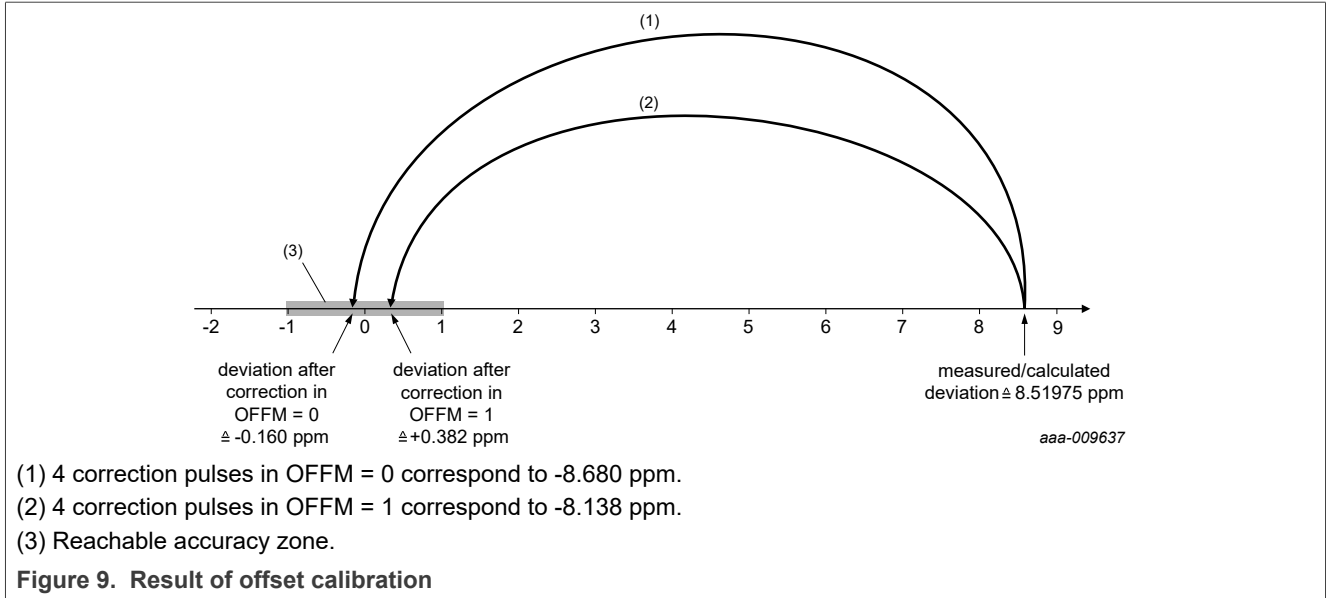

Figure 8. Offset calibration calculation workflow



### 7.8 Oscillator register (13h)

Table 32. Oscillator register byte

Address	Register	D7	D6	D5	D4	D3	D2	D1	D0
13h	Oscillator	CLKIV	OFFM	-	LOWJ	OSCD[1:0]		CL[1:0]	

Table 33. Oscillator register read/write capability configuration

Address	Register	Primary I <sup>2</sup> C		2nd I <sup>2</sup> C		Note
		XCLK=1	XCLK=0 (default)	XCLK=1	XCLK=0 (default)	
13h	Oscillator Register	Read/Write	Read only	Read only	Read/Write	Only primary I <sup>2</sup> C controller can write "XCLK" bit  For clock calibration The primary I <sup>2</sup> C can change the access capability (see section <a href="#">Section 7.9</a> )

Table 34. Oscillator register bit detail (default value: 00h)

Bit	Symbol	Value	Description
D7	CLKIV	0 (default)	non-inverting; LOWJ mode will affect rising edge
		1	inverted; LOWJ mode will affect falling edge
D6	OFFM	0 (default)	normal mode: correction is made every 4 hours
		1	fast mode: correction is made once every 8 minutes
D5	Rsvd	-	reserved
D4	LOWJ	0 (default)	normal mode
		1	reduced CLK output jitter; increase I <sub>DD</sub>
D3-D2	OSCD[1:0]	00 (default)	normal drive; Rs(max)- 100 kΩ

Table 34. Oscillator register bit detail (default value: 00h)...continued

Bit	Symbol	Value	Description
		01	low drive; Rs(max)- 60 kΩ; reduced I <sub>DD</sub>
		10, 11	high drive; Rs(max): 500 kΩ; increased I <sub>DD</sub>
D1-D0	CL[1:0]	00	7.0 pF
		01	6.0 pF
		10(default) 11	12.5 pF

### 7.8.1 CLKIV: invert the clock output (bit 7)

The clock selected with the CKD[1:0] bits (register CLKOUT Control, address 0Ch) can be inverted. This is intended for use in conjunction with the low jitter mode, LOWJ. The low jitter mode reduces the jitter for the rising edge of the output clock. If the reduced jitter needs to be on the falling edge, for example when using an open-drain clock output, then the CLKIV bit can be used to implement this.

### 7.8.2 OFFM: offset calibration mode (bit 6)

The OFFM is for offset normal mode and fast mode selection, see [Section 7.7](#) for a full description of offset calibration.

### 7.8.3 LOWJ: low jitter mode (bit 4)

Oscillator circuits suffer from jitter. In particular, ultra low-power oscillators like the one used in the PCF85053A are optimized for power and not jitter. By setting the LOWJ bit, the jitter performance can be improved at the cost of power consumption.

### 7.8.4 OSCD[1:0]: quartz oscillator drive control (bit 3, bit 2)

The oscillator is designed to be used with quartz with a series resistance up to 100 kΩ. This covers the typical range of 32.768 kHz quartz crystals. Series resistance is also referred to as: ESR, motional resistance, or RS.

A low drive mode is available for low series resistance quartz. This reduces the current consumption.

For very high series resistance quartz, there is a high drive mode. Current consumption increases substantially in this mode.

### 7.8.5 CL[1:0]: quartz oscillator load capacitance (bit 1, bit 0)

CL refers to the load capacitance of the oscillator circuit and allows for a certain amount of package and PCB parasitic capacitance. When the oscillator circuit matches the CL parameter of the quartz, then the frequency offset is zero.

The PCF85053A is designed to operate with quartz with CL values of 6.0 pF, 7.0 pF, and 12.5 pF.

12.5 pF are generally the cheapest and most widely available, but also require the most power to drive. The circuit also operates with 9.0 pF quartz, however the offset calibration would be needed to compensate. If a 9.0 pF quartz is used, then it is recommended to set CL to 7.0 pF.

## 7.9 Access register (14h)

Only primary I<sup>2</sup>C controller can write this Access register.

XCLK is the control bit to determine CLKOUT control (0Ch), Offset (12h) and oscillator (13h) registers read/write capability by the two I<sup>2</sup>C buses. See [Table 35](#) and [Table 37](#).

Table 35. Access – access control register byte

Address	Register	D7	D6-D0
14h	Access	XCLK	reserved

Table 36. Access registers read/write capability configuration

Address	Register	Primary I <sup>2</sup> C	2nd I <sup>2</sup> C
14h	Access	Read/Write	Read only

Table 37. Access register bit detail (default value: 00h)

Bit	Symbol	Value	Description
D7	XCLK	0 (default)	The second I <sup>2</sup> C interface control the clock out calibration capability. Register 0Ch, 12h and 13h.
		1	The primary I <sup>2</sup> C interface control the clock out calibration capability. Register 0Ch, 12h and 13h.
D6-D0	rsvd	-	reserved

Table 38. XCLK bit detail (default value: 0)

XCLK	Register	Primary I <sup>2</sup> C	Secondary I <sup>2</sup> C	description
0 (default)	CLKOUT Control (0Ch) Offset (12h) Oscillator(13h)	Read only	Read/write	The second I <sup>2</sup> C controls the clock calibration.
1	CLKOUT Control (0Ch) Offset (12h) Oscillator(13h)	Read/write	Read only	The primary I <sup>2</sup> C controls the clock calibration.

### 7.10 Timestamp registers (15h to 1Bh)

The timestamp is to record the time for the RTC time register write-event for advanced time accuracy offset register setting. The timestamp registers are from 15h to 1Bh (see [Table 39](#)).

The timestamp will not record the time for Alarm registers (01h, 03h and 05h) write-event.

Table 39. Timestamp registers

Address	Register	BCD Data Mode								Binary Mode	Default	
		D7	D6	D5	D4	D3	D2	D1	D0			Range
15h	Sec_timestp	0	x10 Seconds			x1 Seconds			00-59	00-3B	00h	
16h	Min_timestp	0	x10 mins			x1 Minutes			00-59	00-3B	00h	
17h	Hour_timestp (12 Hour Mode)	PM/ AM	0	x10 Hours			x1 Hours			1-12	01-0C (AM) 81-8C (PM)	12h

Table 39. Timestamp registers...continued

Address	Register	BCD Data Mode					Binary Mode	Default
		0	0	x10 Hours	x1 Hours	00-23		
	Hour_timestp (24 Hour Mode)	0	0	x10 Hours	x1 Hours	00-23	00-17	12h
18h	DayWk_timestp (Sunday =1)	Day of Week				1-7	01-07	07h
19h	DayMon_timestp	Day of Month				1-31	01-1F	01h
1Ah	Mon_timestp	Month				1-12	01-0C	01h
1Bh	Year_timestp	Year				0-99	00-63	00h

### 7.11 R code registers (1Ch to 1Dh)

The R code registers are two-byte random numbers and read only for security application. It takes 200 μs max to generate the R code after a timestamp event.

### 7.12 Battery switch-over function

PCF85053A has the feature of battery switch-over. The internal power input will switch to battery operation when V<sub>DD</sub> is less than 1.5 V typ.

When switched to battery, the V<sub>DD</sub> power domain is disabled. This means that I<sup>2</sup>C pins are ignored, CLK output is disabled and Hi-Z.

### 7.13 128 byte SRAM (device address 1010 111)

There is a 128 byte SRAM available from address 00h to 7Fh. The SRAM can be written and read when powered from V<sub>DD</sub>. The SRAM content is backed-up when the device is powered from V<sub>BAT</sub>, but cannot be accessed as the interface is disabled.

The address pointer is set during interface initiation and will auto increment after each byte access. The pointer will wrap around from address 7Fh to 00h after the last byte is accessed (see [Figure 10](#)).

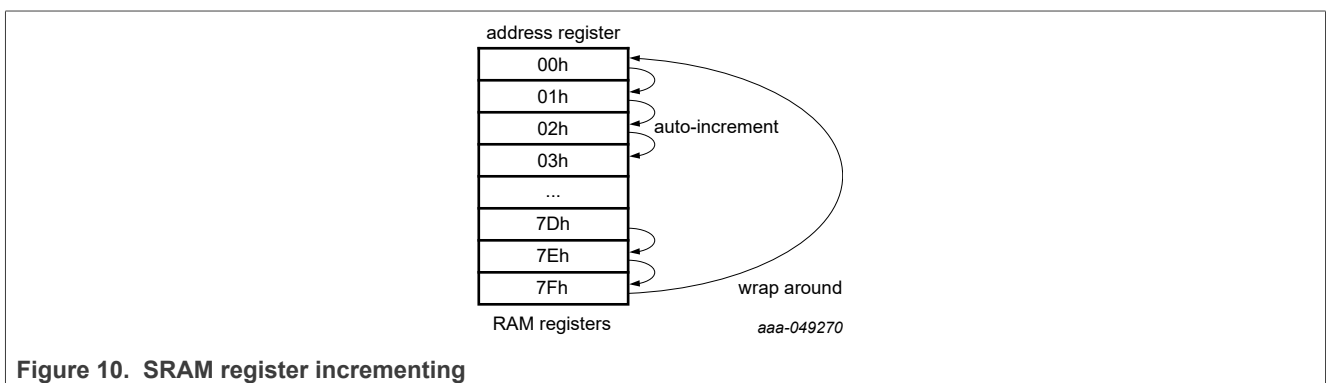

Figure 10. SRAM register incrementing

The SRAM read/write capability is determined by the MWO bit and can be reset by RTC\_CLR (see [Table 40](#) and [Table 41](#)).

Table 40. SRAM register map

Address	Register name	Reset By	Default	Note
00h-7Fh	SRAM Byte	RTC_CLR	00h	128 bytes of battery backup SRAM



Table 41. SRAM registers read/write capability by the two I<sup>2</sup>C buses

Address	Register	Primary I <sup>2</sup> C		2nd I <sup>2</sup> C		Note
		MWO=1	MWO=0 (default)	MWO=1	MWO=0 (default)	
control bit MWO (see section <a href="#">Section 7.4.4</a> and <a href="#">Table 23</a> )						Only primary I <sup>2</sup> C controller can write "MWO" bit. This bit is in RTC 2 <sup>nd</sup> control register.
00h-7Fh	SRAM Byte	Read/Write	Read only	Read only	Read/Write	

### 7.14 I<sup>2</sup>C-bus interface

The I<sup>2</sup>C-bus is for bidirectional, two-line communication between different ICs or modules. The two lines are a Serial DATA line (SDA) and a Serial CLOCK line (SCL). Both lines must be connected to a positive supply via a pull-up resistor. Data transfer may be initiated only when the bus is not busy.

#### 7.14.1 Bit transfer

One data bit is transferred during each clock pulse. The data on the SDA line must remain stable during the HIGH period of the clock pulse, as changes in the data line at this time are interpreted as a control signal (see [Figure 11](#)).

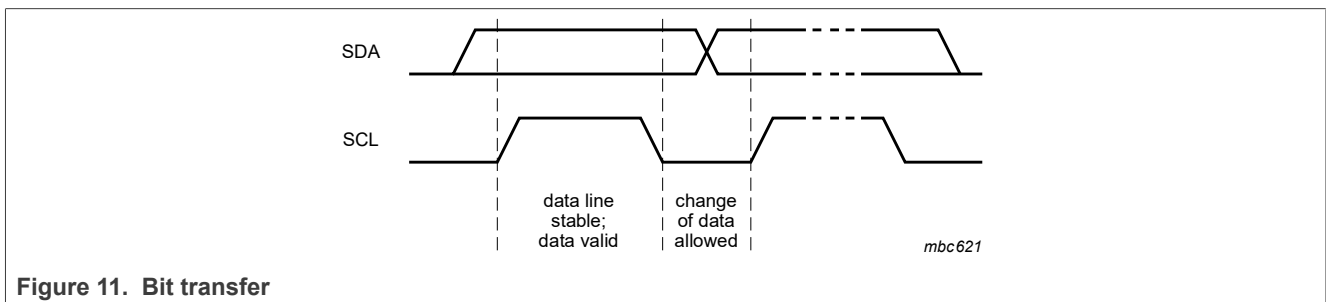

Figure 11. Bit transfer

#### 7.14.2 START and STOP conditions

Both data and clock lines remain HIGH when the bus is not busy.

A HIGH-to-LOW transition of the data line while the clock is HIGH is defined as the START condition - S.

A LOW-to-HIGH transition of the data line while the clock is HIGH is defined as the STOP condition - P (see [Figure 12](#)).

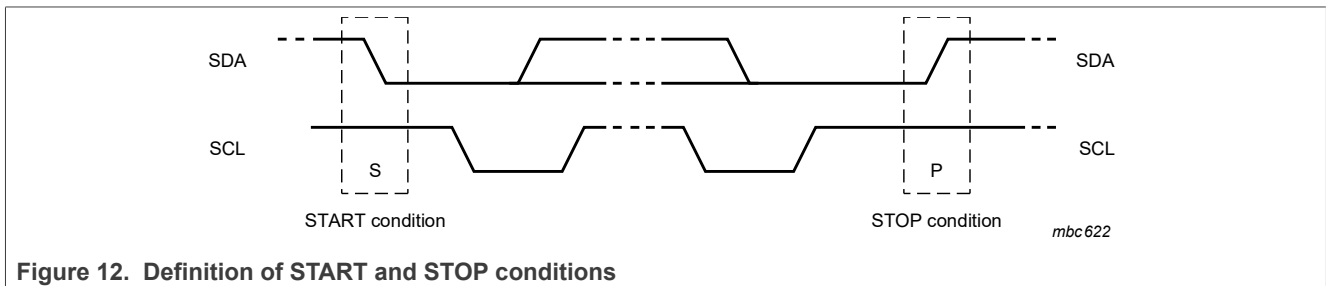

Figure 12. Definition of START and STOP conditions

#### 7.14.3 System configuration

A device generating a message is a transmitter; a device receiving a message is a receiver. The device that controls the message is the controller; and the devices which are controlled by the controller are the targets (see [Figure 13](#)).

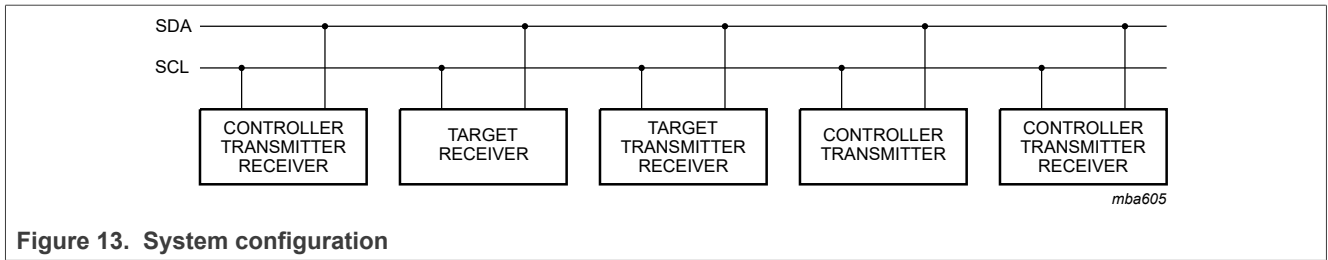

Figure 13. System configuration

7.14.4 Acknowledge

The number of data bytes transferred between the START and STOP conditions from transmitter to receiver is unlimited. Each byte of 8 bits is followed by an acknowledge cycle.

- A target receiver, which is addressed, must generate an acknowledge after the reception of each byte
- Also a controller receiver must generate an acknowledge after the reception of each byte that has been clocked out of the target transmitter
- The device that acknowledges must pull-down the SDA line during the acknowledge clock pulse, so that the SDA line is stable LOW during the HIGH period of the acknowledge related clock pulse (set-up and hold times must be considered)
- A controller receiver must signal an end of data to the transmitter by not generating an acknowledge on the last byte that has been clocked out of the target. In this event, the transmitter must leave the data line HIGH to enable the controller to generate a STOP condition

Acknowledgement on the I<sup>2</sup>C-bus is shown in Figure 14.

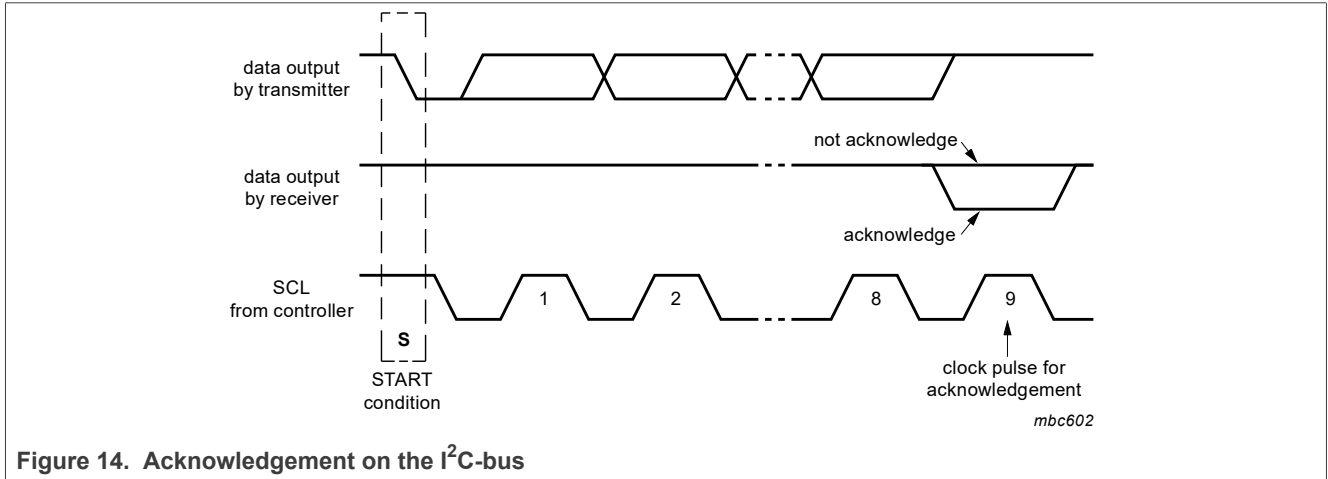

Figure 14. Acknowledgement on the I<sup>2</sup>C-bus

7.14.5 I<sup>2</sup>C-bus protocol

After a start condition, a valid hardware address has to be sent to a I<sup>2</sup>C device. The appropriate I<sup>2</sup>C-bus target addresses for RTC and SRAM shown in Table 42.

Table 42. I<sup>2</sup>C target address byte

Register	D7	D6	D5	D4	D3	D2	D1	D0(R/W)	HEX
RTC	1	1	0	1	1	1	1	0:Write 1:Read	DEh :Write DFh: Read
SRAM	1	0	1	0	1	1	1	0:Write 1:Read	A Eh :Write AFh: Read

The  $\overline{RW}$  bit defines the direction of the following single or multiple byte data transfer (read is logic 1, write is logic 0).

#### 7.14.5.1 Write protocol

After the I<sup>2</sup>C target address is transmitted, the PCF85053A requires that the register address pointer is defined. It can take the value 00h to FFh for RTC and 00h to 7Fh for SRAM. Values outside of that range will result in the transfer being ignored, however the target will still respond with acknowledge pulses.

After the register address is transmitted, write data is transmitted. The minimum number of data write bytes is 0 and the maximum number is unlimited. After each write, the address pointer increments by one. After address FFh for RTC or 7Fh for SRAM, the address pointer will roll over to 00h.

- I<sup>2</sup>C START condition
- I<sup>2</sup>C target address + write
- register address
- write data
- write data
- :
- write data
- I<sup>2</sup>C STOP condition; an I<sup>2</sup>C RE-START condition is also possible.

#### 7.14.5.2 Read protocol

When reading the PCF85053A, reading starts at the current position of the address pointer. The address pointer for read data should first be defined by a write sequence.

- I<sup>2</sup>C START condition
- I<sup>2</sup>C target address + write
- register address
- I<sup>2</sup>C STOP condition; an I<sup>2</sup>C RE-START condition is also possible.

After setting the address pointer, a read can be executed. After the I<sup>2</sup>C target address is transmitted, the PCF85053A will immediately output read data. After each read, the address pointer increments by one. After address FFh for RTC or 7Fh for SRAM, the address pointer will roll over to 00h.

- I<sup>2</sup>C START condition
- I<sup>2</sup>C target address + read
- read data (controller sends acknowledge bit)
- read data (controller sends acknowledge bit)
- :
- read data (controller sends not-acknowledge bit)
- I<sup>2</sup>C STOP condition. An I<sup>2</sup>C RE-START condition is also possible.

The controller must indicate that the last byte has been read by generating a not-acknowledge after the last read byte.

For the detail format and the timing of the START condition (S), the STOP condition (P), and the acknowledge (A) refer to the I<sup>2</sup>C-bus specification UM10204 and the characteristics table ([Table 44](#)).

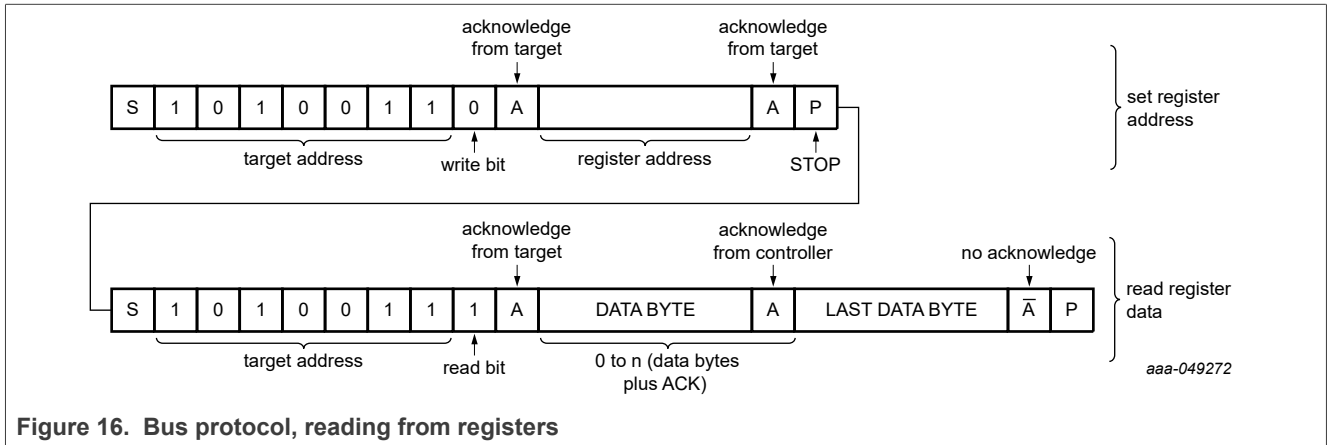
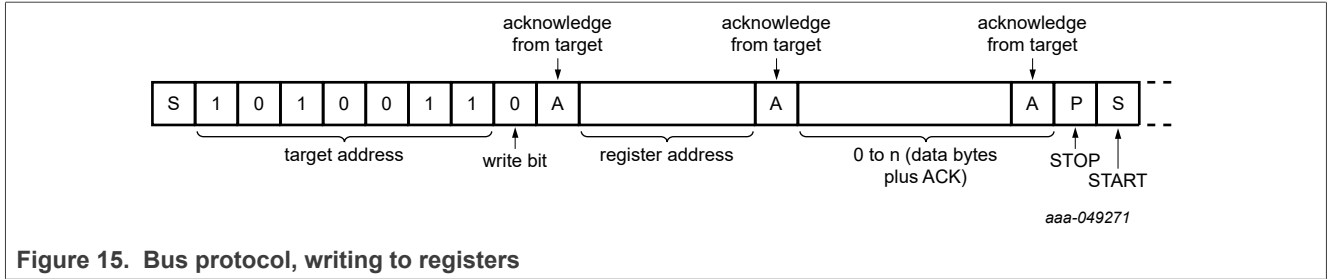

### 7.14.6 I<sup>2</sup>C-bus timeout

If the SCL line is held LOW for longer than  $t_{to}$  (25 ms minimum; 35 ms maximum), the device resets to the idle state and waits for a new START condition. This ensures that the device never hangs up the bus if there are conflicts in the transmission sequence.

### 8 Application information

There are two application diagrams. One is with battery (Figure 17) and the other is without battery (Figure 18).

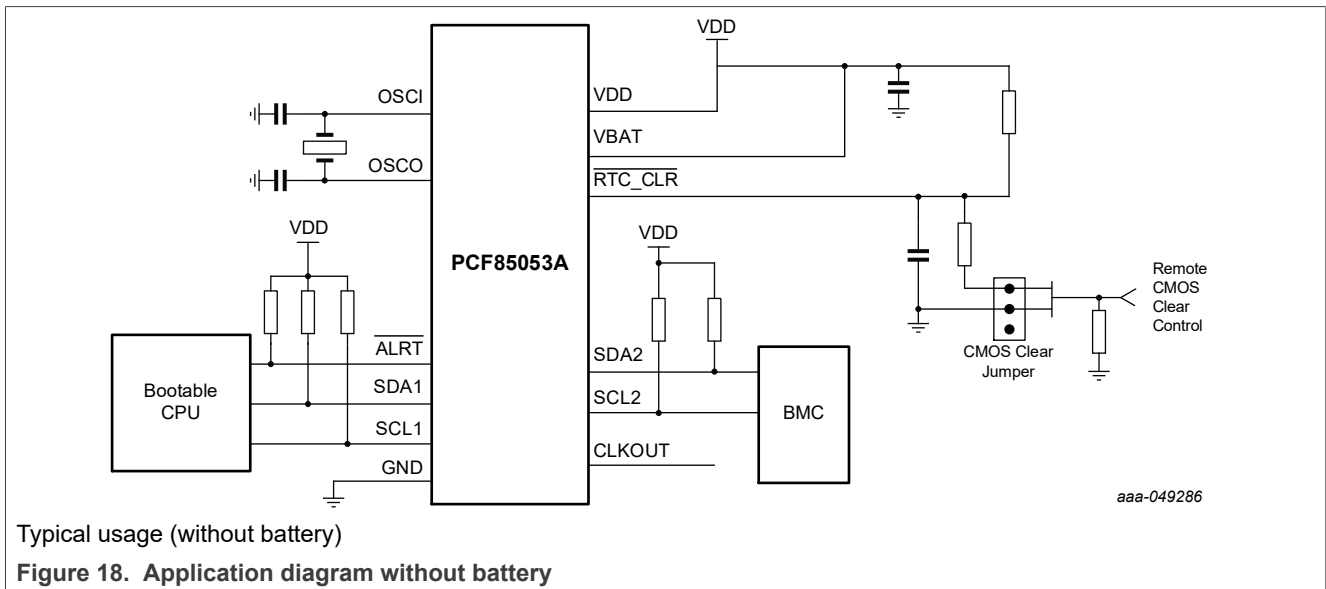
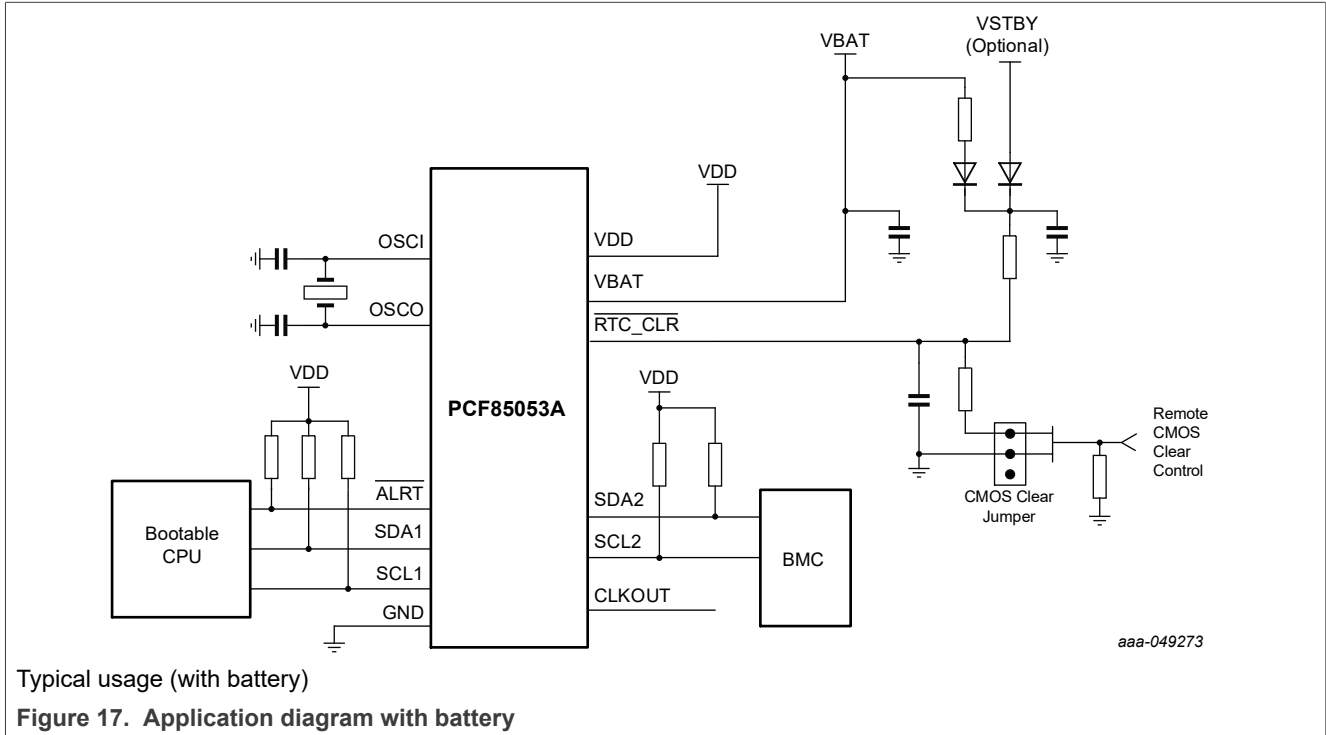

## 9 Limiting values

Table 43. Limiting values

In accordance with the Absolute Maximum Rating System (IEC 60134).

Symbol	Parameter	Conditions	Min	Max	Unit
V <sub>DD</sub>	supply voltage		-0.5	+5.5	V
V <sub>BAT</sub>	battery supply voltage		-0.5	+5.5	V
V <sub>I</sub>	input voltage	SCL, SDA, OSCI, RTC_CLR	-0.5	+5.5	V
V <sub>O</sub>	output voltage		-0.5	+5.5	V
P <sub>tot</sub>	total power dissipation		-	300	mW
V <sub>ESD</sub>	electrostatic discharge voltage	HBM		±2000	V
		CDM		±1000	V
I <sub>lu</sub>	latch-up current	JESD78: -0.5 × V <sub>DD</sub> < V <sub>I</sub> < 1.5 × V <sub>DD</sub> ; T <sub>j</sub> = 85 °C	-100	+100	mA
T <sub>stg</sub>	storage temperature		-65	+150	°C

## 10 Static characteristics

Symbol	Parameter	Conditions	Min	Typ <sup>[1]</sup>	Max	Unit
<b>Supplies</b>						
V <sub>DD</sub>	supply voltage	interface active; f <sub>SCL</sub> = 400 kHz	1.7	-	3.6	V
V <sub>BAT</sub>	battery supply voltage		1.55	-	3.6	V
I <sub>DD</sub>	supply current	CLKOUT disabled; V <sub>DD</sub> = 3.3 V; interface inactive; f <sub>SCL</sub> = 0 Hz				
		T <sub>amb</sub> = 25 °C	-	2	5	µA
		T <sub>amb</sub> = -40 °C to +85 °C	-	5	10	µA
		CLKOUT disabled; V <sub>DD</sub> = 3.3 V; interface active <sup>[1]</sup> ; f <sub>SCL</sub> = 400 kHz		12		µA
		V <sub>DD</sub> = 3.3 V, T <sub>amb</sub> = 25 °C interface active <sup>[1]</sup> ; f <sub>SCL</sub> = 400 kHz and all features are active.	-	-	1	mA
I <sub>BAT</sub>	battery supply current	V <sub>DD</sub> = 0 V V <sub>BAT</sub> = 3.3V				
		T <sub>amb</sub> = 25 °C	-	630	1,050	nA
		T <sub>amb</sub> = -40 °C to +85 °C	-	720	1,200	nA
<b>Reference voltage</b>						

Symbol	Parameter	Conditions	Min	Typ <sup>[1]</sup>	Max	Unit
V <sub>th</sub>	threshold voltage of V <sub>DD</sub> switch-over to V <sub>bat</sub>	falling V <sub>DD</sub>	1.1	1.4	1.5	V
		rising V <sub>DD</sub>	1.25	1.55	1.65	V
		reference voltage hysteresis	-	±50	-	mV
<b>Inputs</b>						
V <sub>I</sub>	input voltage		-0.5	-	+3.6	V
V <sub>IL</sub>	LOW-level input voltage			-	+0.3 V <sub>DD</sub>	V
V <sub>IH</sub>	HIGH-level input voltage		0.7 V <sub>DD</sub>	-		V
I <sub>LI</sub>	input leakage current	V <sub>I</sub> = V <sub>SS</sub> or V <sub>DD</sub>	-	0	-	µA
		post ESD event	-0.5	-	+0.5	µA
V <sub>IL_CLR</sub>	LOW-level input voltage of $\overline{\text{RTC\_CLR}}$		-0.3		+0.5	V
V <sub>IH_CLR</sub>	HIGH-level input voltage of $\overline{\text{RTC\_CLR}}$		1.2		+3.6	V
t <sub>RTC_CLR</sub>	$\overline{\text{RTC\_CLR}}$ Minimum Assertion Windows		32			µs
C <sub>i</sub>	input capacitance		-	-	7	pF
<b>Outputs</b>						
V <sub>OH</sub>	HIGH-level output voltage	on pin CLKOUT	0.8 V <sub>DD</sub>	-	V <sub>DD</sub>	V
V <sub>OL</sub>	LOW-level output voltage	on pins SDA, $\overline{\text{ALRT}}$ , CLKOUT	0	-	0.2 V <sub>DD</sub>	V
I <sub>OH</sub>	HIGH-level output current	output source current; V <sub>OH</sub> = 2.9 V; V <sub>DD</sub> = 3.3 V; on pin CLKOUT	1	3		mA
I <sub>OL</sub>	LOW-level output current	output sink current; V <sub>OL</sub> = 0.4 V; V <sub>DD</sub> = 3.3 V				
		on pin SDA, $\overline{\text{ALRT}}$	3	8.5	-	mA
		on pin CLKOUT	1	3	-	mA
<b>Oscillator</b>						
Dfosc/fosc	relative oscillator frequency variation	ΔV <sub>DD</sub> = 200 mV; T <sub>amb</sub> = 25 °C	-	0.075	-	ppm

Symbol	Parameter	Conditions	Min	Typ <sup>[1]</sup>	Max	Unit
t <sub>jitter</sub>	jitter time	LOWJ = 0	-	50	-	ns
		LOWJ = 1	-	25	-	ns
C <sub>L(itg)</sub>	integrated load capacitance	on pins OSC0, OSC1; V <sub>DD</sub> = 3.3 V				
		C <sub>L</sub> = 6 pF	4.8	6	7.2	pF
		C <sub>L</sub> = 7 pF	5.6	7	8.4	pF
		C <sub>L</sub> = 12.5 pF (default)	10	12.5	15	pF
R <sub>S</sub>	series resistance	normal mode	-	-	100	kΩ

[1] Interface active: The two I<sup>2</sup>C buses read time registers (00h to 09h) independently once per second.

## 11 Dynamic characteristics

Table 44. I<sup>2</sup>C-bus interface dynamic characteristics

All timing characteristics are valid within the operating supply voltage and ambient temperature range and reference to 30 % and 70 % with an input voltage swing of V<sub>SS</sub> to V<sub>DD</sub> (see [Figure 19](#)). These specifications are guaranteed by design and not tested in production.

Symbol	Parameter	Conditions	Fast Mode		Unit
			Min	Max	
<b>Pin SCL</b>					
f <sub>SCL</sub>	SCL clock frequency,	[1]	1	400	kHz
t <sub>LOW</sub>	LOW period of the SCL clock	-	1.3	-	μs
t <sub>HIGH</sub>	HIGH period of the SCL clock	-	0.6	-	μs
t <sub>to</sub>	SMBus SCL time-out time	-	25	35	ms
<b>Pin SDA</b>					
t <sub>SU,DAT</sub>	data set-up time	-	100	-	ns
t <sub>HD,DAT</sub>	data hold time	-	0	-	ns
<b>Pins SCL and SDA</b>					
t <sub>BUF</sub>	bus free time between a STOP and START condition	-	1.3	-	μs
t <sub>SU,STO</sub>	set-up time for STOP condition	-	0.6	-	μs
t <sub>HD,STA</sub>	hold time (repeated) START	-	0.6	-	μs
t <sub>SU,STA</sub>	set-up time for a repeated START condition	-	0.6	-	μs
t <sub>r</sub>	rise time of both SDA and SCL signals	[2] [3]	20 + 0.1Cb	300	ns
t <sub>f</sub>	fall time of both SDA and SCL signals	[2] [3]	20 + 0.1Cb	300	ns
C <sub>b</sub>	capacitive load for each bus line	-	-	400	pF
t <sub>VD,ACK</sub>	data valid acknowledge time	[4]	-	0.9	μs
t <sub>VD,DAT</sub>	data valid time	[5]	-	0.9	μs



Table 44. I<sup>2</sup>C-bus interface dynamic characteristics...continued

All timing characteristics are valid within the operating supply voltage and ambient temperature range and reference to 30 % and 70 % with an input voltage swing of V<sub>SS</sub> to V<sub>DD</sub> (see Figure 19). These specifications are guaranteed by design and not tested in production.

t <sub>SP</sub>	pulse width of spikes that must be suppressed by the input filter	[6]	-	50	ns
-----------------	-------------------------------------------------------------------	-----	---	----	----

- [1] The minimum SCL clock frequency is limited by the bus time-out feature, which resets the serial bus interface if either the SDA or SCL is held LOW for a minimum of 25 ms. The bus time-out feature must be disabled for DC operation.
- [2] A controller device must internally provide a hold time of at least 300 ns for the SDA signal (refer to the VIL of the SCL signal) in order to bridge the undefined region of the falling edge of SCL.
- [3] The maximum t<sub>f</sub> for the SDA and SCL bus lines is 300 ns. The maximum fall time for the SDA output stage, t<sub>f</sub> is 250 ns. This allows series protection resistors to be connected between the SDA pin, the SCL pin and the SDA/SCL bus lines without exceeding the maximum t<sub>f</sub>.
- [4] t<sub>VD;ACK</sub> = time for acknowledgement signal from SCL LOW to SDA output LOW.
- [5] t<sub>VD;DAT</sub> = minimum time for valid SDA output following SCL LOW.
- [6] Input filters on the SDA and SCL inputs suppress noise spikes of less than 50 ns.

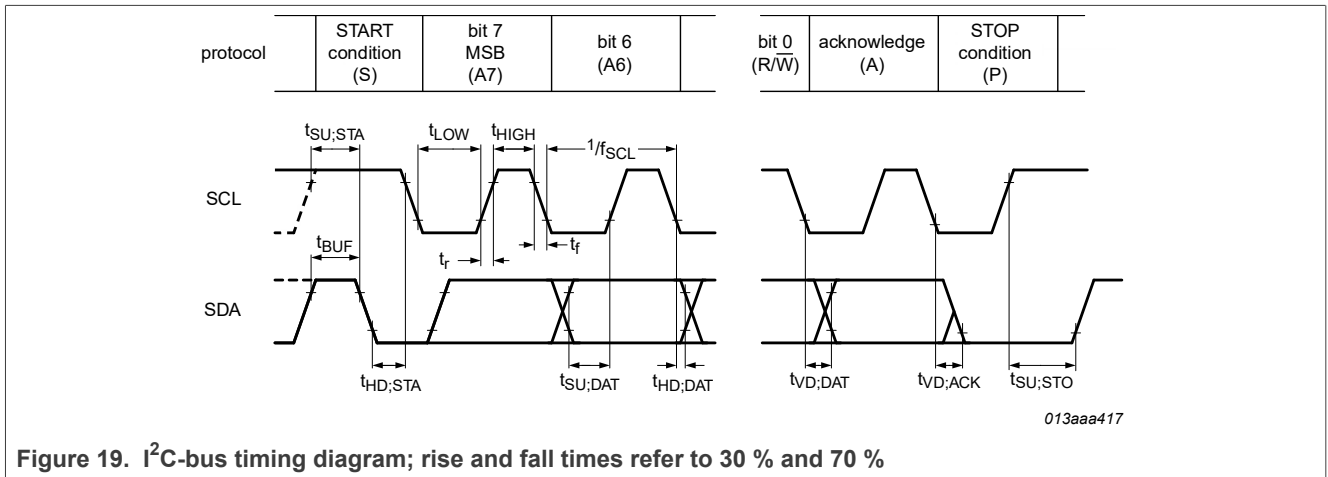
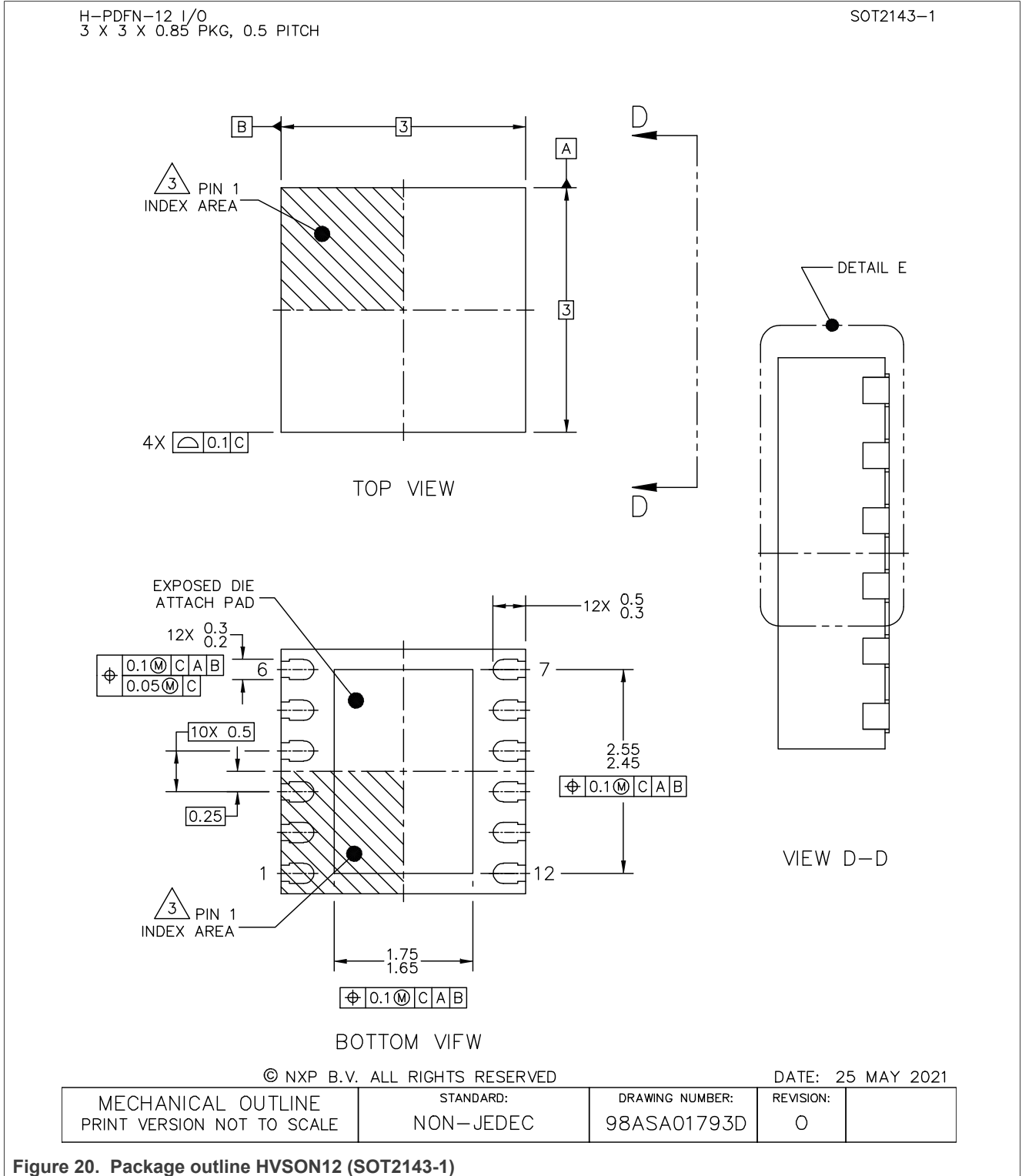

Figure 19. I<sup>2</sup>C-bus timing diagram; rise and fall times refer to 30 % and 70 %

12 Package outline



H-PDFN-12 I/O  
3 X 3 X 0.85 PKG, 0.5 PITCH

SOT2143-1

NOTES:

1. ALL DIMENSIONS ARE IN MILLIMETERS.
2. DIMENSIONING AND TOLERANCING PER ASME Y14.5M-1994.
3. PIN 1 FEATURE SHAPE, SIZE AND LOCATION MAY VARY.
4. COPLANARITY APPLIES TO LEADS, DIE ATTACH FLAG.
5. MIN. METAL GAP FOR LEAD TO EXPOSED PAD SHALL BE 0.2 MM.

© NXP B.V. ALL RIGHTS RESERVED

DATE: 25 MAY 2021

MECHANICAL OUTLINE PRINT VERSION NOT TO SCALE	STANDARD: NON-JEDEC	DRAWING NUMBER: 98ASA01793D	REVISION: 0	
--------------------------------------------------	------------------------	--------------------------------	----------------	--

Figure 21. Package outline HVSON12 (SOT2143-1)

### 13 Soldering PCB footprints

Footprint information for reflow soldering of HVSON12 package.

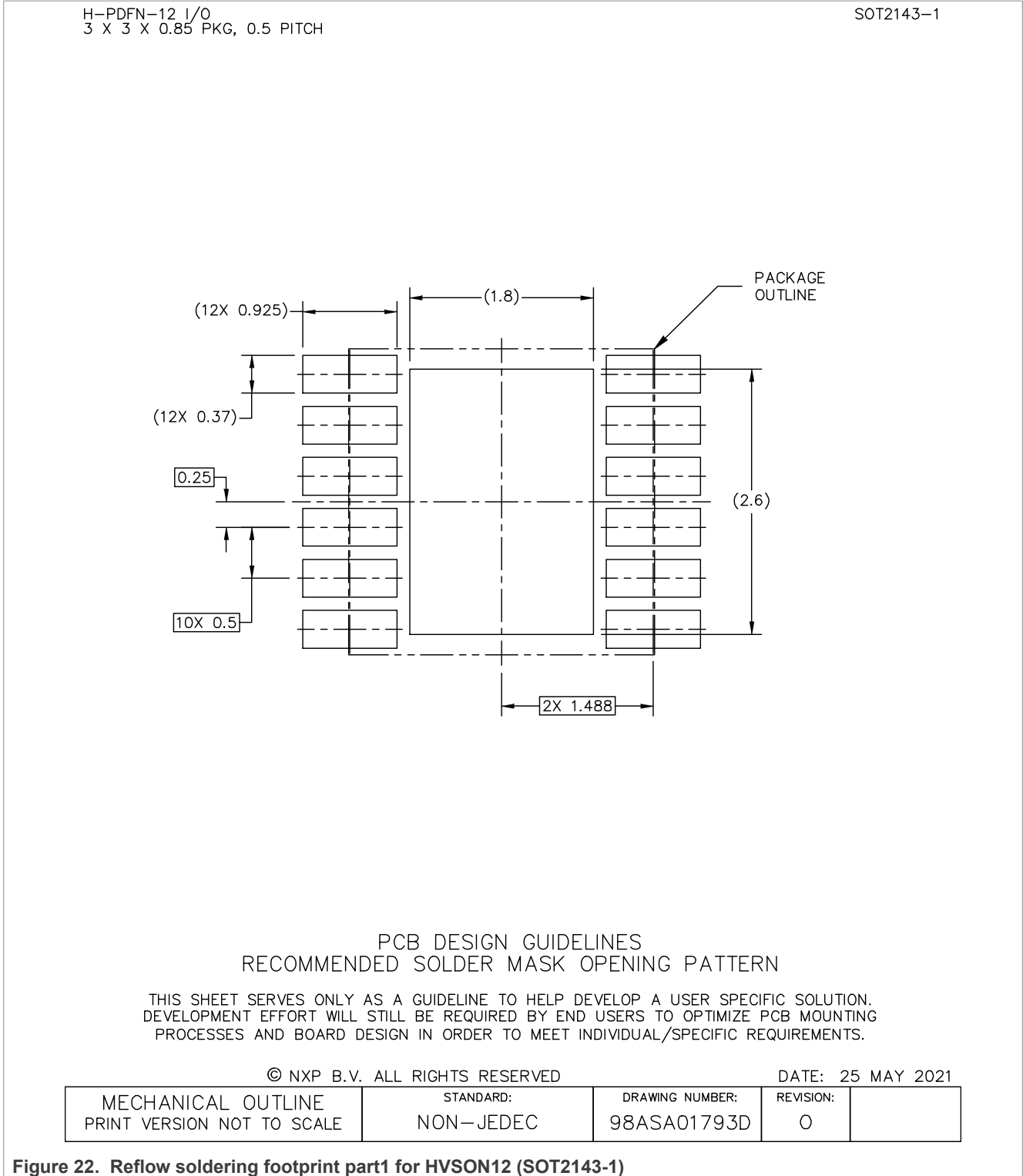

H-PDFN-12 I/O  
3 X 3 X 0.85 PKG, 0.5 PITCH

SOT2143-1

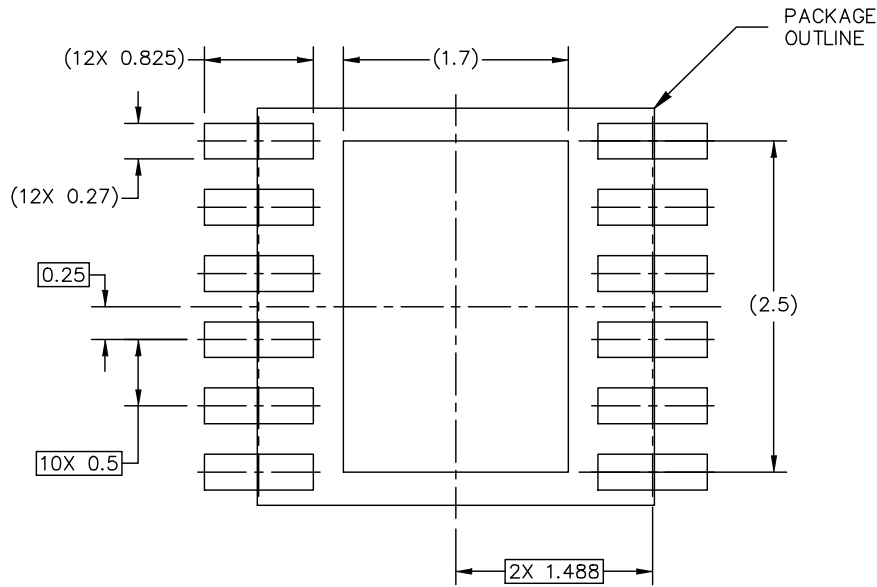

PCB DESIGN GUIDELINES  
RECOMMENDED I/O PADS AND SOLDERABLE AREA

THIS SHEET SERVES ONLY AS A GUIDELINE TO HELP DEVELOP A USER SPECIFIC SOLUTION. DEVELOPMENT EFFORT WILL STILL BE REQUIRED BY END USERS TO OPTIMIZE PCB MOUNTING PROCESSES AND BOARD DESIGN IN ORDER TO MEET INDIVIDUAL/SPECIFIC REQUIREMENTS.

© NXP B.V. ALL RIGHTS RESERVED

DATE: 25 MAY 2021

MECHANICAL OUTLINE PRINT VERSION NOT TO SCALE	STANDARD: NON-JEDEC	DRAWING NUMBER: 98ASA01793D	REVISION: 0	
--------------------------------------------------	------------------------	--------------------------------	----------------	--

Figure 23. Reflow soldering footprint part2 for HVSON12 (SOT2143-1)

H-PDFN-12, I/O  
3 X 3 X 0.85 PKG, 0.5 PITCH

SOT2143-1

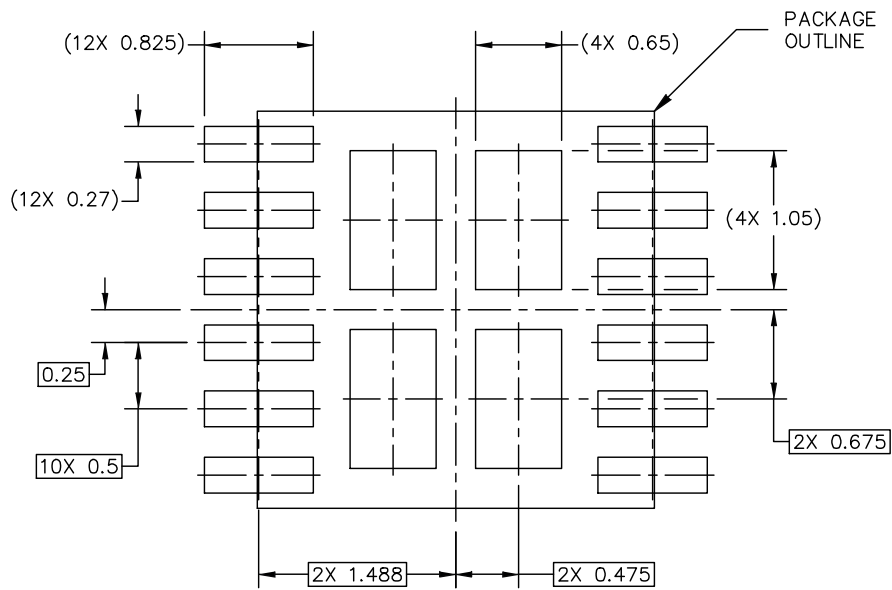

RECOMMENDED STENCIL THICKNESS 0.125 OR 0.150

PCB DESIGN GUIDELINES – RECOMMENDED SOLDER PASTE STENCIL

THIS SHEET SERVES ONLY AS A GUIDELINE TO HELP DEVELOP A USER SPECIFIC SOLUTION. DEVELOPMENT EFFORT WILL STILL BE REQUIRED BY END USERS TO OPTIMIZE PCB MOUNTING PROCESSES AND BOARD DESIGN IN ORDER TO MEET INDIVIDUAL/SPECIFIC REQUIREMENTS.

© NXP B.V. ALL RIGHTS RESERVED

DATE: 25 MAY 2021

MECHANICAL OUTLINE PRINT VERSION NOT TO SCALE	STANDARD: NON-JEDEC	DRAWING NUMBER: 98ASA01793D	REVISION: 0	
--------------------------------------------------	------------------------	--------------------------------	----------------	--

Figure 24. Reflow soldering footprint part3 for HVSON12 (SOT2143-1)

## 14 Revision history

Table 45. Revision history

Document ID	Release date	Data sheet status	Change notice	Supersedes
PCF85053A v.1.0	20230131	Product data sheet	-	-

## 15 Legal information

### 15.1 Data sheet status

Document status <sup>[1][2]</sup>	Product status <sup>[3]</sup>	Definition
Objective [short] data sheet	Development	This document contains data from the objective specification for product development.
Preliminary [short] data sheet	Qualification	This document contains data from the preliminary specification.
Product [short] data sheet	Production	This document contains the product specification.

[1] Please consult the most recently issued document before initiating or completing a design.

[2] The term 'short data sheet' is explained in section "Definitions".

[3] The product status of device(s) described in this document may have changed since this document was published and may differ in case of multiple devices. The latest product status information is available on the Internet at URL <http://www.nxp.com>.

### 15.2 Definitions

**Draft** — A draft status on a document indicates that the content is still under internal review and subject to formal approval, which may result in modifications or additions. NXP Semiconductors does not give any representations or warranties as to the accuracy or completeness of information included in a draft version of a document and shall have no liability for the consequences of use of such information.

**Short data sheet** — A short data sheet is an extract from a full data sheet with the same product type number(s) and title. A short data sheet is intended for quick reference only and should not be relied upon to contain detailed and full information. For detailed and full information see the relevant full data sheet, which is available on request via the local NXP Semiconductors sales office. In case of any inconsistency or conflict with the short data sheet, the full data sheet shall prevail.

**Product specification** — The information and data provided in a Product data sheet shall define the specification of the product as agreed between NXP Semiconductors and its customer, unless NXP Semiconductors and customer have explicitly agreed otherwise in writing. In no event however, shall an agreement be valid in which the NXP Semiconductors product is deemed to offer functions and qualities beyond those described in the Product data sheet.

### 15.3 Disclaimers

**Limited warranty and liability** — Information in this document is believed to be accurate and reliable. However, NXP Semiconductors does not give any representations or warranties, expressed or implied, as to the accuracy or completeness of such information and shall have no liability for the consequences of use of such information. NXP Semiconductors takes no responsibility for the content in this document if provided by an information source outside of NXP Semiconductors.

In no event shall NXP Semiconductors be liable for any indirect, incidental, punitive, special or consequential damages (including - without limitation - lost profits, lost savings, business interruption, costs related to the removal or replacement of any products or rework charges) whether or not such damages are based on tort (including negligence), warranty, breach of contract or any other legal theory.

Notwithstanding any damages that customer might incur for any reason whatsoever, NXP Semiconductors' aggregate and cumulative liability towards customer for the products described herein shall be limited in accordance with the Terms and conditions of commercial sale of NXP Semiconductors.

**Right to make changes** — NXP Semiconductors reserves the right to make changes to information published in this document, including without limitation specifications and product descriptions, at any time and without notice. This document supersedes and replaces all information supplied prior to the publication hereof.

**Suitability for use** — NXP Semiconductors products are not designed, authorized or warranted to be suitable for use in life support, life-critical or safety-critical systems or equipment, nor in applications where failure or malfunction of an NXP Semiconductors product can reasonably be expected to result in personal injury, death or severe property or environmental damage. NXP Semiconductors and its suppliers accept no liability for inclusion and/or use of NXP Semiconductors products in such equipment or applications and therefore such inclusion and/or use is at the customer's own risk.

**Applications** — Applications that are described herein for any of these products are for illustrative purposes only. NXP Semiconductors makes no representation or warranty that such applications will be suitable for the specified use without further testing or modification.

Customers are responsible for the design and operation of their applications and products using NXP Semiconductors products, and NXP Semiconductors accepts no liability for any assistance with applications or customer product design. It is customer's sole responsibility to determine whether the NXP Semiconductors product is suitable and fit for the customer's applications and products planned, as well as for the planned application and use of customer's third party customer(s). Customers should provide appropriate design and operating safeguards to minimize the risks associated with their applications and products.

NXP Semiconductors does not accept any liability related to any default, damage, costs or problem which is based on any weakness or default in the customer's applications or products, or the application or use by customer's third party customer(s). Customer is responsible for doing all necessary testing for the customer's applications and products using NXP Semiconductors products in order to avoid a default of the applications and the products or of the application or use by customer's third party customer(s). NXP does not accept any liability in this respect.

**Limiting values** — Stress above one or more limiting values (as defined in the Absolute Maximum Ratings System of IEC 60134) will cause permanent damage to the device. Limiting values are stress ratings only and (proper) operation of the device at these or any other conditions above those given in the Recommended operating conditions section (if present) or the Characteristics sections of this document is not warranted. Constant or repeated exposure to limiting values will permanently and irreversibly affect the quality and reliability of the device.

**Terms and conditions of commercial sale** — NXP Semiconductors products are sold subject to the general terms and conditions of commercial sale, as published at <http://www.nxp.com/profile/terms>, unless otherwise agreed in a valid written individual agreement. In case an individual agreement is concluded only the terms and conditions of the respective agreement shall apply. NXP Semiconductors hereby expressly objects to applying the customer's general terms and conditions with regard to the purchase of NXP Semiconductors products by customer.

**No offer to sell or license** — Nothing in this document may be interpreted or construed as an offer to sell products that is open for acceptance or the grant, conveyance or implication of any license under any copyrights, patents or other industrial or intellectual property rights.



**Quick reference data** — The Quick reference data is an extract of the product data given in the Limiting values and Characteristics sections of this document, and as such is not complete, exhaustive or legally binding.

**Export control** — This document as well as the item(s) described herein may be subject to export control regulations. Export might require a prior authorization from competent authorities.

**Suitability for use in non-automotive qualified products** — Unless this data sheet expressly states that this specific NXP Semiconductors product is automotive qualified, the product is not suitable for automotive use. It is neither qualified nor tested in accordance with automotive testing or application requirements. NXP Semiconductors accepts no liability for inclusion and/or use of non-automotive qualified products in automotive equipment or applications.

In the event that customer uses the product for design-in and use in automotive applications to automotive specifications and standards, customer (a) shall use the product without NXP Semiconductors' warranty of the product for such automotive applications, use and specifications, and (b) whenever customer uses the product for automotive applications beyond NXP Semiconductors' specifications such use shall be solely at customer's own risk, and (c) customer fully indemnifies NXP Semiconductors for any liability, damages or failed product claims resulting from customer design and use of the product for automotive applications beyond NXP Semiconductors' standard warranty and NXP Semiconductors' product specifications.

**Translations** — A non-English (translated) version of a document, including the legal information in that document, is for reference only. The English version shall prevail in case of any discrepancy between the translated and English versions.

**Security** — Customer understands that all NXP products may be subject to unidentified vulnerabilities or may support established security standards or specifications with known limitations. Customer is responsible for the design and operation of its applications and products throughout their lifecycles to reduce the effect of these vulnerabilities on customer's applications and products. Customer's responsibility also extends to other open and/or proprietary technologies supported by NXP products for use in customer's applications. NXP accepts no liability for any vulnerability. Customer should regularly check security updates from NXP and follow up appropriately.

Customer shall select products with security features that best meet rules, regulations, and standards of the intended application and make the ultimate design decisions regarding its products and is solely responsible for compliance with all legal, regulatory, and security related requirements concerning its products, regardless of any information or support that may be provided by NXP.

NXP has a Product Security Incident Response Team (PSIRT) (reachable at [PSIRT@nxp.com](mailto:PSIRT@nxp.com)) that manages the investigation, reporting, and solution release to security vulnerabilities of NXP products.

## 15.4 Trademarks

Notice: All referenced brands, product names, service names, and trademarks are the property of their respective owners.

**NXP** — wordmark and logo are trademarks of NXP B.V.

## Tables

Tab. 1.	Ordering information .....	2	Tab. 25.	Version, Vendor and Part number register byte .....	17
Tab. 2.	Ordering options .....	2	Tab. 26.	Offset - offset register byte (default value : 00h) .....	17
Tab. 3.	Pin description of PCF85053A .....	4	Tab. 27.	Offset registers read/write capability by the two I2C buses .....	17
Tab. 4.	Device addresses of RTC and SRAM .....	5	Tab. 28.	OFFM bit - oscillator control register (address 13h) .....	18
Tab. 5.	RTC register map .....	6	Tab. 29.	Offset values .....	18
Tab. 6.	RTC Register read/write capability by the two I2C buses .....	7	Tab. 30.	Correction pulses for OFFM = 0 .....	19
Tab. 7.	RTC Read only registers .....	8	Tab. 31.	Correction pulses for OFFM = 1 .....	19
Tab. 8.	SRAM register map .....	8	Tab. 32.	Oscillator register byte .....	21
Tab. 9.	SRAM registers read/write capability by the two I2C buses .....	9	Tab. 33.	Oscillator register read/write capability configuration .....	21
Tab. 10.	Time register map .....	9	Tab. 34.	Oscillator register bit detail (default value: 00h) .....	21
Tab. 11.	Time registers read/write capability configuration .....	9	Tab. 35.	Access – access control register byte .....	23
Tab. 12.	BCD format .....	10	Tab. 36.	Access registers read/write capability configuration .....	23
Tab. 13.	Alarm registers .....	11	Tab. 37.	Access register bit detail (default value: 00h) .....	23
Tab. 14.	Control, status, CLKOUT, and 2nd control registers read/write capability configuration .....	12	Tab. 38.	XCLK bit detail (default value: 0) .....	23
Tab. 15.	Control register byte .....	12	Tab. 39.	Timestamp registers .....	23
Tab. 16.	Control register bit detail .....	12	Tab. 40.	SRAM register map .....	24
Tab. 17.	First increment of time circuits after ST bit release .....	14	Tab. 41.	SRAM registers read/write capability by the two I2C buses .....	25
Tab. 18.	Status register byte .....	15	Tab. 42.	I2C target address byte .....	26
Tab. 19.	Status register bit detail .....	15	Tab. 43.	Limiting values .....	30
Tab. 20.	CLKOUT Control register byte .....	16	Tab. 44.	I2C-bus interface dynamic characteristics .....	32
Tab. 21.	Status register bit detail .....	16	Tab. 45.	Revision history .....	39
Tab. 22.	2nd Control register byte .....	16			
Tab. 23.	2nd control register bit detail .....	17			
Tab. 24.	Scratchpad register byte .....	17			

## Figures

Fig. 1.	Block diagram of PCF85053A .....	3	Fig. 15.	Bus protocol, writing to registers .....	28
Fig. 2.	Pin configuration .....	4	Fig. 16.	Bus protocol, reading from registers .....	28
Fig. 3.	Address register incrementing .....	5	Fig. 17.	Application diagram with battery .....	29
Fig. 4.	Data flow for the time function .....	11	Fig. 18.	Application diagram without battery .....	29
Fig. 5.	ST bit functional diagram .....	13	Fig. 19.	I2C-bus timing diagram; rise and fall times refer to 30 % and 70 % .....	33
Fig. 6.	ST bit release timing .....	13	Fig. 20.	Package outline HVSON12 (SOT2143-1) .....	34
Fig. 7.	OF flag .....	16	Fig. 21.	Package outline HVSON12 (SOT2143-1) .....	35
Fig. 8.	Offset calibration calculation workflow .....	20	Fig. 22.	Reflow soldering footprint part1 for HVSON12 (SOT2143-1) .....	36
Fig. 9.	Result of offset calibration .....	21	Fig. 23.	Reflow soldering footprint part2 for HVSON12 (SOT2143-1) .....	37
Fig. 10.	SRAM register incrementing .....	24	Fig. 24.	Reflow soldering footprint part3 for HVSON12 (SOT2143-1) .....	38
Fig. 11.	Bit transfer .....	25			
Fig. 12.	Definition of START and STOP conditions .....	25			
Fig. 13.	System configuration .....	26			
Fig. 14.	Acknowledgement on the I2C-bus .....	26			