

Features

- Rated current on primary up to 20 A for PCS020, up to 40 A for PCS040
- Surface mount
- Frequency up to 1 MHz
- Operating temp: -40 °C to 125 °C
- RoHS compliant*

Applications

- Switched-mode power supplies
- Motor control
- Overload sensing
- AC current applications

PCS Series Current Sense Transformers

General Specifications

Operating Temperature.....	-40 °C to +125 °C
Isolation Between Windings	
PCS020.....	500 V _{rms}
PCS040.....	800 V _{rms}
Rated current on primary	
PCS020.....	Up to 20 A (10 A typical)
PCS040.....	Up to 40 A
Frequency.....	Up to 1 MHz
Moisture Sensitivity Level.....	1

Additional Information

Click these links for more information:



Electrical Specifications @ 25 °C

Bourns Part Number	Turns Ratio Primary : Secondary	Secondary Inductance Min. (mH)	DCR		Volt-time Product on Secondary Max. (V-µsec)	Terminating Resistance (1 V Output at Rated Current) (Ω)
			Primary Ref. (mΩ)	Secondary Max. (Ω)		
PCS020-EE05081S	1 : 20	81	7	0.4	10.8	1
PCS020-EE05180S	1 : 30	180	7	0.87	16.2	1.5
PCS020-EE05320S	1 : 40	320	7	1.14	21.6	2
PCS020-EE05500S	1 : 50	500	7	1.5	27	2.5
PCS020-EE05730S	1 : 60	730	7	1.98	32.4	3
PCS020-EE05980S	1 : 70	980	7	4.75	37.8	3.5
PCS020-EE0502KS	1 : 100	2000	7	5.5	54	5
PCS020-EE0503KS	1 : 125	3000	7	7	67.5	6.25
PCS040-EF13340S	1 : 20	0.34	1	0.18	50.8	0.5
PCS040-EF13760S	1 : 30	0.76	1	0.265	76.2	0.8
PCS040-EF1301KS	1 : 40	1.36	1	0.56	101.6	1
PCS040-EF1302KS	1 : 50	2.12	1	0.705	127	1.3
PCS040-EF1303KS	1 : 60	3.06	1	0.85	152.4	1.5
PCS040-EF1304KS	1 : 70	4.16	1	1	177.8	1.8
PCS040-EF1305KS	1 : 80	5.44	1	1.15	203.2	2
PCS040-EF1308KS	1 : 100	8.5	1	1.45	254	2.5
PCS040-EF1313KS	1 : 125	13.3	1	1.85	317.5	3.1
PCS040-EF1319KS	1 : 150	19.2	1	2.25	381	3.8
PCS040-EF1334KS	1 : 200	34	1	4.06	508	5



WARNING Cancer and Reproductive Harm - www.P65Warnings.ca.gov

* RoHS Directive 2015/863, Mar 31, 2015 and Annex.

Specifications are subject to change without notice.

Users should verify actual device performance in their specific applications.

The products described herein and this document are subject to specific legal disclaimers as set forth on the last page of this document, and at www.bourns.com/docs/legal/disclaimer.pdf.

PCS Series Current Sense Transformers



Product Dimensions

PCS020

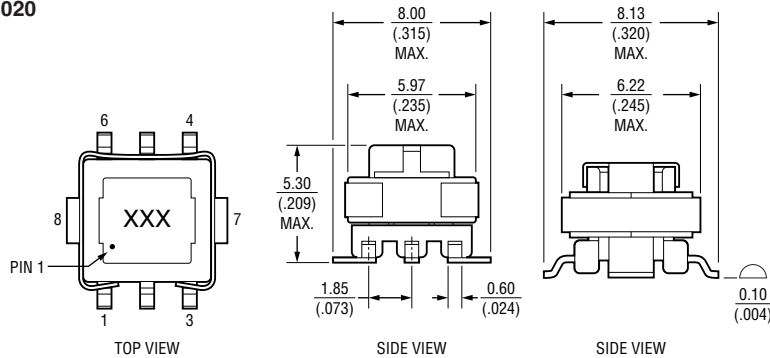

PCS040

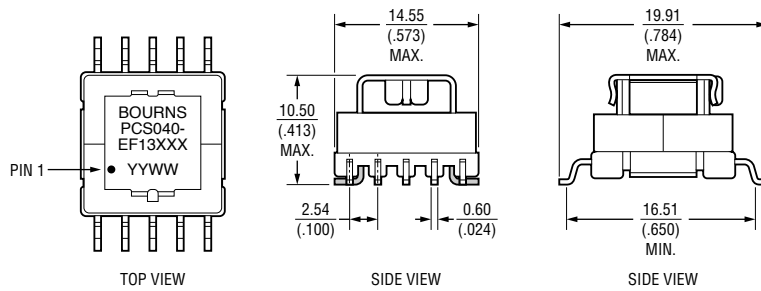

DIMENSIONS: $\frac{\text{MM}}{\text{(INCHES)}}$

Unless otherwise specified, all tolerances are $\pm 0.25 / (.010)$

Application Circuit

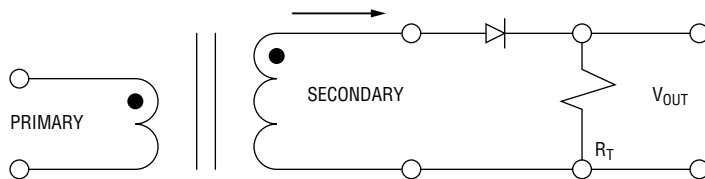

Terminating resistor R_T is based on 1 volt output with the rated current 20 amps for the PCS020 and 40 amps for the PCS040 through the Primary. The terminating resistor can be calculated with the following equation: $R_T = V_{out} * N_{sec} / I_{prim}$.

Materials

Core..... P4
 Bobbin PM9630
 Wire XUEW and UEWH
 Tape..... PI-310
 Glue..... S-9001
 Clip SUS301
 Packaging
 PCS020..... 1000 pcs. per 13-inch reel
 PCS040..... 300 pcs. per 13-inch reel

Typical Part Marking

Bourns Part Number	Marking
PCS020-EE05081S	081
PCS020-EE05180S	180
PCS020-EE05320S	320
PCS020-EE05500S	500
PCS020-EE05730S	730
PCS020-EE05980S	980
PCS020-EE0502KS	02K
PCS020-EE0503KS	03K
PCS040-EF13340S	PCS040-EF13340S
PCS040-EF13760S	PCS040-EF13760S
PCS040-EF1301KS	PCS040-EF1301KS
PCS040-EF1302KS	PCS040-EF1302KS
PCS040-EF1303KS	PCS040-EF1303KS
PCS040-EF1304KS	PCS040-EF1304KS
PCS040-EF1305KS	PCS040-EF1305KS
PCS040-EF1308KS	PCS040-EF1308KS
PCS040-EF1313KS	PCS040-EF1313KS
PCS040-EF1319KS	PCS040-EF1319KS
PCS040-EF1334KS	PCS040-EF1334KS

Electrical Schematic

PCS020



PCS040

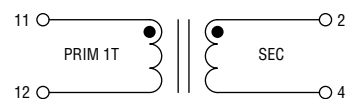

Specifications are subject to change without notice.

Users should verify actual device performance in their specific applications.

The products described herein and this document are subject to specific legal disclaimers as set forth on the last page of this document, and at www.bourns.com/docs/legal/disclaimer.pdf.

PCS Series Current Sense Transformers



How To Order

PCS 020 - EE05 081 S

Model _____
 PCS = Current Sense Transformer

Rated Current _____
 020 = 20 A
 040 = 40 A

Bobbin Size _____
 EE05 = Bobbin EE5
 EF13 = Bobbin EF12.6

Inductance (see table) _____
 081 = 81 μ H

PCB type _____
 S = SMD

Soldering Profile

The duration from room temperature (25 °C) to peak temperature is 8 minutes maximum.

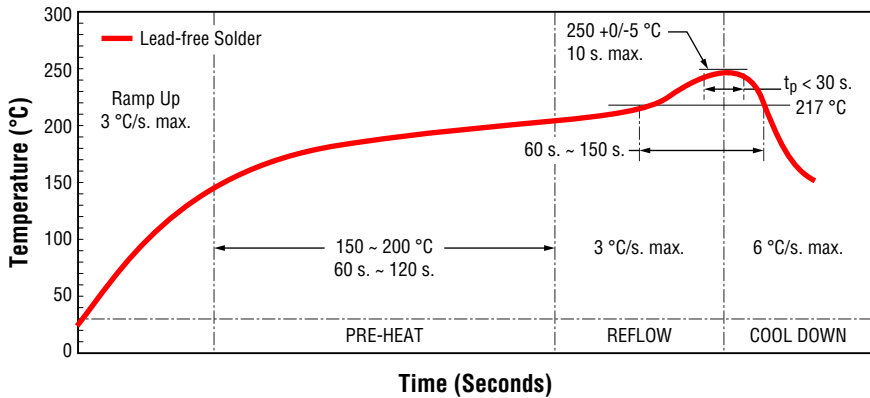

Recommended Layout

PCS020

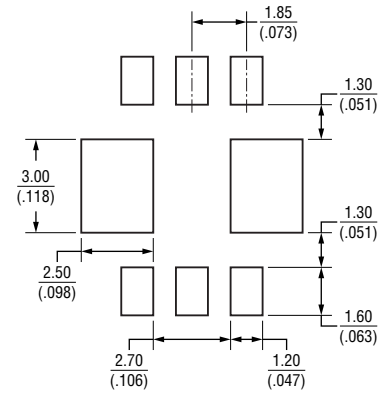

PCS040

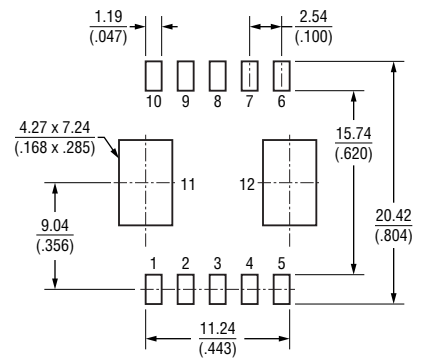

DIMENSIONS: $\frac{\text{MM}}{\text{(INCHES)}}$

Specifications are subject to change without notice.

Users should verify actual device performance in their specific applications.

The products described herein and this document are subject to specific legal disclaimers as set forth on the last page of this document, and at www.bourns.com/docs/legal/disclaimer.pdf.

PCS Series Current Sense Transformers

BOURNS®

Packaging Specifications

PCS020

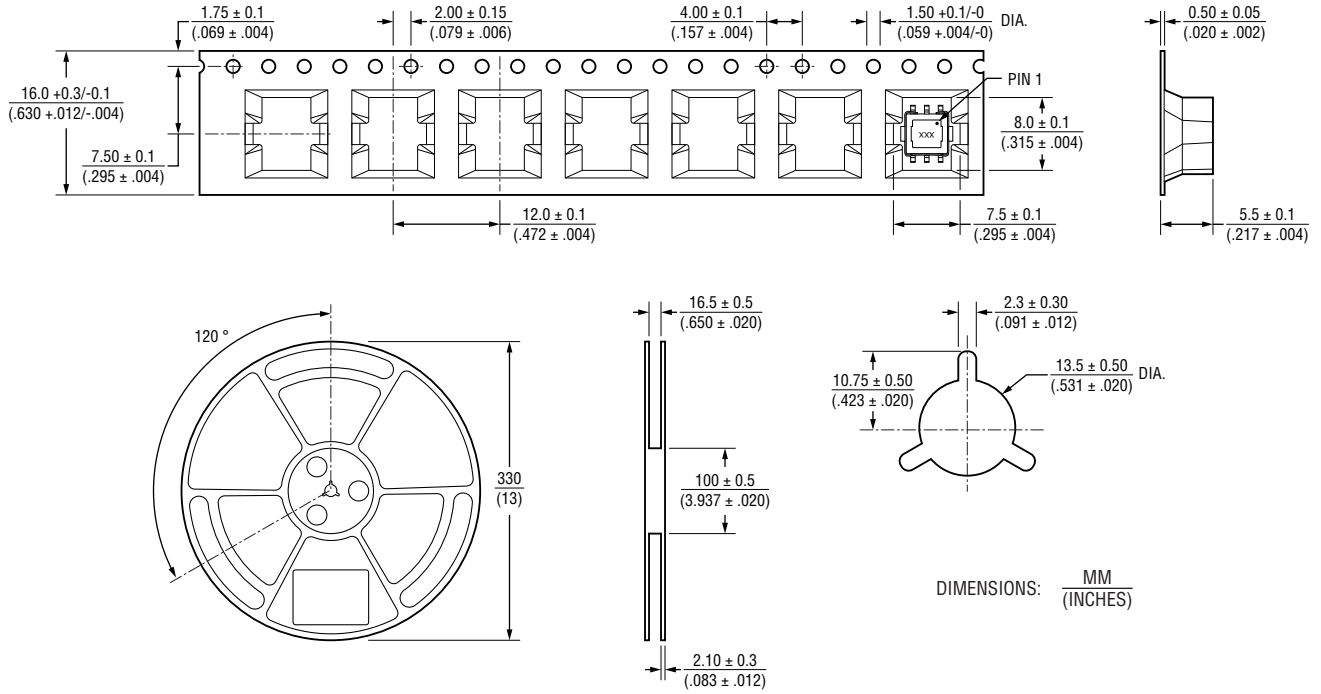

PCS040

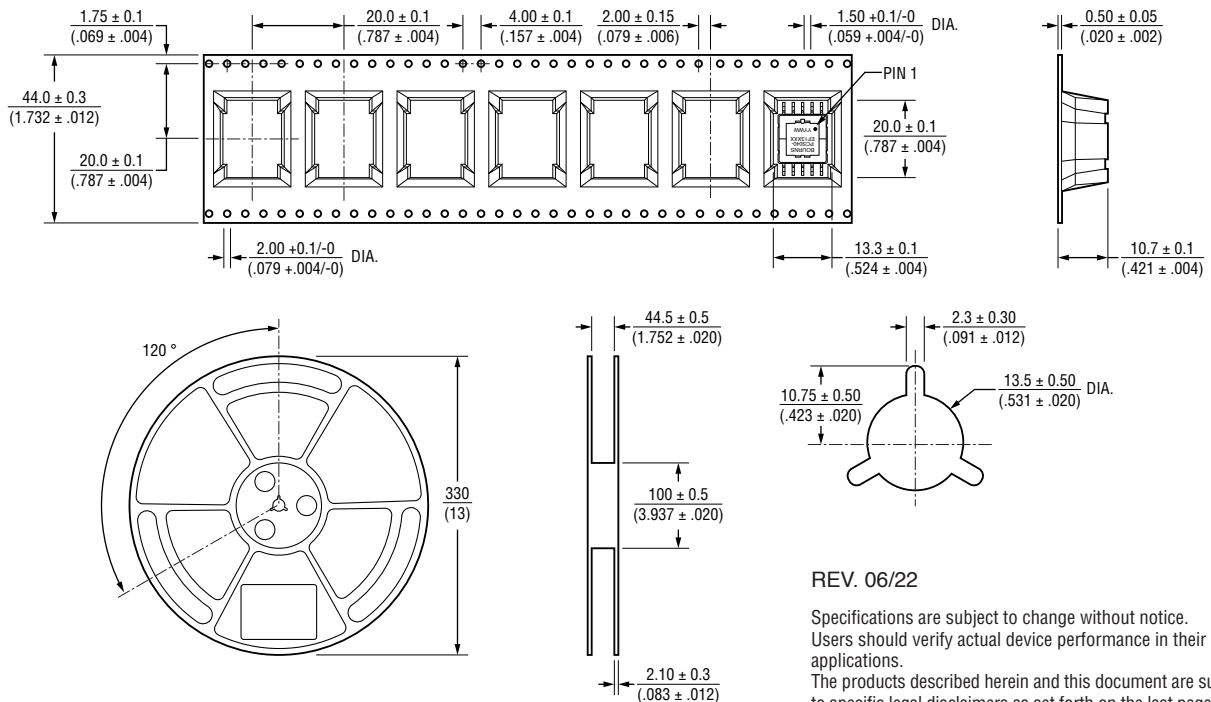

REV. 06/22

Specifications are subject to change without notice. Users should verify actual device performance in their specific applications. The products described herein and this document are subject to specific legal disclaimers as set forth on the last page of this document, and at www.bourns.com/docs/legal/disclaimer.pdf.