

PE53211

Document Category: Product Brief

Dual Channel Switch LNA Module, 2.3 GHz - 2.7 GHz



Features

- Wide frequency range with internal matching
- Integrates dual-channel LNA with bypass and high power switch
- Max RF input power
 - 5W Pavg for long term
 - 10W Pavg for short term
- 1.4 dB noise figure
- 30 dBm OIP3/ 34 dB gain at full gain mode
- +105 °C operating temperature
- Low power consumption: 90 mA per channel
- Compact package size of 32-lead 5x5 mm

Applications

- 4G/4.5G TD-LTE macro/micro cell
- Pre-5G/5G massive MIMO systems
- Receiver protection system

Figure 1 ■ PE53211 Functional Diagram

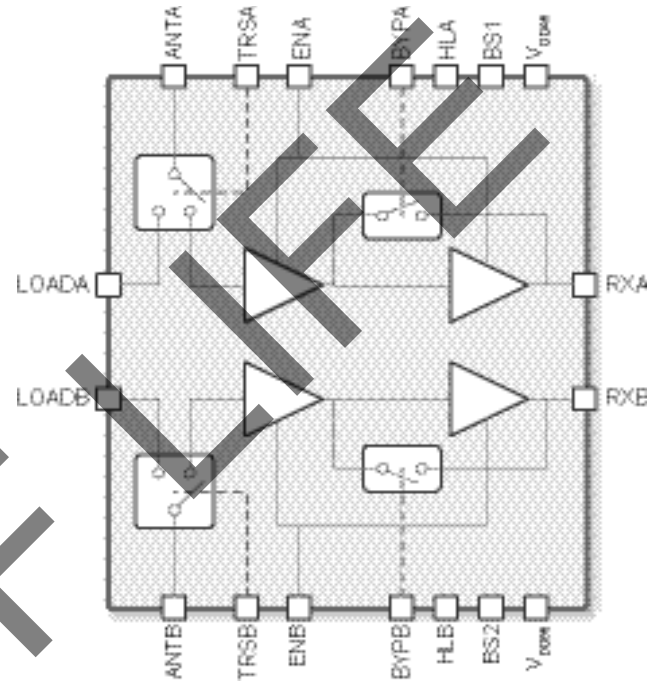

Product Description

The PE53211 is a highly integrated front-end module targeted for wireless infrastructure applications such as TDD macro/micro base stations and MIMO application. It is designed for use at the front end of receiver chain of TDD-based systems. The PE53211 is ideally suited for 4G or next-generation 5G solutions, or small cell applications.

The dual-channel receiver integrates two independent LNAs with bypass function and a high power switch. The PE53211 can be utilized across the 2.3–2.7 GHz frequency range with internal impedance matching networks.

This receiver utilizes pSemi's UltraCMOS SOI technology which supports input RF power signal up to 5W average power, assuming 8 dB PAR and very low noise figure, excellent linearity and very low power consumption. Each channel is controlled individually within the selected frequency band, which allows more flexibility in the system design.

Ordering Information

Table 1 lists the available ordering codes for the PE53211 as well as available shipping methods.

Table 1 ■ Order Codes for PE53211

Order Codes	Description	Packaging	Shipping Method
PE53211A-Z	PE53211 Switch and LNA	32-lead 5x5 mm LGA	3000 units/T&R
EK53211-01	PE53211 Evaluation kit	Evaluation kit	1/Box

Document Categories

Advance Information

The product is in a formative or design stage. The datasheet contains design target specifications for product development. Specifications and features may change in any manner without notice.

Preliminary Specification

The datasheet contains preliminary data. Additional data may be added at a later date. pSemi reserves the right to change specifications at any time without notice in order to supply the best possible product.

Product Specification

The datasheet contains final data. In the event pSemi decides to change the specifications, pSemi will notify customers of the intended changes by issuing a CNF (Customer Notification Form).

Product Brief

The product brief contains summary product information.

Sales Contact

For additional information, contact Sales at sales@psemi.com.

Disclaimers

The information in this document is believed to be reliable. However, pSemi assumes no liability for the use of this information. Use shall be entirely at the user's own risk. No patent rights or licenses to any circuits described in this document are implied or granted to any third party. pSemi's products are not designed or intended for use in devices or systems intended for surgical implant, or in other applications intended to support or sustain life, or in any application in which the failure of the pSemi product could create a situation in which personal injury or death might occur. pSemi assumes no liability for damages, including consequential or incidental damages, arising out of the use of its products in such applications.

Patent Statement

pSemi products are protected under one or more of the following U.S. patents: patents.psemi.com

Copyright and Trademark

©2018, pSemi Corporation. All rights reserved. The Peregrine Semiconductor name, Peregrine Semiconductor logo and UltraCMOS are registered trademarks and the pSemi name, pSemi logo, HaRP and DuNE are trademarks of pSemi Corporation in the U.S. and other countries.