

Features

- Push switch option
- Compact, rugged design
- High reliability
- Metal bushing/shaft
- RoHS compliant*

PEC11R Series - 12 mm Incremental Encoder

Electrical Characteristics

Output 2-bit quadrature code
 Contact Rating 10 mA @ 5 VDC
 Insulation Resistance
 100 megohms @ 250V DC
 Dielectric Withstanding Voltage
 Sea Level 300 VAC min.
 Electrical Travel Continuous
 Contact Bounce (15 RPM) 2.0 ms max.**
 RPM (Operating) 60 max.**

Environmental Characteristics

Operating Temperature Range
 -30 °C to +70 °C (-22 °F to +158 °F)
 Storage Temperature Range
 -40 °C to +85 °C (-40 °F to +185 °F)
 Humidity
 MIL-STD-202, Method 103B, Condition B
 Vibration
 ... 10~55~10 Hz / 1 min. / Amplitude 1.5 mm
 Shock 100 G
 IP Rating IP 40

Mechanical Characteristics

Mechanical Angle 360 ° Continuous
 Torque
 Detent ... 30 to 90 gf-cm (0.41 to 1.25 oz.-in.)
 Running ... 10-70 gf-cm (0.14 to 0.97 oz.-in.)
 Mounting 10.2 kgf-cm (8.83 lb.-in.) max.
 Shaft Side Load (Static)
 2.04 kgf (4.5 lbs.) min.
 Weight 5 gm (0.17 oz.) max.
 Terminals Printed circuit board terminals
 Soldering Condition
 Wave Soldering Sn95.5/Ag2.8/Cu0.7
 solder with no-clean flux: 260 °C max. for
 3 ± 1 sec.
 Hand Soldering Not recommended
 Hardware .. One flat washer and one mounting
 nut supplied with each encoder
 Rotational Life 30,000 cycles min.
 Switch Life 20,000 cycles min.

Switch Characteristics

Switch Type
 Contact Push ON Momentary SPST
 Power Rating (Resistive Load)
 10 mA at 5 VDC
 Switch Travel 0.5 ± 0.3 mm
 Switch Actuation Force
 610 ± 306 gf (8.47 ± 4.24 oz.in.)
 Contact Resistance ... 100 milliohms @ 5 VDC



WARNING
 Cancer and Reproductive Harm
www.P65Warnings.ca.gov

*RoHS Directive 2015/863, Mar 31, 2015 and Annex.
 **Devices are tested using standard noise reduction
 filters. For optimum performance, designers should use
 noise reduction filters in their circuits.
 Specifications are subject to change without notice.
 Users should verify actual device performance in their
 specific applications. The products described herein and
 this document are subject to specific legal disclaimers as
 set forth on the last page of this document, and at
www.bourns.com/docs/legal/disclaimer.pdf.

Additional Information

Click these links for more information:



Product Dimensions

PEC11R-1xxxF-Nxxxx

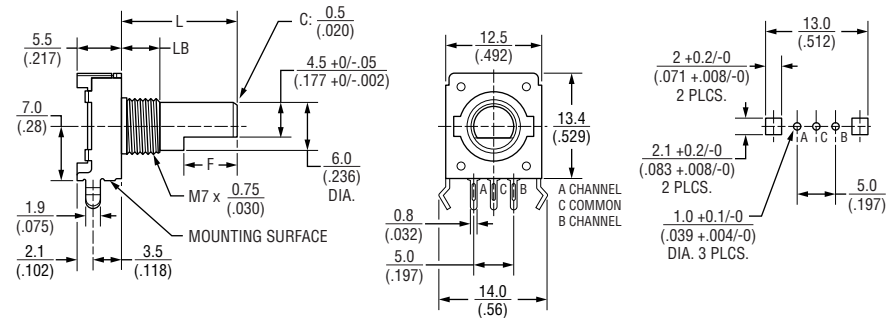

PEC11R-1xxxF-Sxxxx

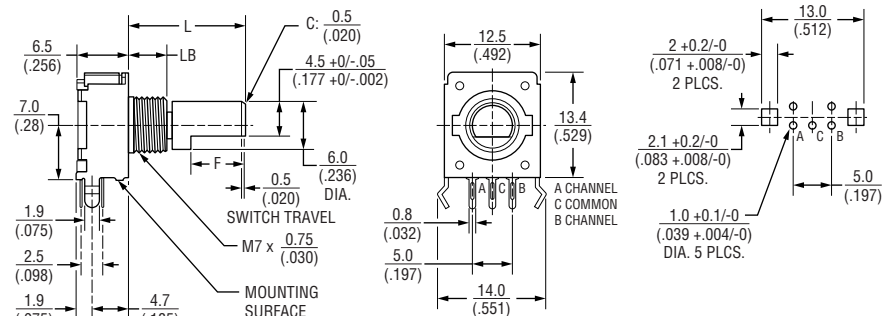

PEC11R-2xxxF-Nxxxx

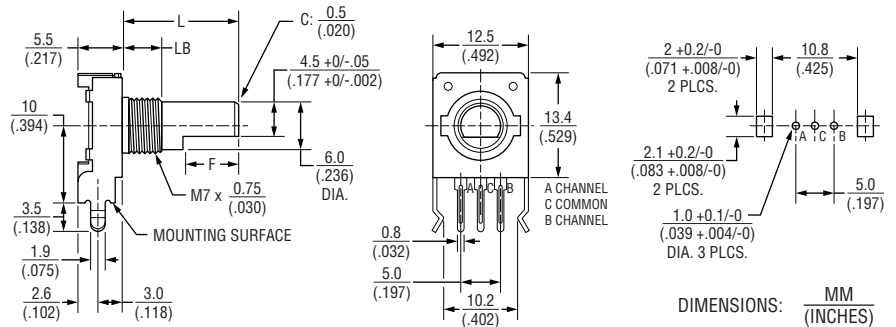

DIMENSIONS: $\frac{\text{MM}}{\text{(INCHES)}}$



CAUTION

Do not store product in high temperature and humidity, direct sunlight and/or places where corrosive gases may be generated. Please use product within 6 months from the date of delivery and promptly after unpacking.

Applications

Level control, tuning and timer settings in:

- Audio-visual equipment
- Consumer electric appliances
- Radios
- Musical instrumentation
- Communications equipment

PEC11R Series - 12 mm Incremental Encoder **BOURNS®**

Product Dimensions (continued)

PEC11R-2xxxF-Sxxxx

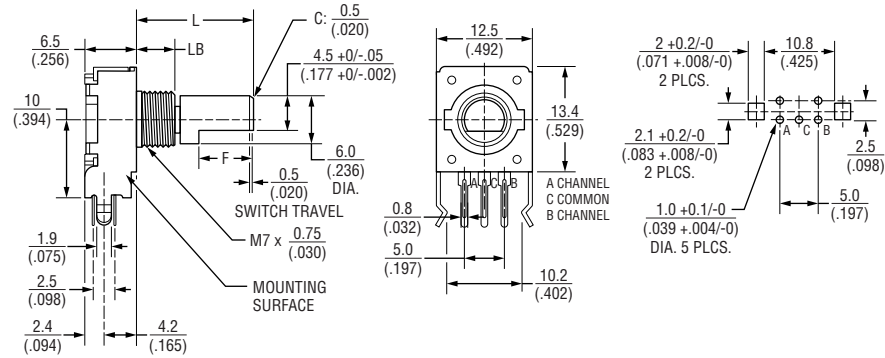

DIMENSIONS: $\frac{\text{MM}}{\text{(INCHES)}}$

PEC11R-4xxxF-Nxxxx

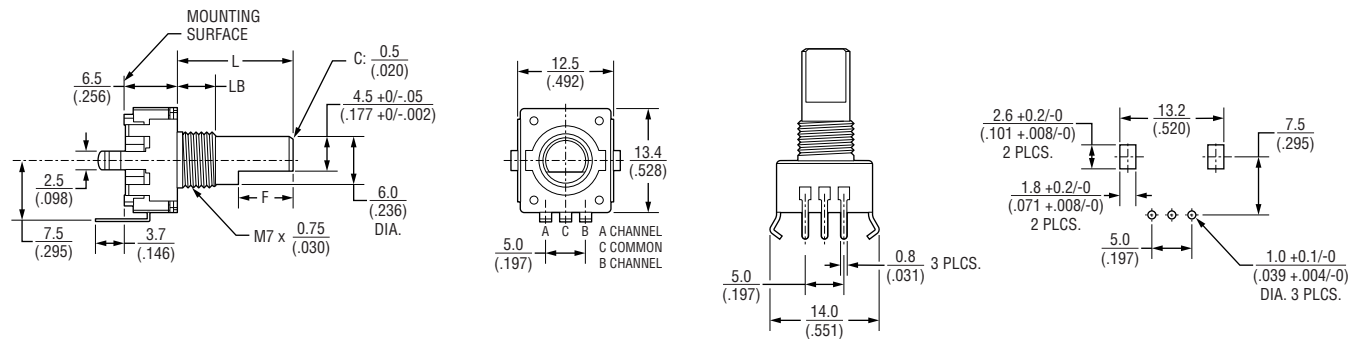

PEC11R-4xxxF-Sxxxx

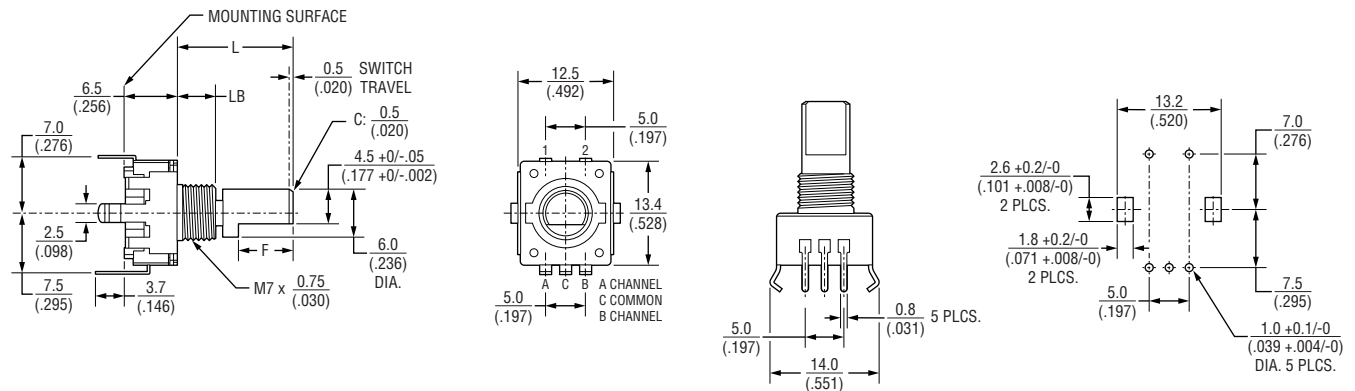

Specifications are subject to change without notice.

Users should verify actual device performance in their specific applications.

The products described herein and this document are subject to specific legal disclaimers as set forth on the last page of this document, and at www.bourns.com/docs/legal/disclaimer.pdf.

PEC11R Series - 12 mm Incremental Encoder



Shaft Dimensions

Flatted Shaft

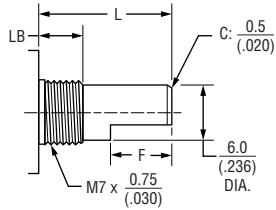

L	LB	F
$\frac{15}{(.591)}$	$\frac{5}{(.197)}$	$\frac{7}{(.276)}$
$\frac{20}{(.787)}$	$\frac{7}{(.276)}$	$\frac{10}{(.394)}$
$\frac{25}{(.984)}$	$\frac{7}{(.276)}$	$\frac{12}{(.472)}$
$\frac{30}{(1.181)}$	$\frac{7}{(.276)}$	$\frac{12}{(.472)}$

DIMENSIONS: $\frac{\text{MM}}{\text{(INCHES)}}$

Knurled Shaft

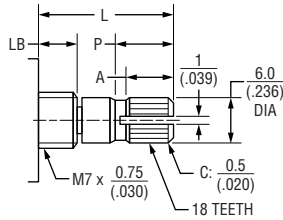

Knurled Shaft Without Switch

L	LB	P	A
$\frac{15}{(.591)}$	$\frac{5}{(.197)}$	$\frac{8}{(.315)}$	$\frac{6}{(.236)}$
$\frac{20}{(.787)}$	$\frac{7}{(.276)}$	$\frac{7}{(.276)}$	$\frac{6}{(.236)}$
$\frac{25}{(.984)}$	$\frac{7}{(.276)}$	$\frac{12}{(.472)}$	$\frac{10}{(.394)}$
$\frac{30}{(1.181)}$	$\frac{7}{(.276)}$	$\frac{16}{(.630)}$	$\frac{12}{(.472)}$

Knurled Shaft With Switch

L	LB	P	A
$\frac{15}{(.591)}$	$\frac{5}{(.197)}$	$\frac{7}{(.276)}$	$\frac{6}{(.236)}$
$\frac{20}{(.787)}$	$\frac{7}{(.276)}$	$\frac{7}{(.276)}$	$\frac{6}{(.236)}$
$\frac{25}{(.984)}$	$\frac{7}{(.276)}$	$\frac{12}{(.472)}$	$\frac{10}{(.394)}$
$\frac{30}{(1.181)}$	$\frac{7}{(.276)}$	$\frac{16}{(.630)}$	$\frac{12}{(.472)}$

Hardware

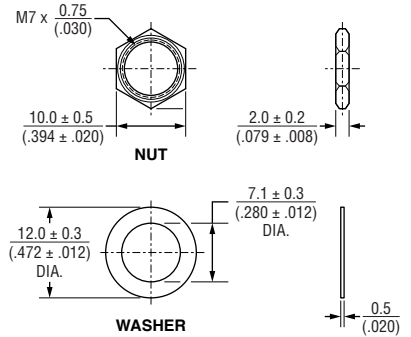

Quadrature Output Table

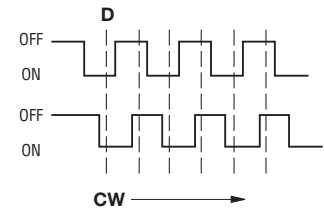

Suggested Filter Circuit

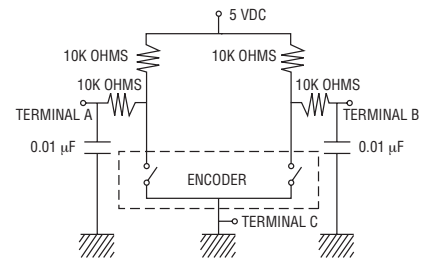

Switch Circuit



How To Order

PEC11R 4 0 20 F - S 0012

Model _____

Terminal Configuration _____
 1 = PC Pin Vertical / Side Facing 7 mm 4 = PC Pin Horizontal / Rear Facing
 2 = PC Pin Vertical / Side Facing 10 mm

Detent Option _____
 0 = No Detents (12, 18, 24 pulses) 2 = 24 Detents (12, 24 pulses)
 1 = 18 Detents (18 pulses) 3 = 12 Detents (12, 24 pulses)

Standard Shaft Length _____
 15 = 15.0 mm 25 = 25.0 mm
 20 = 20.0 mm 30 = 30.0 mm

Shaft Style _____
 F = Metal Flatted Shaft K = Metal Knurled Shaft¹

Switch Configuration _____
 S = Push Momentary Switch N = No Switch

Resolution _____
 0012 = 12 Pulses per 360 ° Rotation 0024 = 24 Pulses per 360 ° Rotation
 0018 = 18 Pulses per 360 ° Rotation

¹Metal knurled shaft without switch is available in 15, 20 and 30 mm shaft lengths.
 Metal knurled shaft with push momentary switch is available in 15 and 20 mm shaft lengths.

REV. 09/23

Specifications are subject to change without notice. Users should verify actual device performance in their specific applications.

The products described herein and this document are subject to specific legal disclaimers as set forth on the last page of this document, and at www.bourns.com/docs/legal/disclaimer.pdf.