

Radar Pulsed Power Transistor 20W, 3.1-3.5 GHz, 100µs Pulse, 10% Duty

Rev. V1

Features

- NPN silicon microwave power transistors
- Common base configuration
- Broadband Class C operation
- High efficiency inter-digitized geometry
- Diffused emitter ballasting resistors
- Gold metallization system
- Internal input and output impedance matching
- Hermetic metal/ceramic package
- RoHS compliant

Outline Drawing

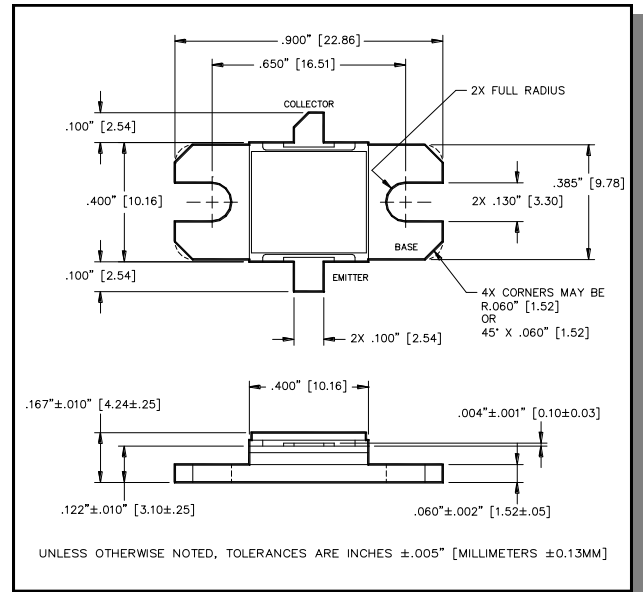

Absolute Maximum Ratings at 25°C

Parameter	Symbol	Rating	Units
Collector-Emitter Voltage	V_{CES}	65	V
Emitter-Base Voltage	V_{EBO}	3.0	V
Collector Current (Peak)	I_C	2.4	A
Power Dissipation @ +25°C	P_{TOT}	200	W
Storage Temperature	T_{STG}	-65 to +200	°C
Junction Temperature	T_J	200	°C

Electrical Specifications: $T_C = 25 \pm 5^\circ\text{C}$ (Room Ambient)

Parameter	Test Conditions	Frequency	Symbol	Min	Max	Units
Collector-Emitter Breakdown Voltage	$I_C = 10\text{mA}$		BV_{CES}	65	-	V
Collector-Emitter Leakage Current	$V_{CE} = 40\text{V}$		I_{CES}	-	1.5	mA
Thermal Resistance	$V_{CC} = 36\text{V}$, $P_{out} = 20\text{W}$	$F = 3.1, 3.3, 3.5\text{ GHz}$	$R_{TH(JC)}$	-	1.1	°C/W
Output Power	$V_{CC} = 36\text{V}$, $P_{out} = 20\text{W}$	$F = 3.1, 3.3, 3.5\text{ GHz}$	P_{IN}	-	3.6	W
Power Gain	$V_{CC} = 36\text{V}$, $P_{out} = 20\text{W}$	$F = 3.1, 3.3, 3.5\text{ GHz}$	G_P	7.5	-	dB
Collector Efficiency	$V_{CC} = 36\text{V}$, $P_{out} = 20\text{W}$	$F = 3.1, 3.3, 3.5\text{ GHz}$	η_C	35	-	%
Input Return Loss	$V_{CC} = 36\text{V}$, $P_{out} = 20\text{W}$	$F = 3.1, 3.3, 3.5\text{ GHz}$	RL	-	-6	dB
Load Mismatch Tolerance	$V_{CC} = 36\text{V}$, $P_{out} = 20\text{W}$	$F = 3.1, 3.3, 3.5\text{ GHz}$	VSWR-T	-	2:1	-

Typical RF Performance

Freq. (GHz)	Pin (W)	Pout (W)	Gain (dB)	Ic (A)	Eff (%)	RL (dB)	VSWR-T (2:1)
3.1	2.4	20	9.19	1.29	43.1	-10.2	P
3.3	2.7	20	8.65	1.28	43.4	-10.9	P
3.5	3.0	20	8.30	1.28	43.4	-13.0	P

Gain vs. Frequency

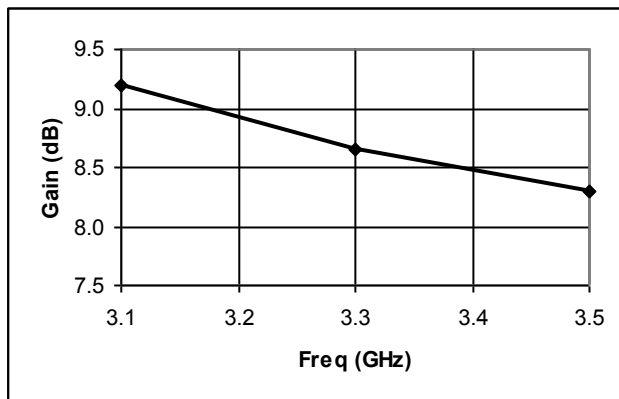

Collector Efficiency vs. Frequency

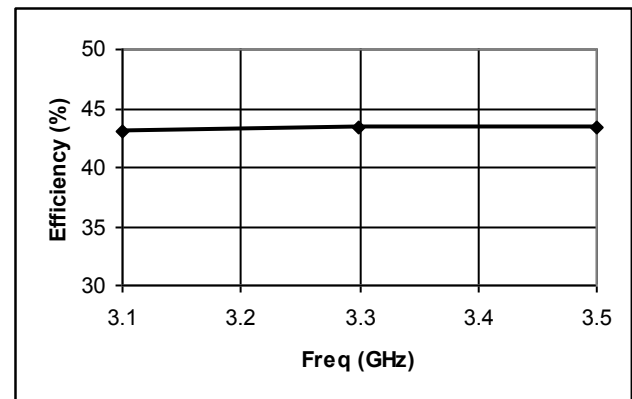

RF Test Fixture Impedance

F (GHz)	Z _{IF} (Ω)	Z _{OF} (Ω)
3.1	16.0 + j5.5	19.0 + j3.4
3.3	14.5 + j1.6	14.2 - j2.8
3.5	11.3 + j0.0	10.7 - j3.3

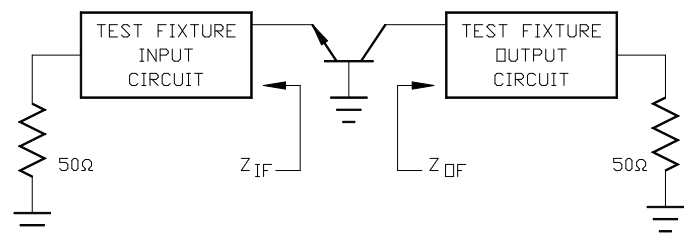

Test Fixture Circuit Dimensions

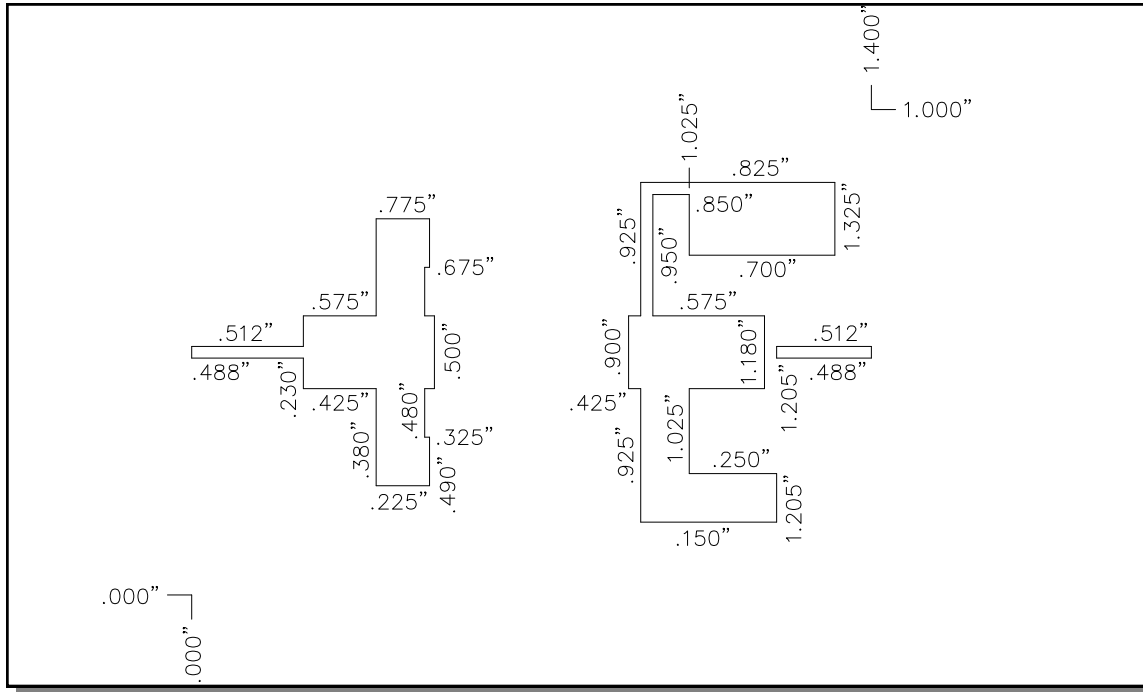

Test Fixture Assembly

